

REVISIONS							
ZONE	SYM	DESCRIPTION	DATE	E.M.N. NO.	DRAFT	CHKD	APPD
	X1	ADD 6" HOLES & DETAIL "E"	1/4/64	X1	TJC		TJC
F5	X2	1 1/16 WAS 2 1/16 (ERROR)	1/5/64	X2	JLR		TJC
	O	ORIGINAL RELEASE FOR PRODUCTION	4-20-64	O	VAM	@	

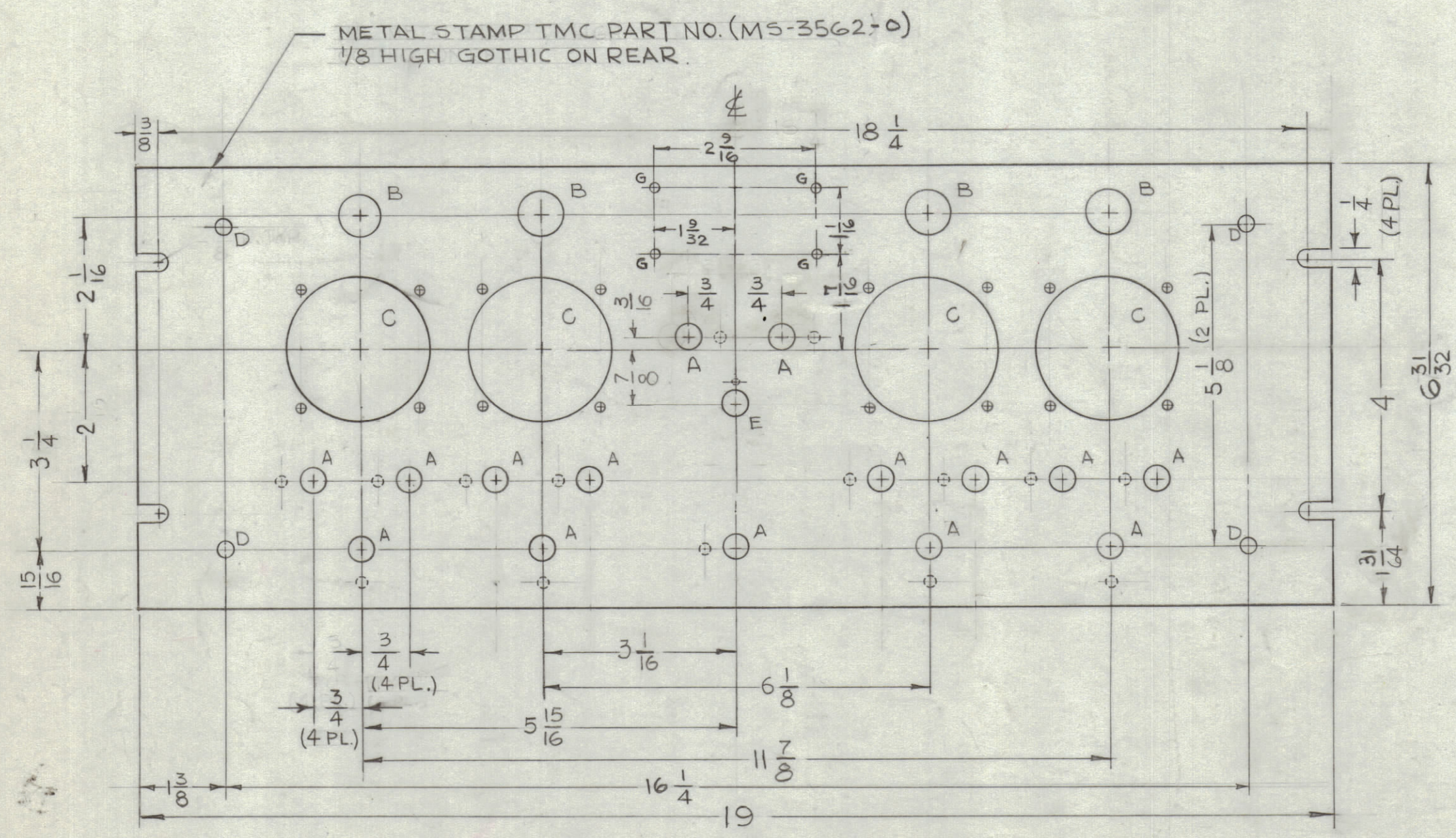

HOLE	DESCRIPTION	REQ.
A	SEE DETAIL	15
B	11/16 DIA.	4
C	SEE DETAIL	4
D	13/64 DIA. FOR #10-32	4
E	SEE DETAIL	1
G	.076 DIA.	4

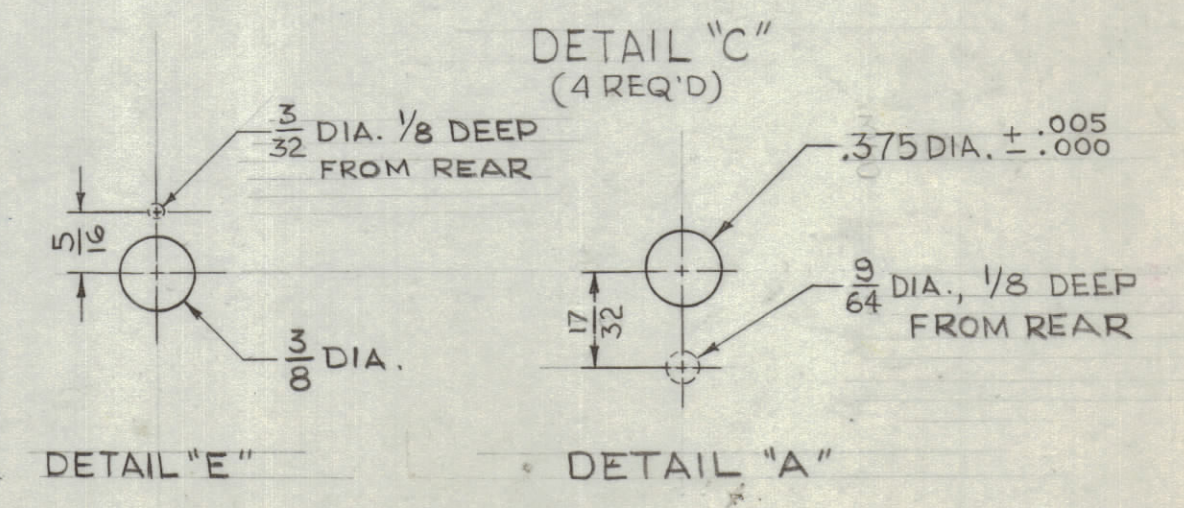
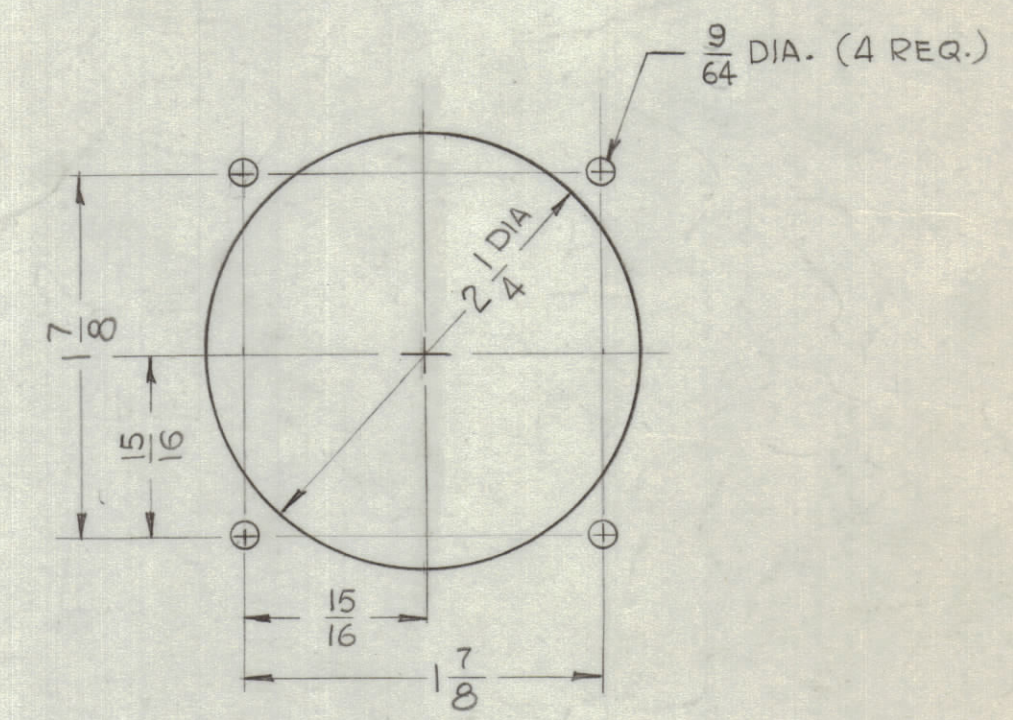

MACHINING:

1. MILL ALL EDGES.
2. HOLES MUST BE DRILLED, UNLESS OTHERWISE SPECIFIED.
3. LATERAL BOW OF PANEL MUST BE KEPT TO .031 TOLERANCE.
4. PANEL MUST BE FREE OF ALL MACHINING MARKS, GOUGES AND SCRATCHES. IF NECESSARY, SAND FRONT OF PANEL WITH NO. 120 GRIT SANDPAPER.

FINISH NOTES:

1. S404 - IRIDITE 14-2 AL-COAT.
2. S114 - ZINC CHROMATE PRIMER) FRONT AND
3. S115 - SMOOTH GRAY ENAMEL) EDGES ONLY

NOTES

REF: LD-1401		LIST OF MATERIAL	
REQ'D	ITEM	PART NUMBER	DESCRIPTION
	T. AALTONEN		
MATERIAL		THE TECHNICAL MATERIEL CORP.	
3/16 THK ALUMINUM-2024-T4		MAMARONECK, NEW YORK	
FINISH		TITLE	
SEE NOTE		FRONT, PANEL	
UNLESS OTHERWISE SPECIFIED DIMENSIONS ARE IN INCHES AND INCLUDE CHEMICALLY APPLIED OR PLATED FINISHES		DRAWN	DATE
		G.D.L.	6-26-63
		CHECKED	DATE
		@	3-11-64
DECIMALS		ELECT. DES.	DATE
.X ± .05		TJC	
.XX ± .01		MECH. DES.	DATE
.XXX ± .005		JLR	
TOLERANCES		SHEET	
FRACTIONS ± 1/64 ANGLES ± 0° 30'		MS-3562	
		O	
		REV. LTR.	

Q'TY./UNIT	MODEL USED ON	ASS'Y. NO.
1	MSA-J	A-3403
SCALE	CODE	
1:2	A	
THE CONTENTS OF THIS DRAWING ARE THE EXCLUSIVE PROPERTY OF THE TECHNICAL MATERIEL CORP. ITS UNAUTHORIZED USE OR REPRODUCTION IN WHOLE OR IN PART IS STRICTLY FORBIDDEN.		

MS-3562