

MS-3533 0

REVISIONS

SYM	DESCRIPTION	DATE	E.M.N. NO.	DRAFT	CHKD	APPD
0	ORIGINAL RELEASE FOR PRODUCTION	5-27-64	0	A.M.		

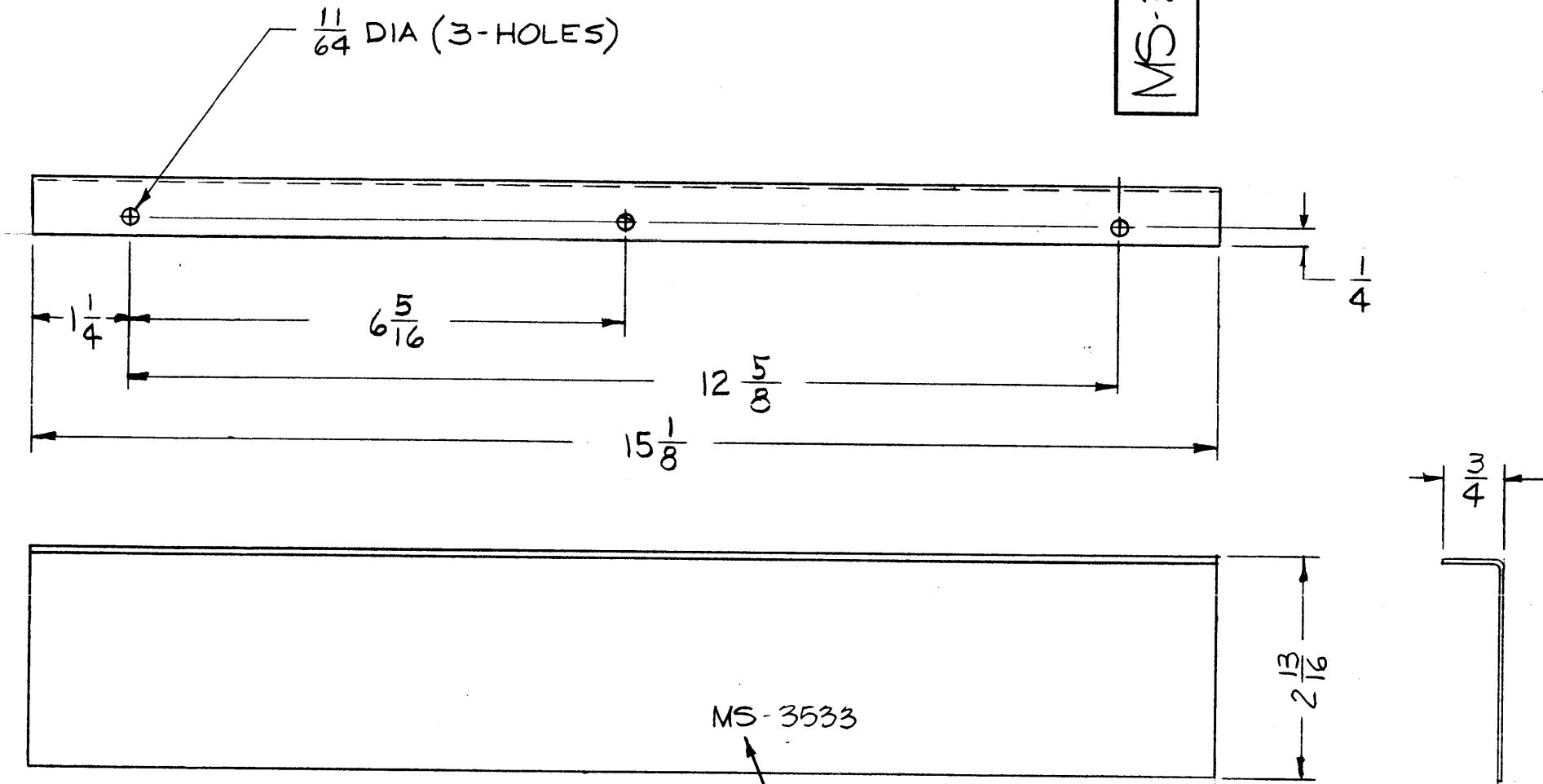

UNLESS OTHERWISE SPECIFIED:

1. USE MATERIAL THICKNESS FOR MAXIMUM RADIUS ON ALL BENDS.
2. ALL ANGULAR BENDS 90°.
3. REMOVE ALL BURRS AND SHARP EDGES.
4. MOUNT INSERTS AFTER FINISHING.

METAL STAMP TMC PART NO. 1/8 HIGH GOTHIC. WITH LATEST REVISION LETTER

2	GPT 200K	AX-395
Q'TY./UNIT	MODEL USED ON	ASS'Y. NO.
SCALE	CODE	
1=2		
THE CONTENTS OF THIS DRAWING ARE THE EXCLUSIVE PROPERTY OF THE TECHNICAL MATERIEL CORP. ITS UNAUTHORIZED USE OR REPRODUCTION IN WHOLE OR IN PART IS STRICTLY FORBIDDEN.		

REQ'D.	ITEM	PART NUMBER	DESCRIPTION	SYMBOL
LIST OF MATERIAL				
MATERIAL .064 THICK ALUMINUM 5052-H32			THE TECHNICAL MATERIEL CORP. MAMARONECK, NEW YORK	
FINISH S404- IRIDITE 14-2 AL COAT			TITLE SHIELD, SIDE WINDOW	
UNLESS OTHERWISE SPECIFIED DIMENSIONS ARE IN INCHES AND INCLUDE CHEMICALLY APPLIED OR PLATED FINISHES			DRAWN A. TURSI	DATE 10-7-64
			CHECKED AA	DATE
DECIMALS .X ± .05 .XX ± .01 .XXX ± .005			ELECTR. DES. hca	DATE 9/18/64
TOLERANCES			MECH. DES. 2/3/64	DATE
FRACTI NS ± 1/64 ANGLES ± 0° 30'			FINAL APPROVAL RAC	DATE
			MS-3533	0
			SHEET	REV. LTR.

NOTES