

HOLE	DESCRIPTION	REQ,D
A	11/64 DIA.	3
B	.250-.253 DIA.	6
C	SEE DETAIL "C"	2
D	9/64 DIA.	4

REVISIONS						
ZONE	SYM	DESCRIPTION	DATE	E.M.N. NO.	DRAFT	CHKD
	Ø	ORIGINAL RELEASE	11/23/65	Ø		JLO

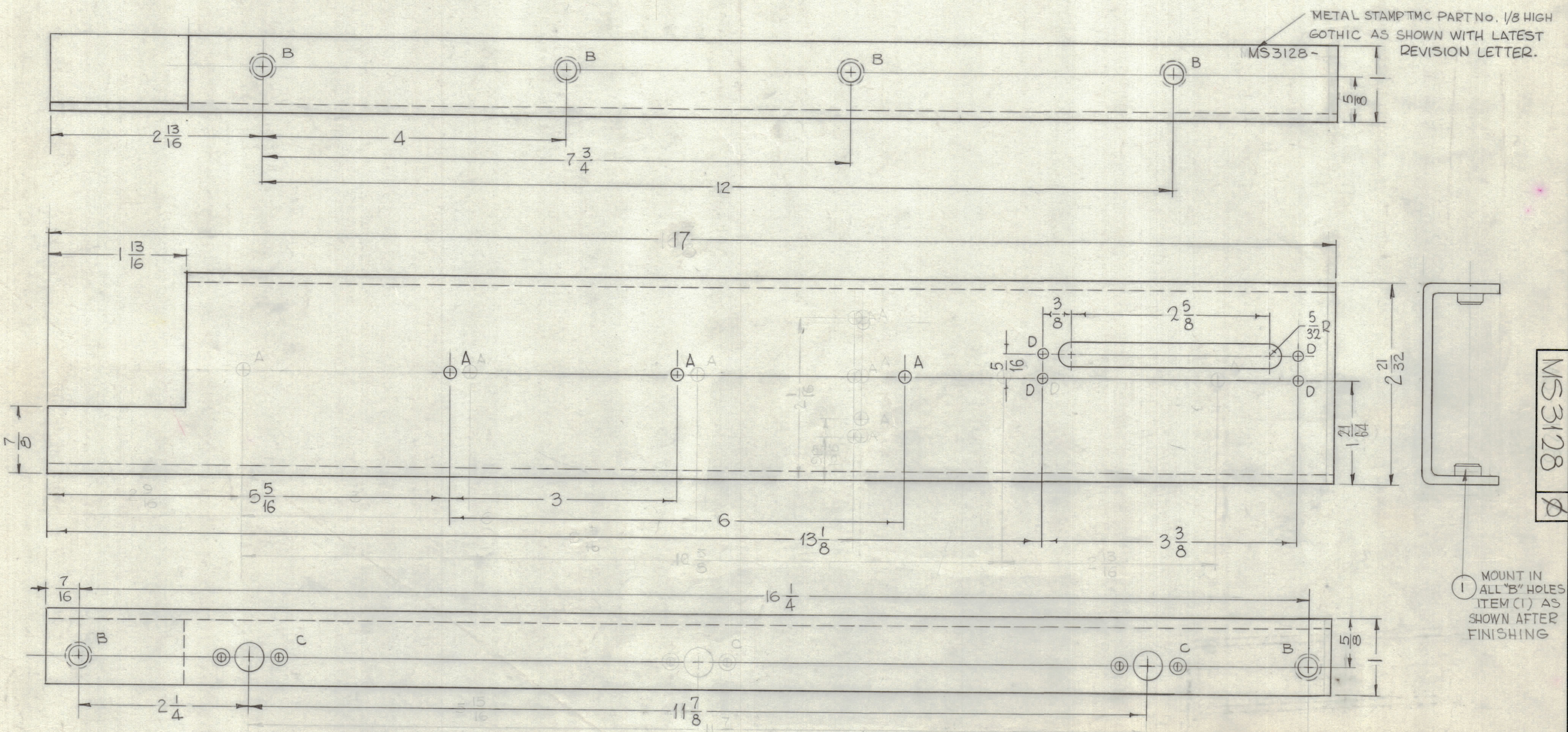
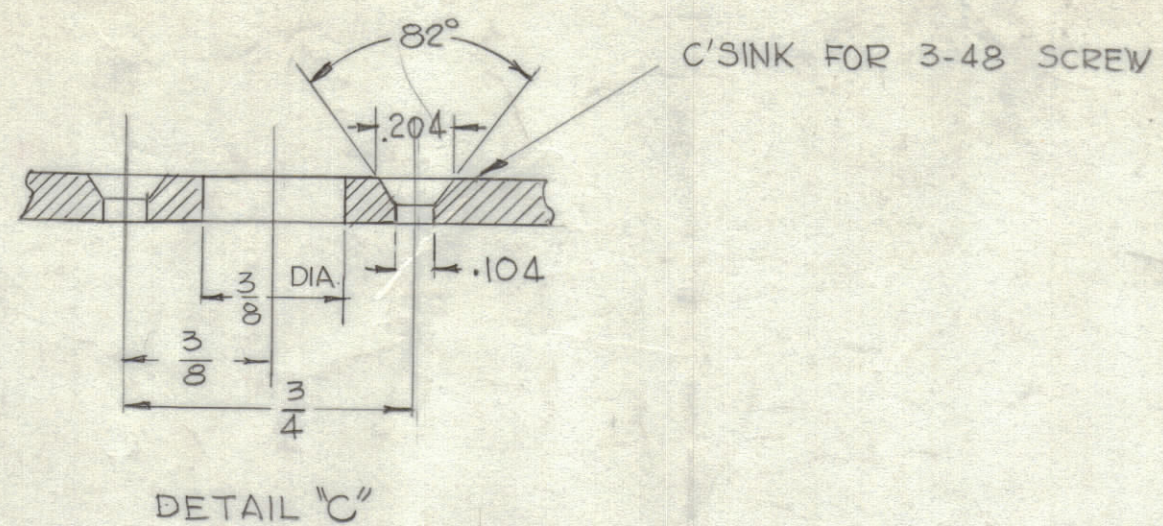

- UNLESS OTHERWISE SPECIFIED -
 ALL ANGULAR BENDS 90°
 USE MATERIAL THICKNESS FOR MAX. RADIUS ON ALL BENDS.
 MOUNT INSERTS AFTER FINISHING

REF-TMC DWG. NO. LD1713

REQ'D.	ITEM	PART NUMBER	DESCRIPTION	SYMBOL
6	1	NT-129-1032-6	NUT, ROUND, SWAGE TYPE	B
0. POSE LIST OF MATERIAL				
MATERIAL			THE TECHNICAL MATERIEL CORP.	
1/8 THK ALUMINUM			MAMARONECK, NEW YORK	
5052-H32			TITLE	
S404 YEL. IRIDITE			DIVIDER, CHASSIS, RIGHT SIDE	
			IPA DRIVER DRAWER	
FINISH		DRAWN		
		G.D.L.		
		DATE		
		3-30-63		
		CHECKED		
		JCB		
		DATE		
		11/23/65		
		ELECT. DES.		
		DATE		
		MECH. DES.		
		DATE		
		MS3128 Ø		
		SHEET		
		REV. LTR.		

QTY./UNIT	MODEL USED ON	ASS'Y. NO.
SCALE	CODE	
FULL	A	

THE CONTENTS OF THIS DRAWING ARE THE EXCLUSIVE PROPERTY OF THE TECHNICAL MATERIEL CORP. ITS UNAUTHORIZED USE OR REPRODUCTION IN WHOLE OR IN PART IS STRICTLY FORBIDDEN.

NOTES