

IF IT IS FOUND DESIRABLE TO CHANGE ANY TOLERANCE OR OTHER DETAIL SPECIFIED ON THIS DRAWING NOTIFY THE PURCHASER PROMPTLY.

MAXIMUM ALLOWABLE TOLERANCES HAVE BEEN DETERMINED AND DEVIATIONS WILL BE CAUSE FOR REJECTION. REMOVE ALL BURRS AND SHARP EDGES

MS-324 C

A - $\frac{9}{64}$ (.140) D. 2 HOLES REQ.
 B - $\frac{7}{32}$ (.218) D. 2 " " "
 C - DRILL & TAP A-40 3 " " "
 D - $\frac{9}{64}$ X $\frac{9}{32}$ SLOT 3 SLOTS " "

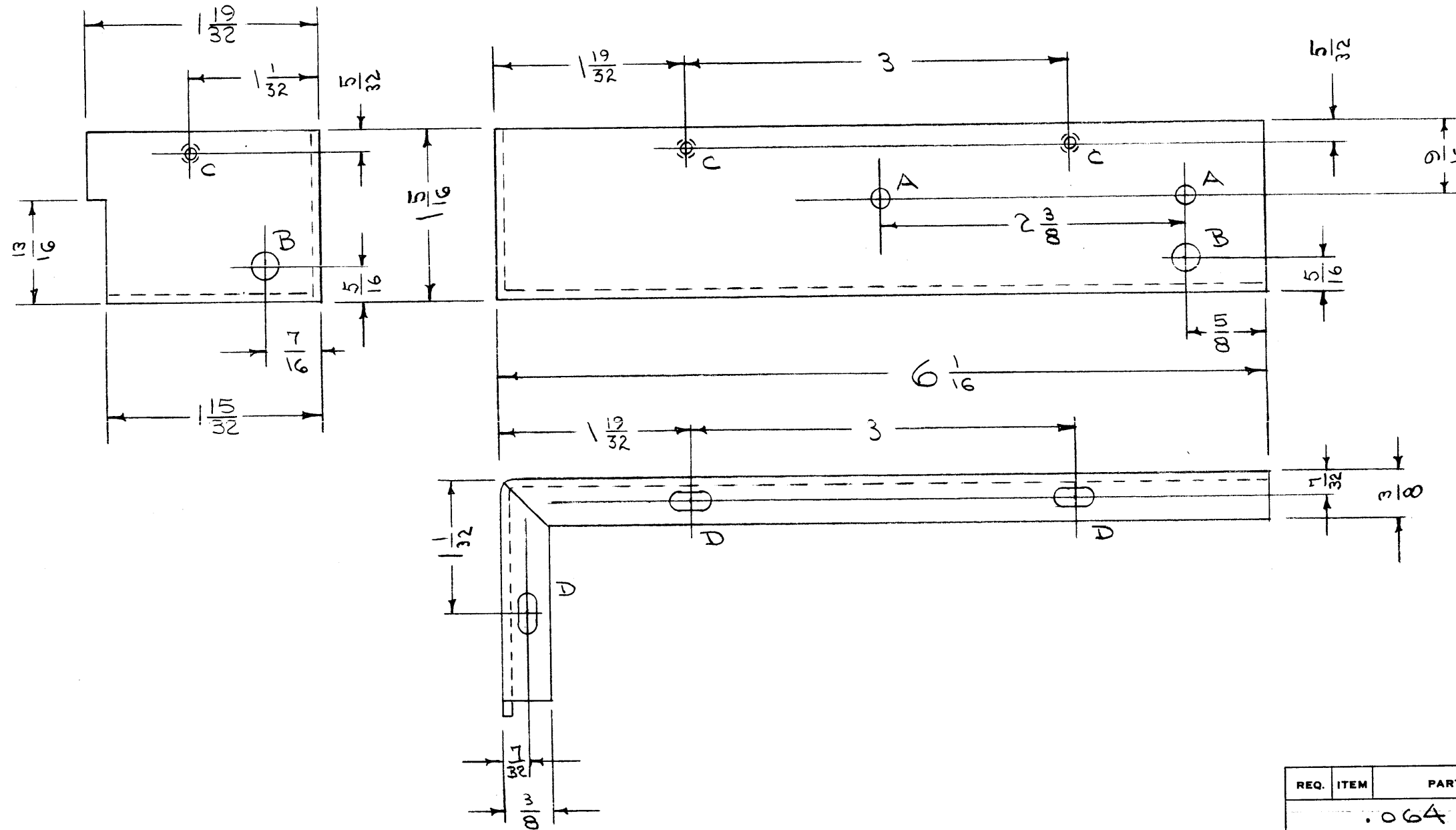

PROPERTY OF THE TECHNICAL MATERIEL CORPORATION
 THE TECHNICAL MATERIEL CORPORATION claims proprietary right in the material disclosed herein. This drawing is issued in confidence for engineering information only and may not be reproduced or used to manufacture anything shown hereon without permission from THE TECHNICAL MATERIEL CORPORATION to the user. This drawing is loaned for mutual assistance and is subject to recall at any time.

Property of:
 THE TECHNICAL MATERIEL CORPORATION
 MAMARONECK, NEW YORK

ISSUE	ITEM	CHANGED FROM	DATE	CN. NO.	DRAFTS	CHECKER	ENG. APP.
C	2	1-15/32 DIM. WAS 1-11/16	2-8-62	632B	E _A	<i>[Signature]</i>	<i>[Signature]</i>
	1	1-19/32 DIM. WAS 1-13/16					
B	1	S-404 WAS S-101	12/11/59	1001	AB	<i>[Signature]</i>	EMN
A	1	COMPLETE REVISION	1/20/55	1	ESB	<i>[Signature]</i>	<i>[Signature]</i>

TOLERANCES	SCALE: Do Not Scale
ALL OTHERS	DRILL, PUNCH, COMMERCIAL STOCK SIZES AND MANUFACTURERS TOLERANCES ARE NOT INCLUDED.
DEC. DIM. ±	
FRAC. DIM. ±	
ANGULAR DIM. ±	

1	VOX			1-20-55
1	VOX = 1/2	291		1-20-55
REQ. PER UNIT	MODEL	PROJECT NO.	ASS'Y. NO.	DATE

REQ.	ITEM	PART NO.	DESCRIPTION	SYMBOL
		.064	THE TECHNICAL MATERIEL CORP.	
		STOCK SIZE	MAMARONECK, NEW YORK	
	ALUMINUM	#	SHIELD, 1FO	
	MATERIAL	WEIGHT PER PC.	R.F. CHASSIS	
	52S H32			
	TYPE & TEMPER		C.D.D. 1-20-55	<i>[Signature]</i>
			DRAWN	ELEC. DES. APP.
				MECH. DES. APP.
			CHECKED	FINAL APPROVAL
			S-404 YELLOW IRIDITE	
			FINISH & SPEC. NO.	

MS-324 C