

MS-2684 - C

METAL STAMP TMC PART NO. 1/8 HIGH GOTHIC AS SHOWN.

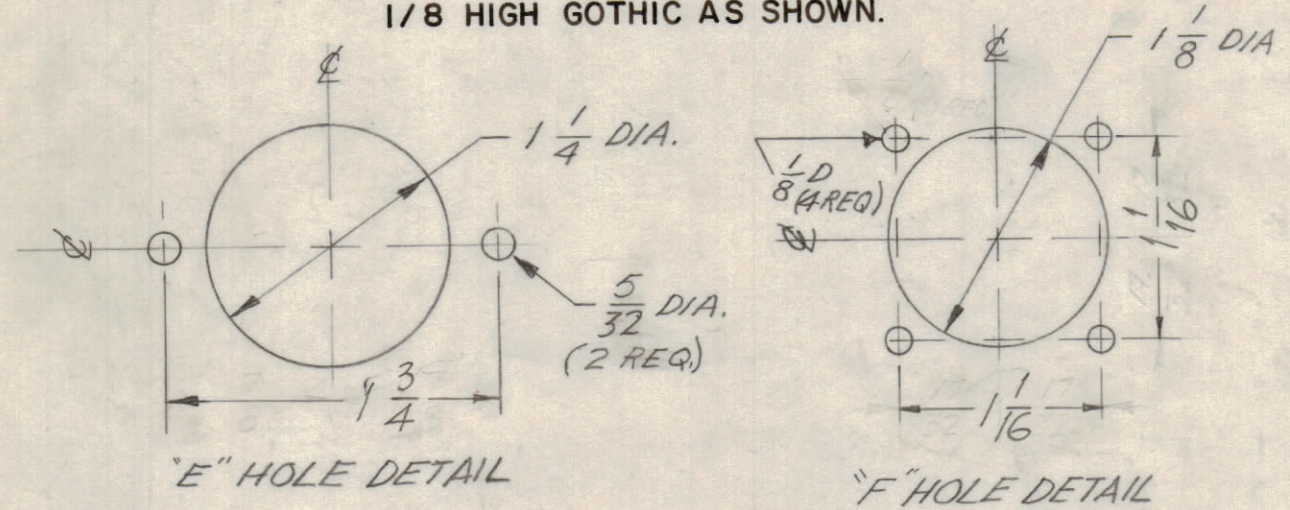

- HOLES:
- A - 11/64 DIA.
  - C - 3/8 DIA.
  - D - SEE DETAIL
  - E - (SEE DETAIL)
  - F - (SEE DETAIL)
  - G - (SEE DETAIL)
  - H - 1/4 DIA.
  - J - 5/32 DIA.

- 12 REQ.
- 1 REQ.
- 2 REQ.
- 1 REQ.
- 3 REQ.
- 3 REQ.
- 1 REQ.
- 2 REQ.

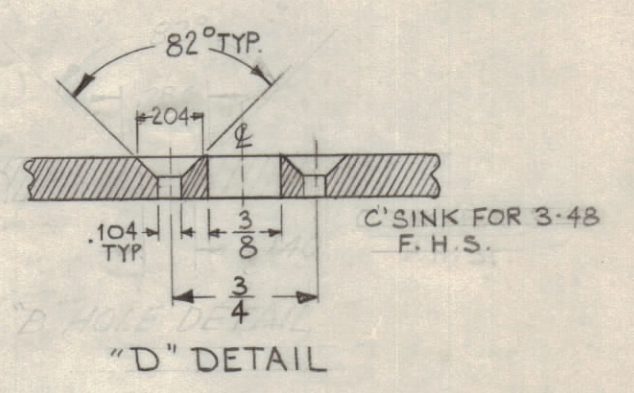
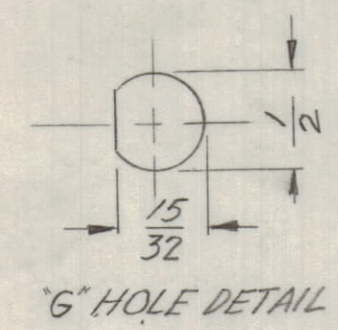

USE MATERIAL THICKNESS FOR MAX. RADIUS ON ALL BENDS UNLESS OTHERWISE SPECIFIED  
REF: LD-986

UNLESS OTHERWISE SPECIFIED DIMENSIONS ARE IN INCHES AND INCLUDE CHEMICALLY APPLIED OR PLATED FINISHES

DECIMALS: .x ± .05, .xx ± .01, .xxx ± .005

FRACTIONS: ± 1/64, ± 1/80, ANGLES ± 0° 30'

TOLERANCES

COP. H. H. H. GUARANTEED 2-68

D	E4F4	ADDED 2 "J" HOLES	2-26-64	10967	A.M.		
C	E7	Dim. 1-3/4, 2-1/8, 4-7/16 DELETED, Dim. 1-3/8, 2-1/8, 3-1/2 ADDED	12-1-61	5984	SP		
B	B, Z	Item QNT-129-0632-4, Deleted	11-15-61	5888	SG		
A	3-F	"A" HOLE ADDED	11-2-61	5796	WH		
SYM	ZONE	DESCRIPTION	DATE	CH. NO.	DRAFTS	CHECKER	ENG. APP.
UNLESS OTHERWISE SPECIFIED:			SCALE DO NOT SCALE				
DIMENSIONS ARE IN INCHES			MAXIMUM ALLOWABLE TOLERANCES HAVE BEEN DETERMINED AND ANY DEVIATIONS WILL BE CAUSE FOR REJECTION. REMOVE ALL BURRS & SHARP EDGES				
TOLERANCES ON			A				
FRACTIONS ± 1/64			DECIMALS ± .005				
			ANGLES ± 1/2°				

1	SBS-1	PWR SUPPLY	A-2209-2	10-13-61
REQ. PER UNIT	MODEL	SECTION	ASSY. NO.	DATE
USED ON				

REQ.	ITEM	PART NO.	DESCRIPTION	SYMBOL
		.064	THE TECHNICAL MATERIEL CORP.	
		STOCK SIZE	MAMARONECK, NEW YORK	
		ALUMINUM	PLATE, REAR	
		MATERIAL		
		5052-H32	WH	
		TYPE & TEMPER	DRWN	
		HEAT TREAT. SPEC.	CHECKED	
		5404 YEL IRIDITE	RK	
		FINISH & SPEC. NO.	MS-2684	
			ELEC. DES. APP.	
			MECH. DES. APP.	
			SHEET	
			OF	
			1	