

STANDARD DRAWING

REQ. PER. UNIT	USED ON			MS-2669
	MODEL	ASS'Y. NO.	DATE	
	GDP. SER			

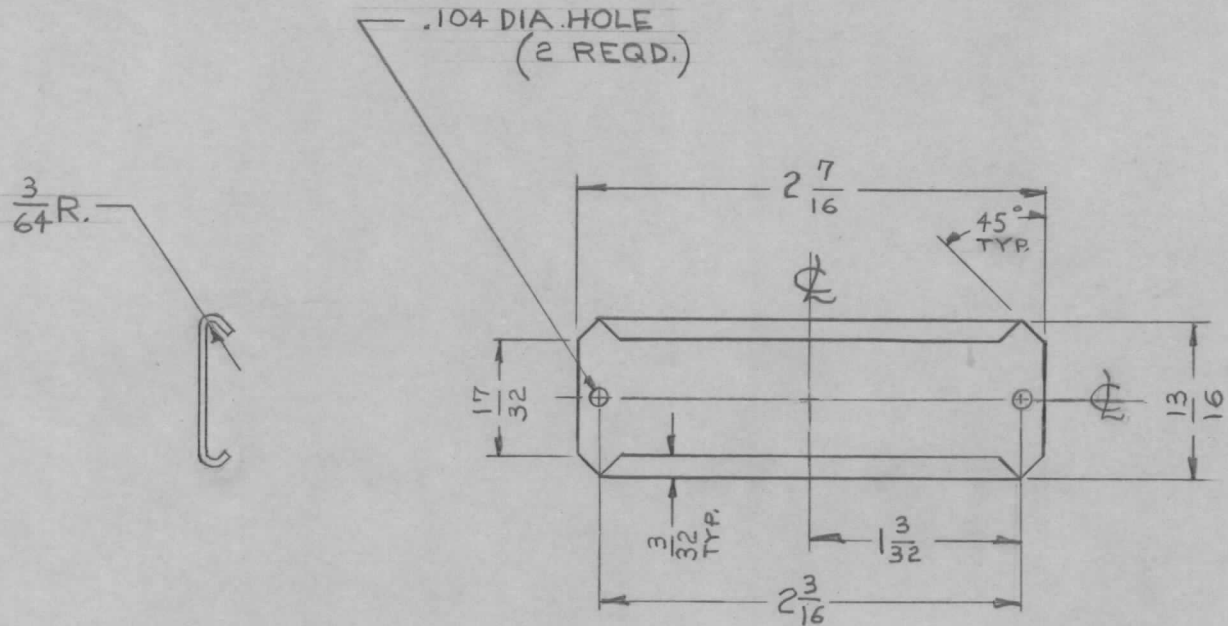

FINISH:
S-371 DEGREASE
S-114 ZINC CHROM

FINISH
S-371 DEGREASE
S-114 ZINC CHROMATE
PRIMER
S-115 SMOOTH GREY ENAMEL

UNLESS OTHERWISE SPECIFIED DIMENSIONS ARE IN INCHES AND INCLUDE CHEMICALLY APPLIED OR PLATED FINISHES		
DECIMALS	TOLERANCES	FRACTIONS
.X ± .05		± 1/64
.XX ± .01		ANGLES
.XXX ± .005		± 0° 30'

CUT HERE
GUARANTEED
2-66

								REQ. ITEM	PART NO.	DESCRIPTION		SYMBOL	
									.012	THE TECHNICAL MATERIEL CORP.			
									STOCK SIZE	MAMARONECK, NEW YORK			
									STEEL	CARD HOLDER			
								MATERIAL					
ISSUE	ITEM	CHANGED FROM	DATE	CH. NO.	DRAFTS	CHECKER	ENG. APP.	MILD		R. LOPEZ 9-22-61	<i>ALD</i>	<i>ALM</i>	
TOLERANCES			SCALE: DO NOT SCALE					TYPE & TEMPER	HEATTREAT. SPEC.	DRAWN	CHECKED	FINAL APPROVAL	
DEC. DIM. ±			MAXIMUM ALLOWABLE TOLERANCES HAVE BEEN DETERMINED AND ANY DEVIATIONS WILL BE CAUSE FOR REJECTION. REMOVE ALL BURRS AND SHARP EDGES					SEE NOTE:				MS-2669	
FRAC. DIM. ±								FINISH & SPEC. NO.		ELEC. DES. APP	MECH. DES. APP		
ANGULAR DIM. ±													