

MS-2667

| | |
|--------------|-----|
| TMC PART NO. | A |
| MS-2667-1 | 3/4 |

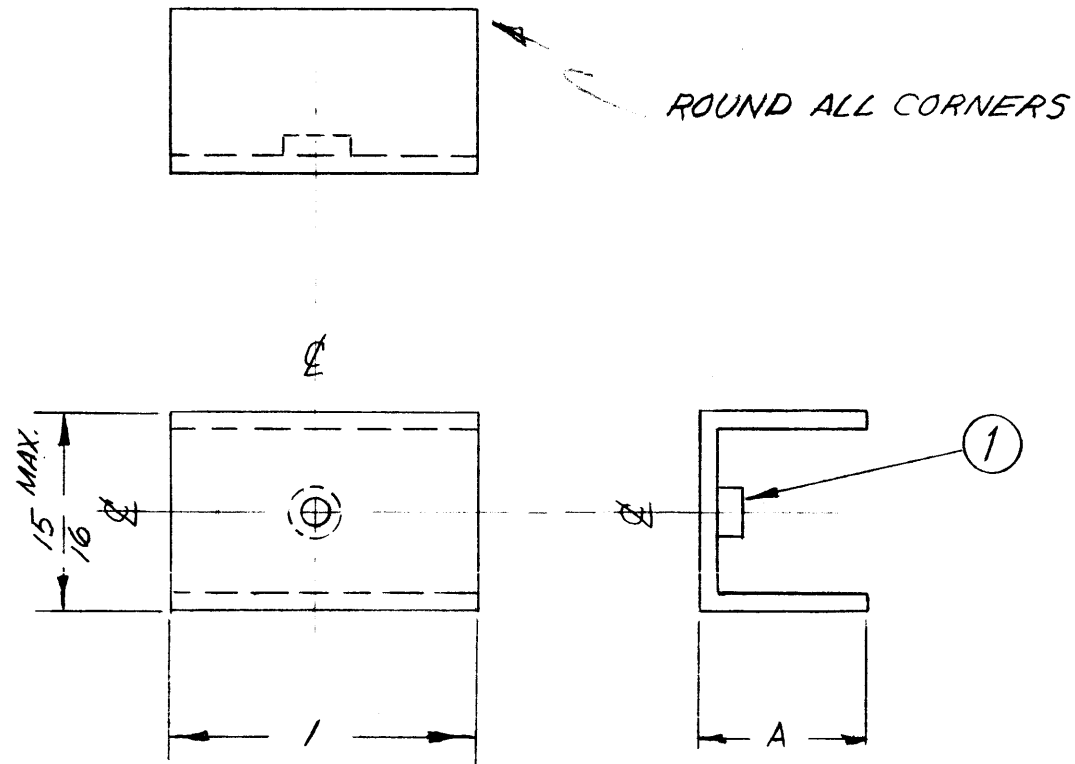

PROPERTY OF THE TECHNICAL MATERIEL CORPORATION
 THE TECHNICAL MATERIEL CORPORATION claims
 proprietary right in the material disclosed hereon.
 This drawing is issued in confidence for engineering
 information only and may not be reproduced or used
 to manufacture anything shown hereon without per-
 mission from THE TECHNICAL MATERIEL CORPORA-
 TION to the user. This drawing is loaned for mutual
 assistance and is subject to recall at any time.

Property of:
 THE TECHNICAL MATERIEL CORPORATION
 MAMARONECK, NEW YORK

| | | | | | |
|------|------|--------------------|-------------------------------|-----------------|----------------|
| 1 | 1 | NT-129-1032-4 | NUT, SWAGE TYPE | | |
| REQ. | ITEM | PART NO. | DESCRIPTION | | SYMBOL |
| | | .081 | THE TECHNICAL MATERIEL CORP. | | |
| | | STOCK SIZE | MAMARONECK, NEW YORK | | |
| | | ALUMINUM | BRACKET, NUT, CAPACITOR PLATE | | |
| | | MATERIAL | | | |
| | | 5052-H32 | wh | File | 0-3 |
| | | TYPE & TEMPER | DRAWN | CHECKER | FINAL APPROVAL |
| | | 5404-YEL. IRIDITE | | | |
| | | FINISH & SPEC. NO. | ELEC. DES. APP. | MECH. DES. APP. | |
| | | | | | MS-2667 |

| | | | | | | |
|--|-------------|---|---------|--------|---------|-----------|
| SYM | DESCRIPTION | DATE | CH. NO. | DRAFTS | CHECKER | ENG. APP. |
| UNLESS OTHERWISE SPECIFIED: | | SCALE: NOT TO SCALE | | | | |
| DIMENSIONS ARE IN INCHES | | MAXIMUM ALLOWABLE TOLERANCES HAVE BEEN DETERMINED AND ANY DEVIATIONS WILL BE CAUSE FOR REJECTION. | | | | |
| TOLERANCES ON FRACTIONS ± 1/64 DECIMALS ± .005 ANGLES ± 1/2° | | REMOVE ALL BURRS AND SHARP EDGES | | | | |

| | | | | |
|---------------|------------|---------|------------|---------|
| REQ. PER UNIT | MODEL | SECTION | ASS'Y. NO. | DATE |
| | TER-25K-50 | | | 9-21-61 |
| USED ON | | | | |