

**NOTICE TO PERSONS RECEIVING THIS DRAWING**

THE TECHNICAL MATERIEL CORPORATION claims proprietary right in the material disclosed herein. This drawing is issued in confidence for engineering information only and may not be reproduced or used to manufacture anything shown hereon without permission from THE TECHNICAL MATERIEL CORPORATION to the user. This drawing is loaned for mutual assistance and is subject to recall at any time.

Property of:  
THE TECHNICAL MATERIEL CORPORATION  
MAMARONECK, NEW YORK

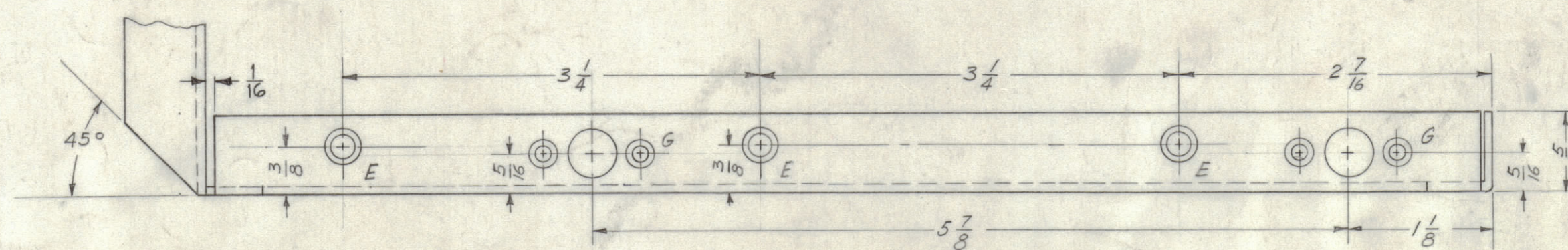
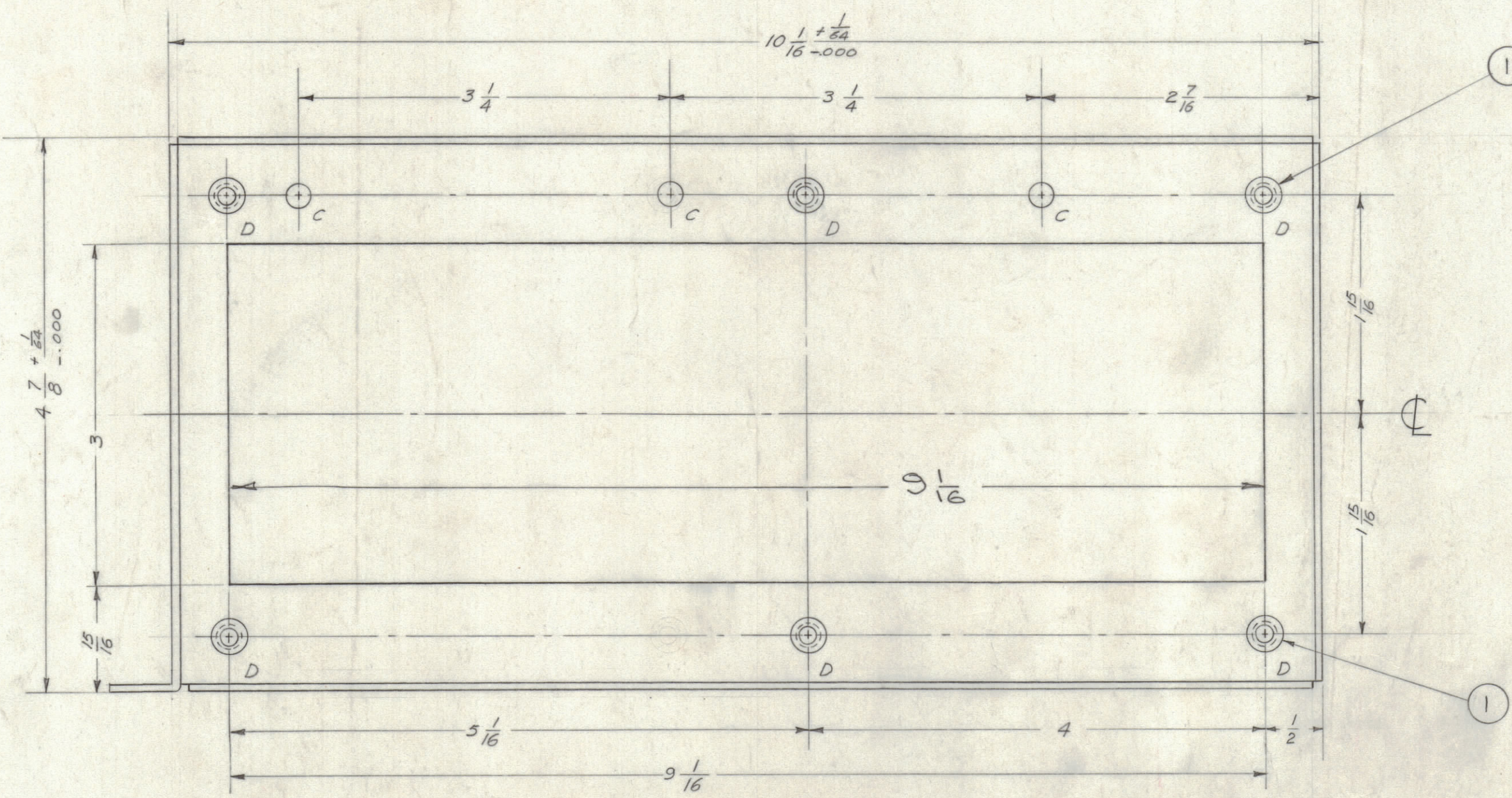
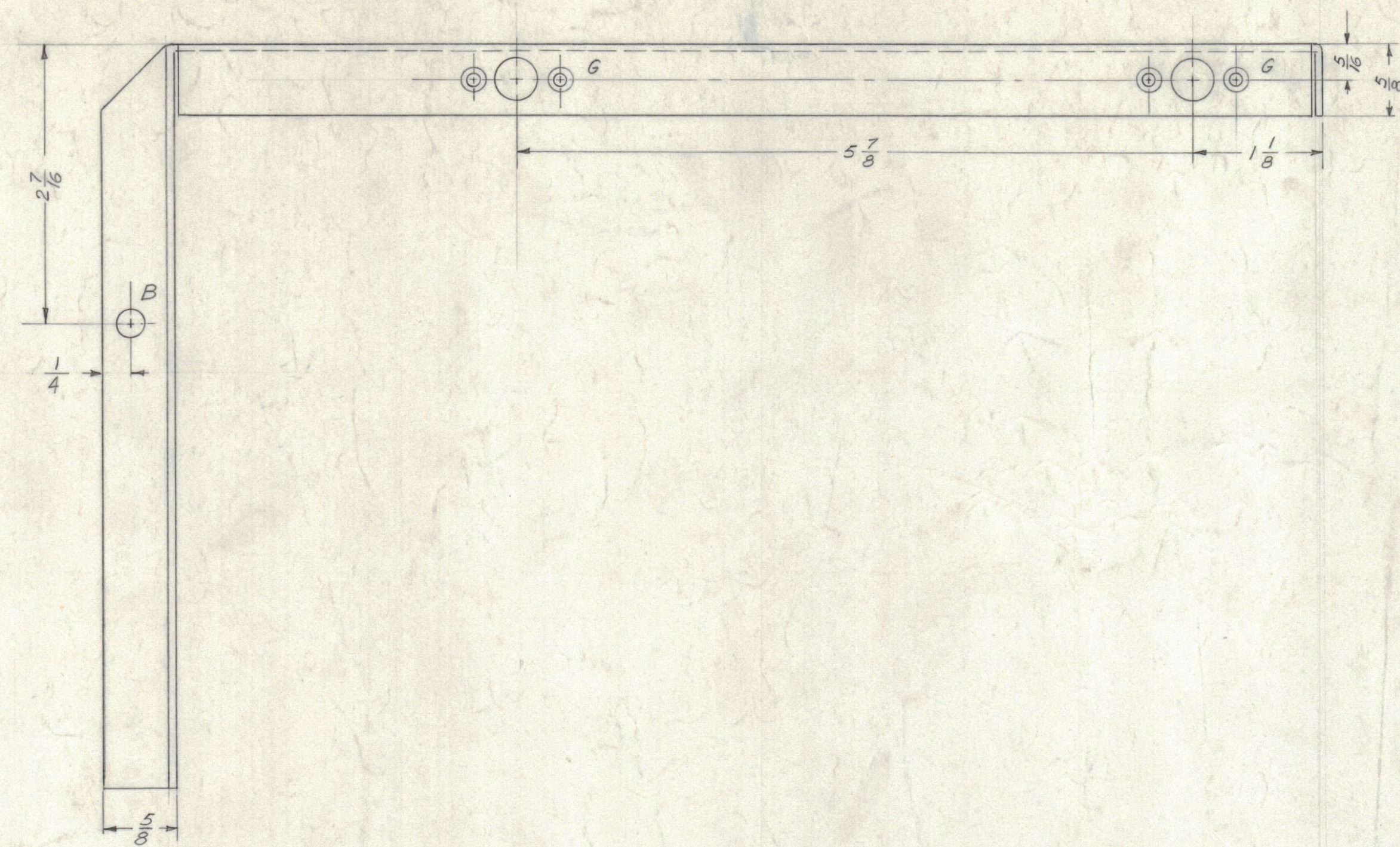

- A -  $\frac{11}{32} \times \frac{11}{64}$  SLOT 4 Req.
- B -  $\frac{1}{4}$  (.250) DIA. 1 Req.
- C -  $\frac{13}{64}$  (.203) DIA. 6 Req.
- D - #2 DRILL (.221) FOR NT-129-832-4 6 Req.

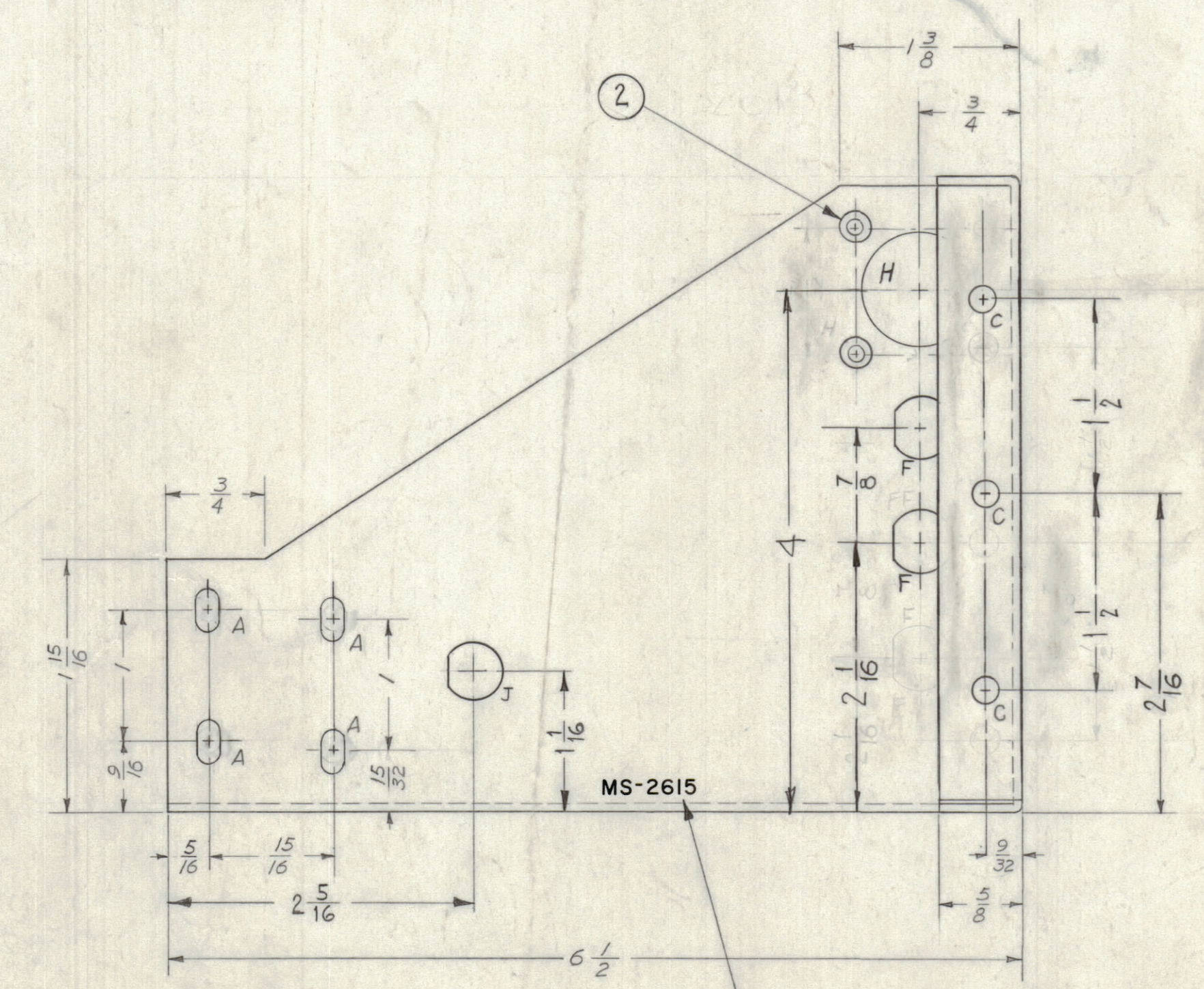
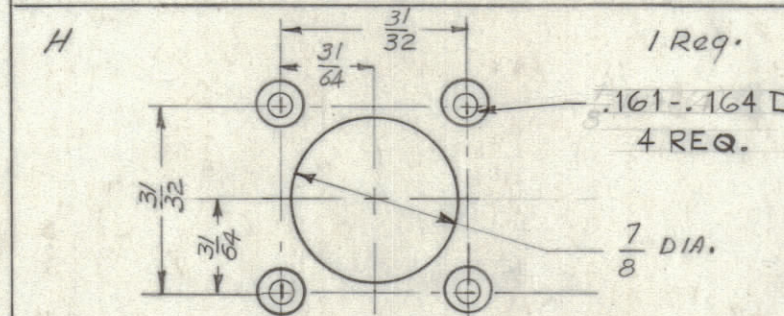
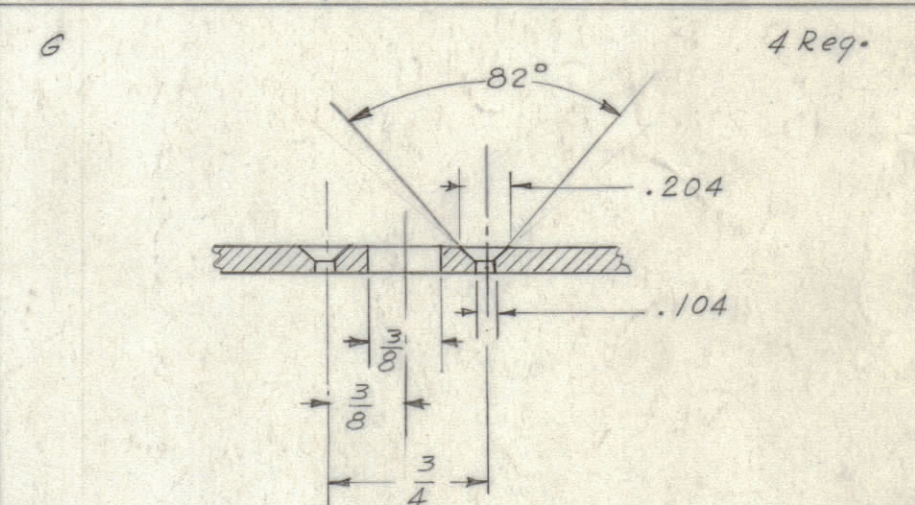
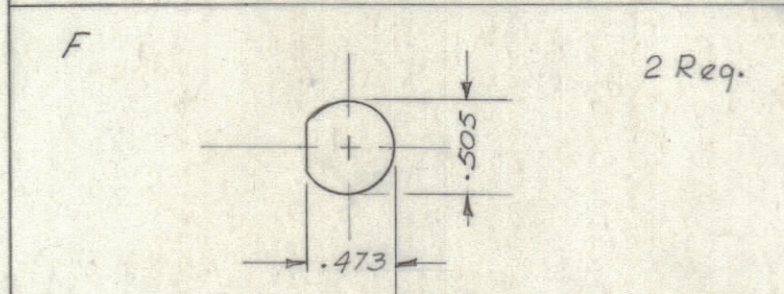
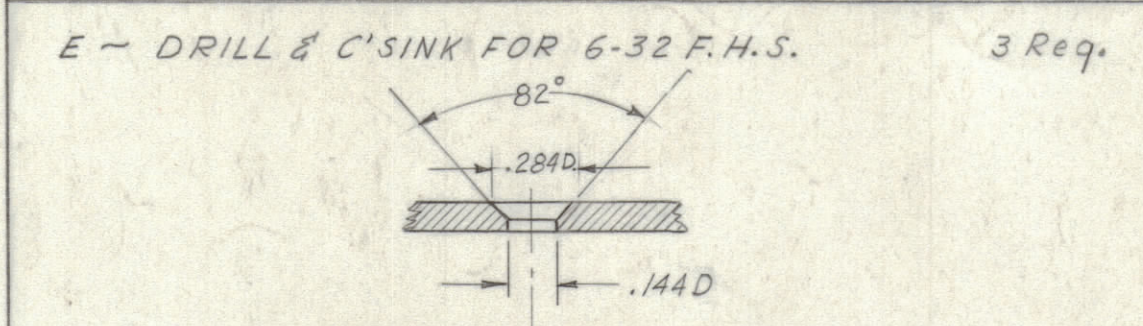

METAL STAMP TMC PART NO. AS SHOWN  $\frac{1}{8}$  HIGH GOTHIC.

|   |                  |
|---|------------------|
| UNLESS OTHERWISE SPECIFIED DIMENSIONS ARE IN INCHES AND INCLUDE CHEMICALLY APPLIED OR PLATED FINISHES |                  |
| DECIMALS ±.05   | FRACTIONS ± 1/64 |
| ANGLES ± 30°  | TOLERANCES       |

| SYM  | ZONE | DESCRIPTION                                   | DATE   | CH. NO. | DRAFTS | CHECKER | ENG. APP. |
|--|------|---|--|---------|--------|---------|-----------|
| A  | C4-3 | CHG 4 "A" HOLES 1/64 DIA. TO 1/32 x 1/64 SLOT | 2-4-64   | 10801   | A.M.   | TR      | VMB       |
| UNLESS OTHERWISE SPECIFIED: DIMENSIONS ARE IN INCHES         |      |   | SCALE FULL   |         |        |         |           |
| TOLERANCES ON FRACTIONS ± 1/64 DECIMALS ± .005 ANGLES ± 1/2° |      |   | MAXIMUM ALLOWABLE TOLERANCES HAVE BEEN DETERMINED AND ANY DEVIATIONS WILL BE CAUSE FOR REJECTION. REMOVE ALL BURRS & SHARP EDGES |         |        |         |           |

|                    |          |   |                        |
|--------------------|----------|---|------------------------|
| 4                  | 2        | NT-129-440-4  | NUT, ROUND, SWAGE TYPE |
| 6                  | 1        | NT-129-832-4  | NUT, ROUND, SWAGE TYPE |
| REQ. ITEM          | PART NO. | DESCRIPTION   |                        |
| .064               |          | THE TECHNICAL MATERIEL CORP. MAMARONECK, NEW YORK             |                        |
| ALUMINUM           |          | RIGHT SIDE PLATE  |                        |
| MATERIAL           |          |   |                        |
| 5052-H32           |          | DRAWN <i>WMB</i> CHECKED <i>WMB</i> FINAL APPROVAL <i>WMB</i> |                        |
| TYPE & TEMPER      |          | HEAT TREAT. SPEC.   |                        |
| 3404 YEL. IRIDITE  |          | MS-2615   |                        |
| FINISH & SPEC. NO. |          | ELEC. DES. APP. MECH. DES. APP. SHEET OF                      |                        |

REF: LD-954(2)

| REQ. PER UNIT | MODEL | SECTION | ASSY. NO. | DATE   |
|---------------|-------|---------|-----------|--------|
| 1             | GPE-1 |         |           | 6-6-61 |
| USED ON       |       |         |           |        |

MS-2615 A