

REQ. PER. UNIT	USED ON			MS-2557
	MODEL	ASS'Y. NO.	DATE	
	1	CPP-5	4-26-61	

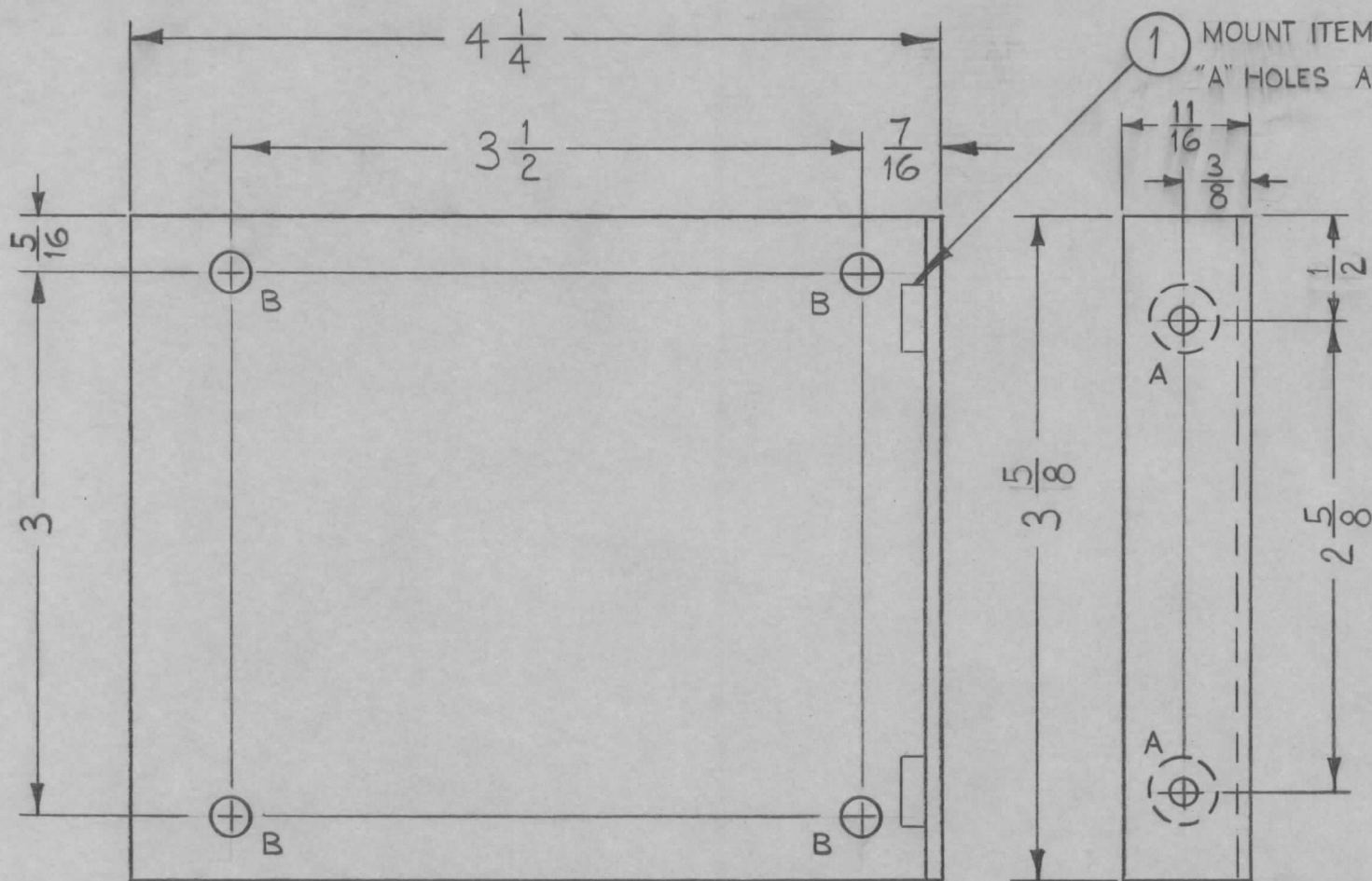

A~.221-.224 DIA. 2 REQ.
 B~ 7/32 DIA. 4 REQ.

		2	1	NT-129-832-4	NUT, ROUND, SWAGE TYPE			
ISSUE	ITEM	CHANGED FROM	DATE	CH. NO.	DRAFTS	CHECKER	ENG. APP.	
TOLERANCES			SCALE: FULL (DO NOT SCALE)					
DEC. DIM. ±			MAXIMUM ALLOWABLE TOLERANCES HAVE BEEN DETERMINED AND ANY DEVIATIONS WILL BE CAUSE FOR REJECTION. REMOVE ALL BURRS AND SHARP EDGES					
FRAC. DIM. ± 1/64								
ANGULAR DIM. ±								
		.081		ALUMINUM			THE TECHNICAL MATERIEL CORP. MAMARONECK, NEW YORK	
		STOCK SIZE		MATERIAL			TRANSFORMER, SUPPORT BRACKET	
		5052-H32		S404 YELL; IRIDITE			W.A.F. [Signature]	
		TYPE & TEMPER		HEAT TREAT. SPEC.			DRAWN [Signature]	
		FINISH & SPEC. NO.		ELEC. DES. APP			MECH. DES. APP [Signature]	
							MS-2557	