

MS-2502

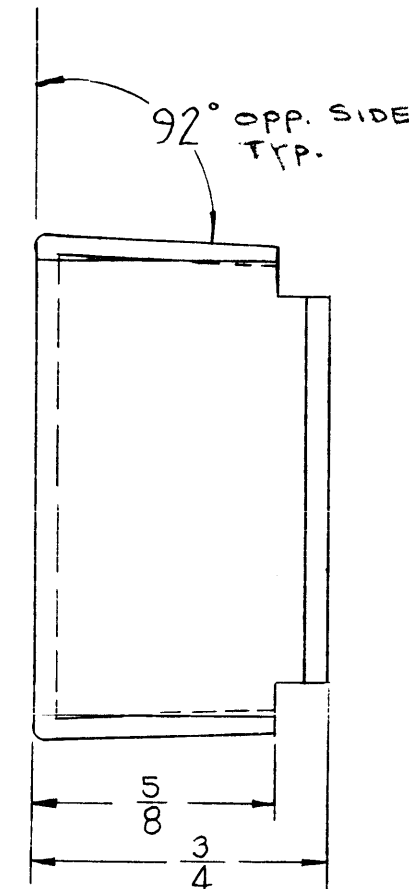

A ~ 1/8 2 REQ
B ~ 11/64 2 REQ

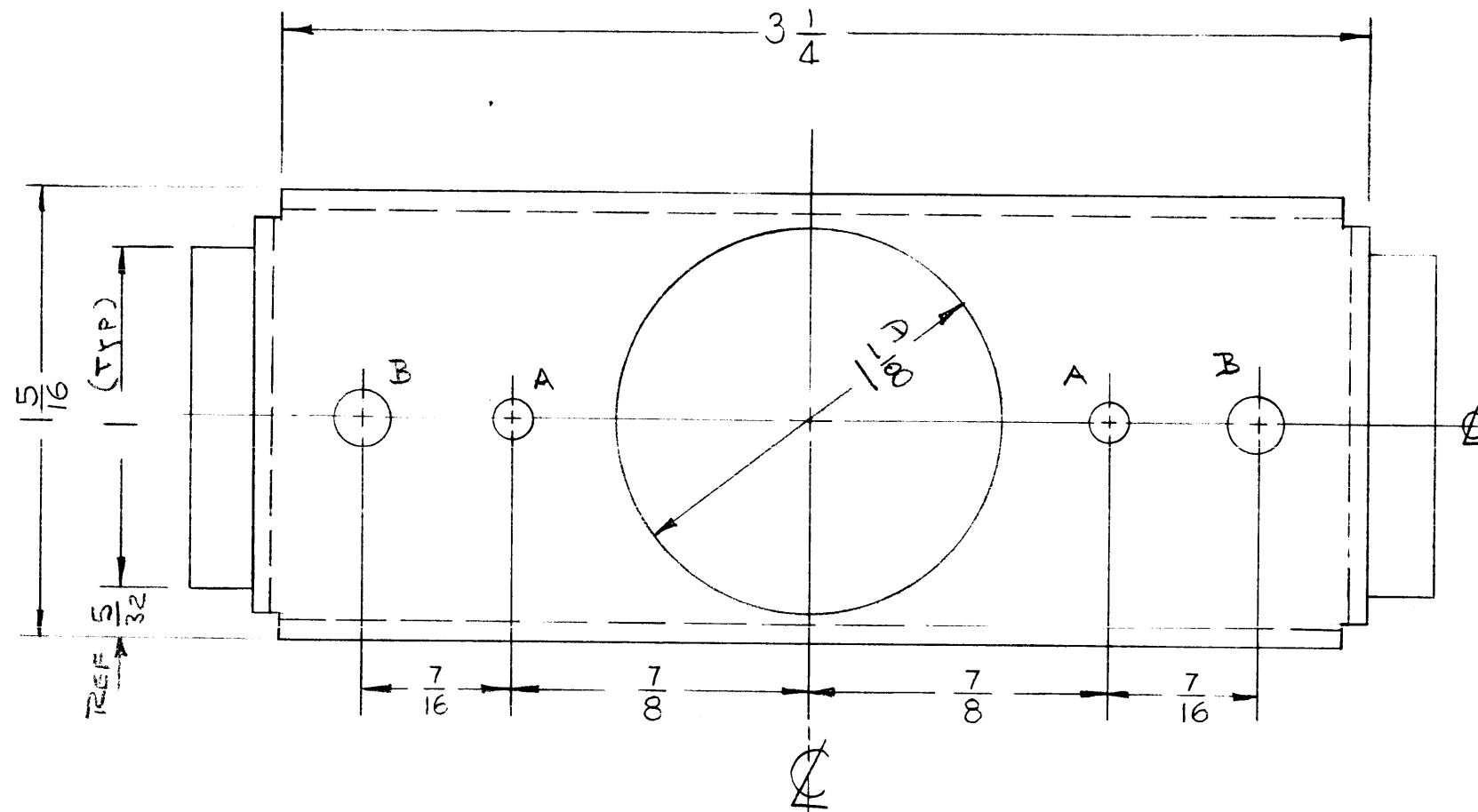
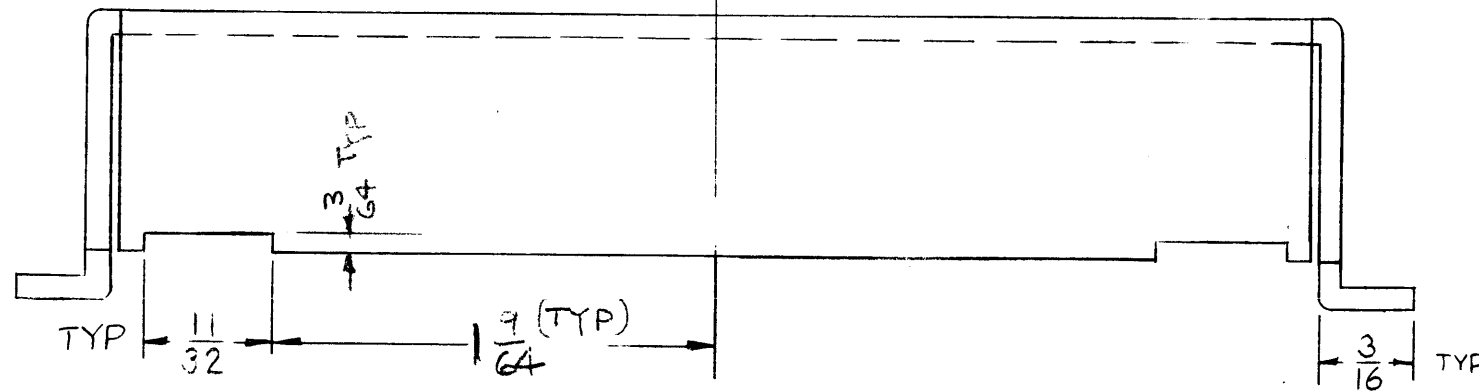

~NOTE~
USE MATERIAL THICKNESS FOR
MAX. RADIUS ON BEND, UNLESS
OTHERWISE SPECIFIED.

OPPOSITE SIDE
IDENTICAL

SYM	DESCRIPTION	DATE	CH. NO.	DRAFTS	CHECKER	ENG. APP.
UNLESS OTHERWISE SPECIFIED: DIMENSIONS ARE IN INCHES TOLERANCES ON FRACTIONS ± 1/64 DECIMALS ± .005 ANGLES ± 1/2°		SCALE: DOUBLE SIZE MAXIMUM ALLOWABLE TOLERANCES HAVE BEEN DETERMINED AND ANY DEVIATIONS WILL BE CAUSE FOR REJECTION. REMOVE ALL BURRS AND SHARP EDGES				

REQ. PER UNIT	MODEL	SECTION	ASS'Y. NO.	DATE
USED ON				

REQ. ITEM	PART NO.	DESCRIPTION		SYMBOL
18 GA		THE TECHNICAL MATERIEL CORP. MAMARONECK, NEW YORK		
STEEL		RECEPTACLE BOX		
MATERIAL		R. UZZO	8. JEM	
TYPE & TEMPER	HEAT TREAT. SPEC.	DRAWN	CHECKER	FINAL APPROVAL
S115 TMC GRAY		86.		MS-2502
FINISH & SPEC. NO.		ELEC. DES. APP.	MECH. DES. APP.	