

A-3/8 DIA. 8 REQ  
 B- .224 DIA (For Mounting Item) 2 "

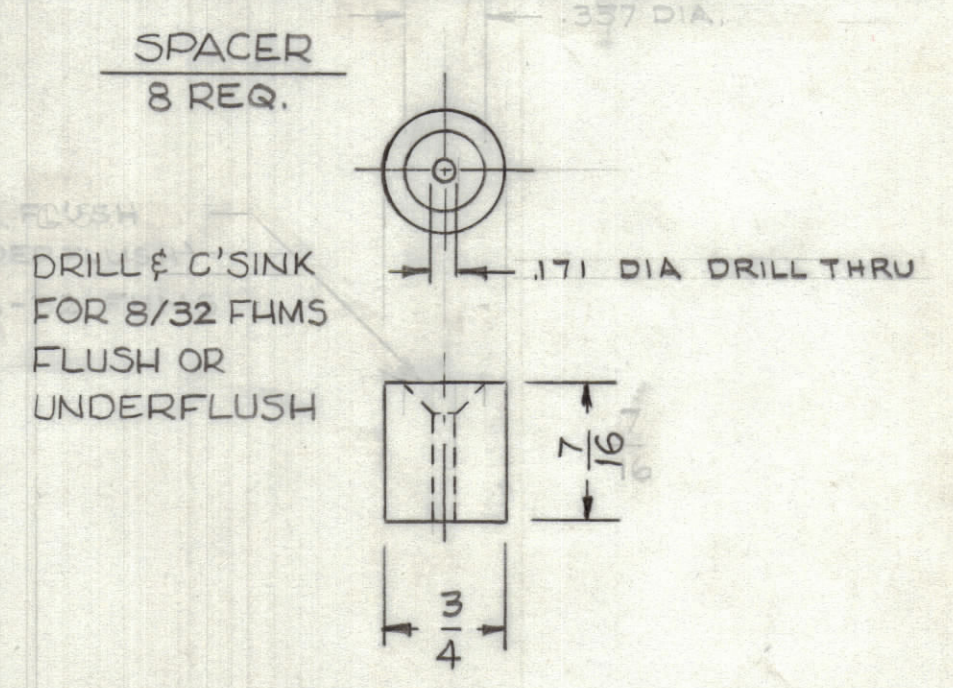
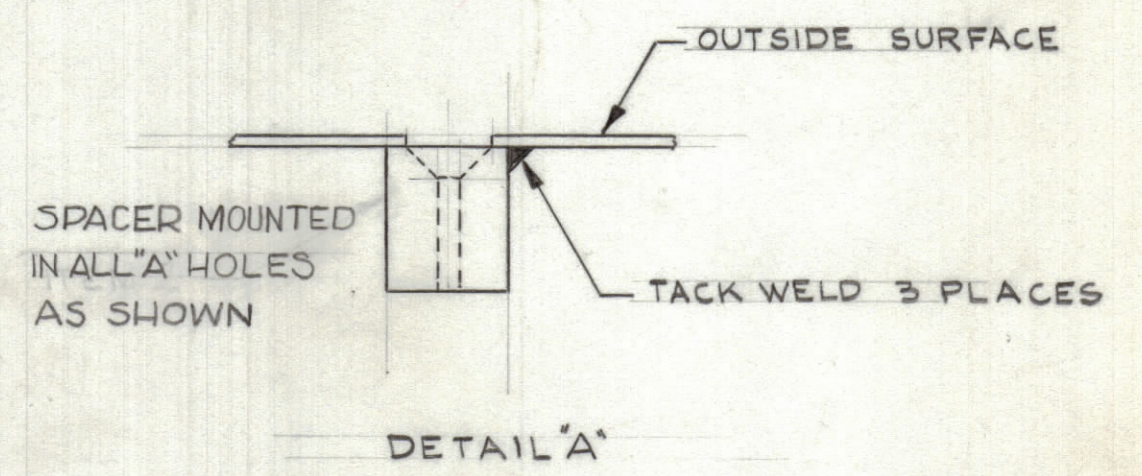

NOTE ITEM-2 USE MATERIAL THICKNESS FOR MAX. RADIUS ON ALL BENDS UNLESS OTHERWISE SPECIFIED

FINISH NOTE ALL SURFACES S-404 YELLOW IRIDITE S-114 ZINC CHROMATE S-220 RCAF BLUE GRAY ENAMEL (OR PRIME & PAINT)

2	1	NT-179-832-3	Nut, Round, Swage type	
REQ.	ITEM	PART NO.	DESCRIPTION	SYMBOL
		16 GA	THE TECHNICAL MATERIEL CORP. MAMARONECK, NEW YORK	
		COLD STEEL	RIGHT SIDE PANEL	
		COLD ROLL		
		SEE FINISH NOTE		
		FINISH & SPEC. NO.	ELEC. DES. APP.	MECH. DES. APP.
				MS-2428
				SHEET OF

UNLESS OTHERWISE SPECIFIED DIMENSIONS ARE IN INCHES AND INCLUDE CHEMICALLY APPLIED OR PLATED FINISHES

DECIMALS FRACTIONS  
 .X ± .05 TOLERANCES ± 1/64  
 .XX ± .01 ANGLES ± 0° 30'  
 .XXX ± .005

CUT HERE GUARANTEED 2-66

SYM	ZONE	DESCRIPTION	DATE	CH. NO.	DRAFTS	CHECKER	ENG. APP.
UNLESS OTHERWISE SPECIFIED:							
DIMENSIONS ARE IN INCHES			SCALE DO NOT SCALE				
TOLERANCES ON FRACTIONS ± 1/64 DECIMALS ± .005 ANGLES ± 1/2°			MAXIMUM ALLOWABLE TOLERANCES HAVE BEEN DETERMINED AND ANY DEVIATIONS WILL BE CAUSE FOR REJECTION. REMOVE ALL BURRS & SHARP EDGES				

1	ACU			4-12-61
REQ. PER UNIT	MODEL	SECTION	ASS'Y. NO.	DATE