

IF IT IS FOUND DESIRABLE TO CHANGE ANY TOLERANCE OR OTHER DETAIL SPECIFIED ON THIS DRAWING NOTIFY THE PURCHASER PROMPTLY.

MAXIMUM ALLOWABLE TOLERANCES HAVE BEEN DETERMINED AND DEVIATIONS WILL BE CAUSE FOR REJECTION. REMOVE ALL BURRS AND SHARP EDGES

MS-215 C

REQ. PER UNIT	USED ON			
	MODEL	PROJECT NO.	ASS'Y. NO.	DATE
1	XFK			7-30-51

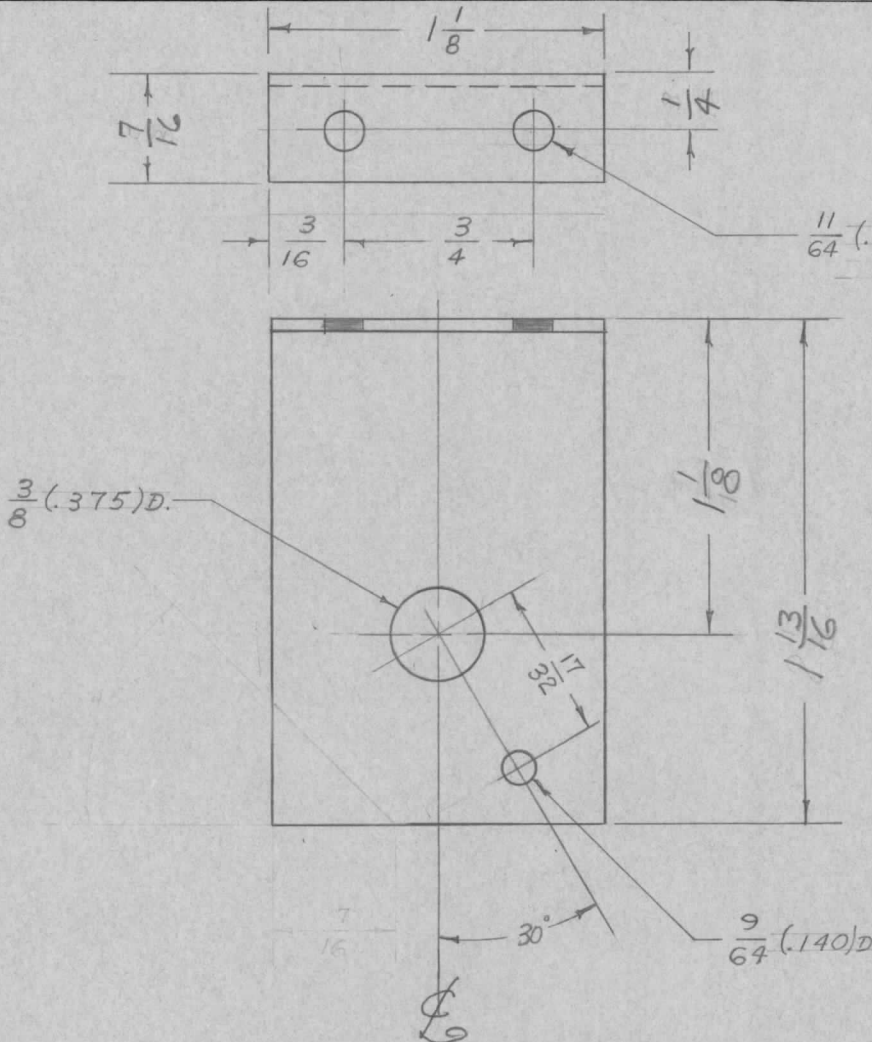

REQ.	ITEM	PART NO.	DESCRIPTION	SYMBOL
		.064	THE TECHNICAL MATERIEL CORP. MAMARONECK. NEW YORK	
		STOCK SIZE		
		ALUMINUM	S2D MOUNTING PLATE	
		WEIGHT PER PC.		
		5052 B H32	AD. 8-16-55	
		TYPE & TEMPER		
		#	DRAWN	ELEC. DES. APP.
			HECKED	FINAL APPROVAL
		HEAT TREAT. SPEC.		
		S-404 IRIDITE		MS-215 C
		FINISH & SPEC. NO.		

ISSUE	ITEM	CHANGED FROM	DATE	CN. NO.	DRAFTS	CHECKER	ENG. APP.
C	1	S404 IRIDITE WAS S101 CAUSTIC DIP	12-7-59	1001	P		EMN
B	1	REDRAWN TO 4/16/55	4/16/55	2	AB	JAW	WJC

TOLERANCES	SCALE
DEC. DIM. ± FRAC. DIM. ± Y64 ANGULAR DIM. ± 1°	DRILL, PUNCH, COMMERCIAL STOCK SIZES AND MANUFACTURERS TOLERANCES ARE NOT INCLUDED.