

MS-1669 K

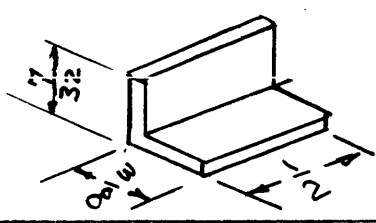

CLIP DETAIL
20 GA. STL.
3 REQ

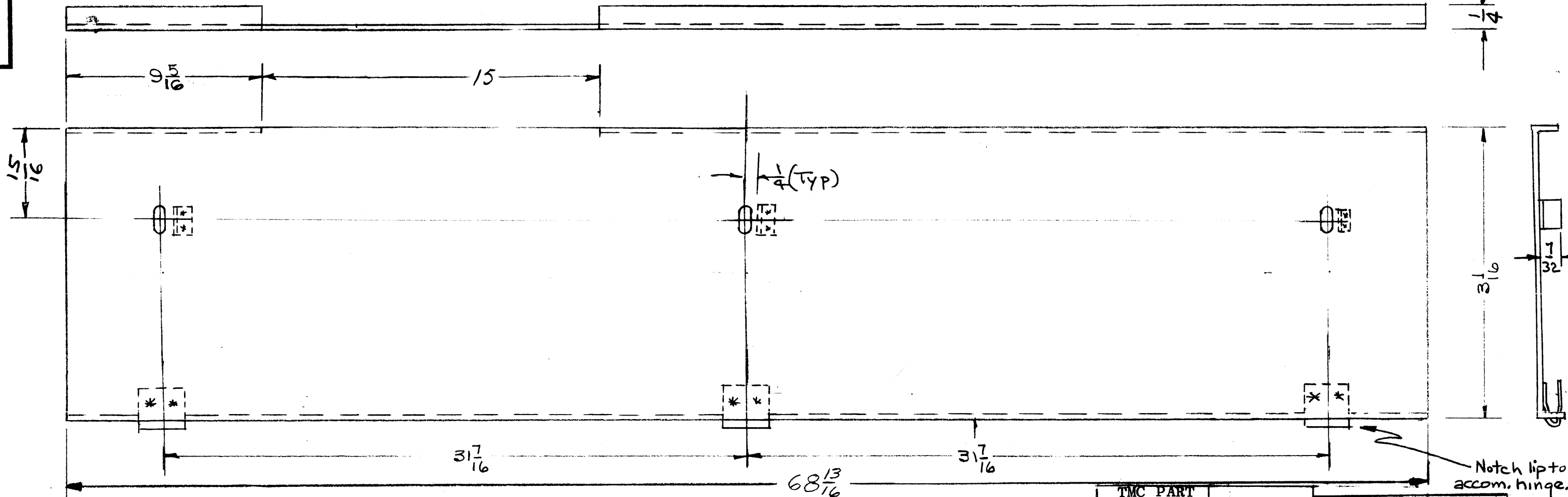

ISSUE	ITEM	CHANGED FROM	DATE	CH. NO.	DRAFTS	CHECKER	ENG. APP.
K		FINISH S521 WAS S115	5-31-66	16237	H.L.A.		
J	1	CHART ADDED	11-9-65	15239	H.V.V.		
H	1	DIM. 9 5/16 WAS 7 1/16	7-3-63	9448			
G	1	15" WAS 14 1/8	6-14-61	5056	J.C.B.		
F	4	13/64 D. hole deleted	6/11/60	2466	J.C.B.		
F	3	Notch was 1/8 x 5/8					
F	2	CHIPS added					
F	1	HING added					
E	1	DELETE (1) "B" HOLE	4-27-60	2193	CY		
D	4	"B" HOLE WAS 3/8 D					
D	3	3/8 WAS 5/16					
D	2	1 1/2 WAS 1 3/16	3-18-60	1904	M.S.		
D	1	7/16 WAS 7 9/16					
C	2	1 3/16 WAS 8 10/16	11/4/59	1518	an		
C	1	7 9/16 WAS 12 13/16					
B		ADDED 3 1/16 OMITTED 2 1/16	7/1/59				
A	4	THICKNESS WAS .064			J.C.B.		
A	3	MAT'L. WAS ALUMINUM					
A	2	68-13/16 DIM WAS 68-5/16	6/9/59				
A	1	8-15/16 DIM WAS 8-7/8					

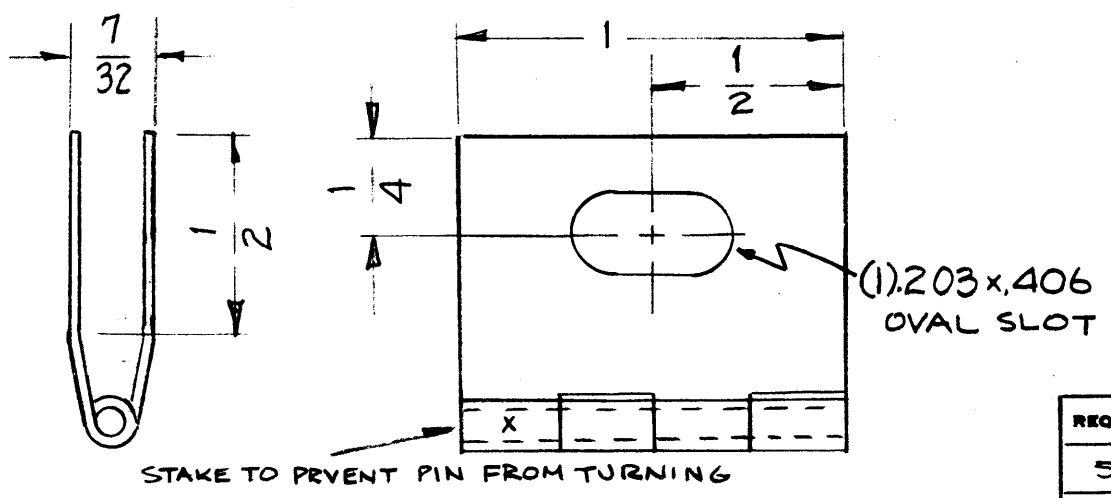

TMC PART NUMBER	MATL	FINISH
MS1669	20GA STEEL	S371, S114, S521
MS1669-2	20GA STEEL	S371, S114, S520
MS1669-3	.032 ALUM 5052-H32	S404, S114, S521

S114 ZINC CHROMATE PRIMER
S521 TEXTURED GRAY ENAMEL
S371 DEGREASE
S520 BLUE-GRAY TEXTURED VINYL
S404 IRIDITE, YELLOW

FINISH PER CHART

REQ. PER UNIT	MODEL	ASS'Y. NO.	DATE
1	GPT-40K		4-28-60
1	GPT-10KF()	AX-	
1	GPT-10KD()	AX-18B	
1	GPT-10KB()	AX-185	
1	GPT-10KA(), C(), E(), L()	AX-166	3-19-59

REQ. ITEM	PART NO.	DESCRIPTION	SYMBOL
SEE CHART		THE TECHNICAL MATERIEL CORP.	
SEE CHART		MAMARONECK, NEW YORK	
SEE CHART		TRIM, REAR, CENTER	
SEE CHART			
TYPE & TEMPER	HEAT TREAT. SPEC.	DRAWN	CHECKED
SEE CHART		J.C.B.	J.C.B.
FINISH & SPEC. NO.		ELEC. DES. APP.	MECH. DES. APP.
			MS-1669 K