

REQ. PER. UNIT	USED ON			MS-1662 A
	MODEL	ASS'Y. NO.	DATE	
1	GPT-10K	AUX		

A ~ .194
.191 DIA. HOLE (2 REQ)

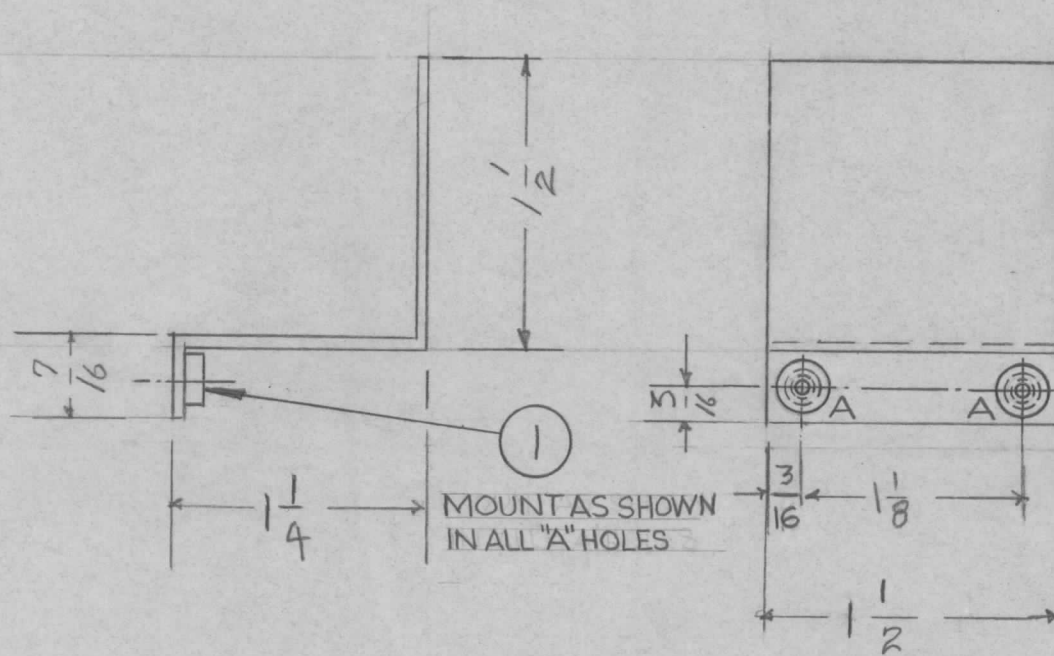

UNLESS OTHERWISE SPECIFIED
DIMENSIONS ARE IN INCHES AND INCLUDE
CHEMICALLY APPLIED OR PLATED FINISHES

DECIMALS	TOLERANCES	FRACTIONS
.X ± .05		± 1/64
.XX ± .01		ANGLES
.XXX ± .005		± 0° 30'

CUT HERE
GUARANTEED
2-66

		2	1	NT129-632-4	NUT, SWAGE TYPE			
		REQ.	ITEM	PART NO.		DESCRIPTION		SYMBOL
				.064		THE TECHNICAL MATERIEL CORP.		
				STOCK SIZE		MAMARONECK, NEW YORK		
				ALUM.		Cover		
				MATERIAL		UTILITY - OUTLET PANEL		
				5052-H32		[Signature]		
				TYPE & TEMPER		DRAWN		FINAL APPROVAL
				HEAT TREAT. SPEC.		CHECKED		
				5404 1R/dite		[Signature]		MS-1662 A
				FINISH & SPEC. NO.		ELEC. DES. APP		MECH. DES. APP

A	1	ADDED ITEM (1); (2) "A" HOLES WERE 3/16 DIA.	7-29-63	9666	AK.	YAG	[Signature]
ISSUE	ITEM	CHANGED FROM	DATE	CH. NO.	DRAFTS	CHECKER	ENG. APP.

TOLERANCES

SCALE:

DEC. DIM. ±
FRAC. DIM. ±
ANGULAR DIM. ±

MAXIMUM ALLOWABLE TOLERANCES HAVE BEEN DETERMINED AND ANY DEVIATIONS WILL BE CAUSE FOR REJECTION.
REMOVE ALL BURRS AND SHARP EDGES