

IF IT IS FOUND DESIRABLE TO CHANGE ANY TOLERANCE OR OTHER DETAIL SPECIFIED ON THIS DRAWING NOTIFY THE PURCHASER PROMPTLY.		DIMENSIONS IN INCHES UNLESS OTHERWISE SPECIFIED					
MAXIMUM ALLOWABLE TOLERANCES HAVE BEEN DETERMINED AND DEVIATIONS WILL BE CAUSE FOR REJECTION. REMOVE ALL BURRS AND SHARP EDGES.							
ISSUE	ITEM	CHANGED FROM	DATE	CN. NO.	DRAFTS	CHECKER	ENG. APP.
Ø		RELEASE TO PROD	OCT 14/69		PW		
A		REV PER CEMIL	JAN 7/71	1032	NAT.		

REQ.	ITEM	PART NO.	DESCRIPTION	SYMBOL
------	------	----------	-------------	--------

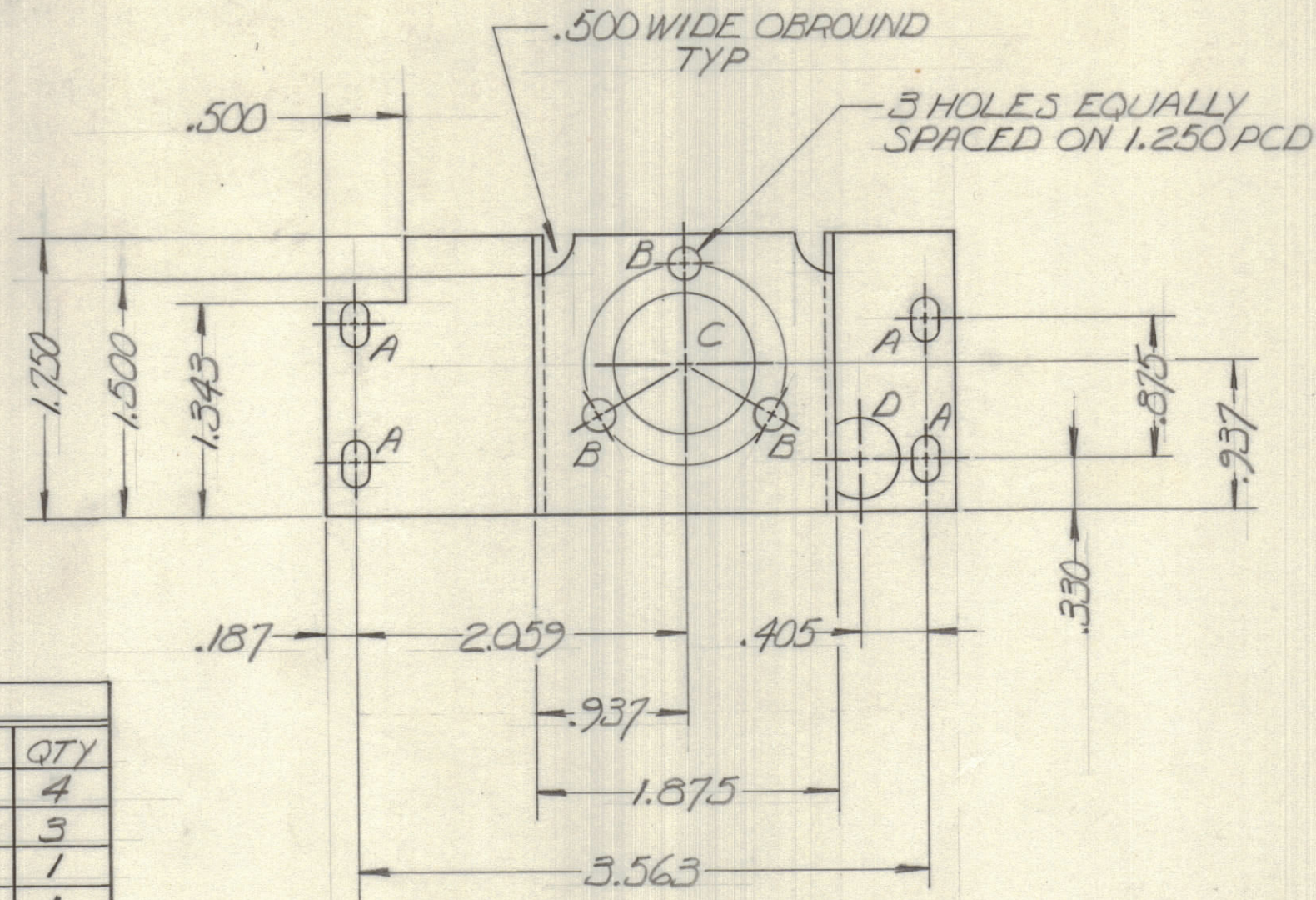

HOLE TABLE		
LTR	DESCRIPTION	QTY
A	.281 X .140 OBROUND	4
B	.171 DIA	3
C	.937 DIA	1
D	.500 DIA	1

MS11106 A

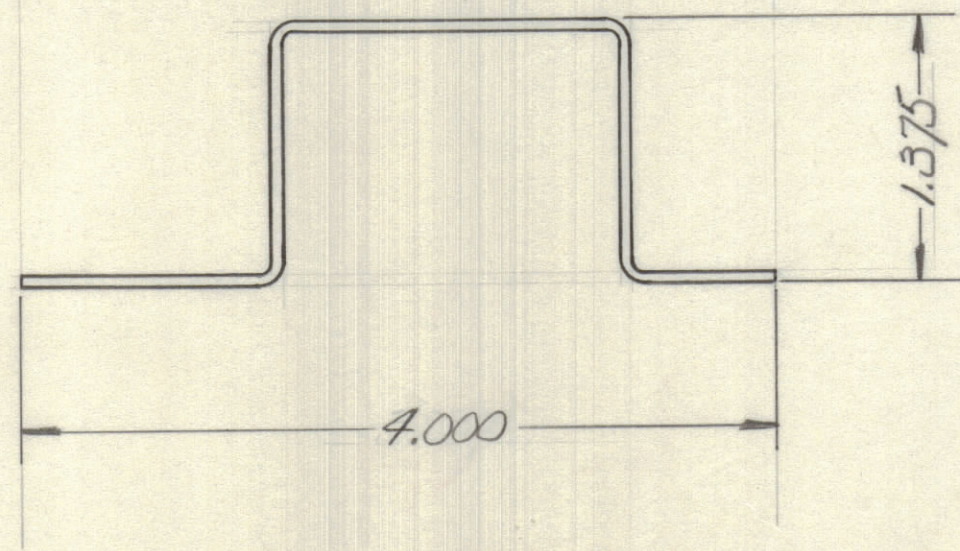

MINIMUM INSIDE BEND RADIUS, .062

METAL STAMP TMC PART NO, 1/8 HIGH, GOTHIC.

TOLERANCES		SCALE: 1/1
ALL OTHERS	DEC. DIM. ± .015 FRAC. DIM. ± 1/64 ANGULAR DIM. ± 0° 30'	DRILL, PUNCH, COMMERCIAL STOCK SIZES AND MANUFACTURERS TOLERANCES ARE NOT INCLUDED.

LPA	088-69	7 OCT 69
MODEL	PROJECT NO.	DATE

.062 THK	TMC (Canada) LIMITED OTTAWA ONTARIO	
ALALY	SUPPORT -	
575-H32	MOTOR, ASSY	
TYPE & TEMPER	FWILLIAMS	
HEAT TREAT. SPEC.	IRIDITE S40A	
FINISH & SPEC. NO.		