

ISSUE	ITEM	CHANGED FROM	DATE	CN. NO.	DRAFTS	CHECKER	ENG. APP.	REQ.	ITEM	PART NO.	DESCRIPTION	SYMBOL
-------	------	--------------	------	---------	--------	---------	-----------	------	------	----------	-------------	--------

UNLESS OTHERWISE SPECIFIED:

1. USE MATERIAL THICKNESS FOR MAXIMUM RADIUS ON ALL BENDS
2. ALL ANGULAR BENDS 90 DEGREES
3. REMOVE ALL BURRS AND SHARP EDGES
4. MOUNT INSERTS AFTER FINISHING

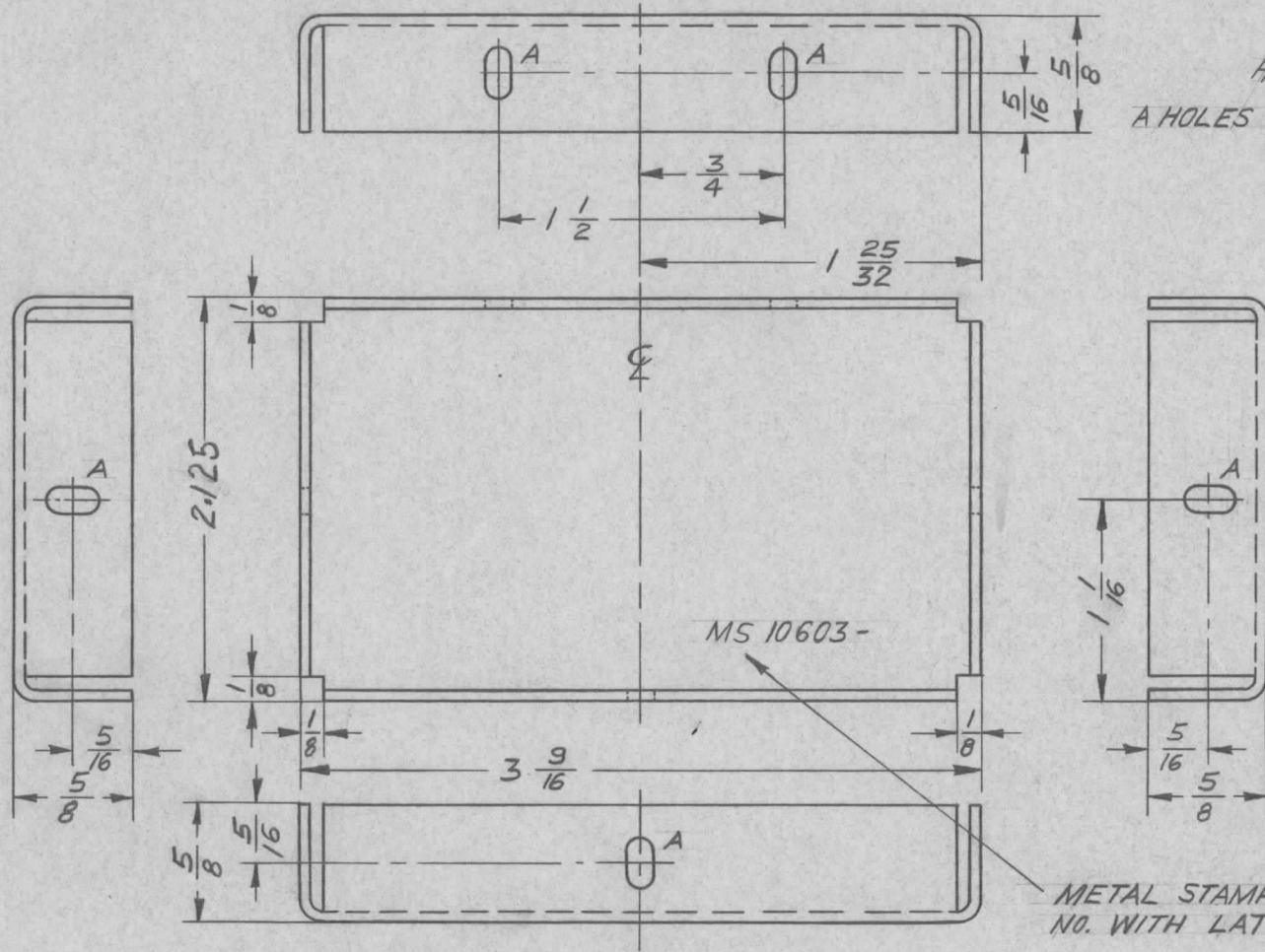

HOLE LEGEND  
 A HOLES 9/64 x 9/32, 5 REQ'D  
 SLOTTED

METAL STAMP ON REAR TMC PART NO. WITH LATEST REVISION LETTER.

AMC 20		020/65		A 10 374		18-10-65		.064 THK.		TMC (Canada) LIMITED OTTAWA ONTARIO					
MODEL		PROJECT NO.		ASS'Y. NO.		DATE		STOCK SIZE		BRACKET, MODULE HOUSING					
USED ON								ALUM.		LEFT - RIGHT					
MAXIMUM ALLOWABLE TOLERANCES HAVE BEEN DETERMINED AND DEVIATIONS WILL BE CAUSE FOR REJECTION. REMOVE ALL BURRS AND SHARP EDGES				IF IT IS FOUND DESIRABLE TO CHANGE ANY TOLERANCE OR OTHER DETAIL SPECIFIED ON THIS DRAWING NOTIFY THE PURCHASER PROMPTLY.				MATERIAL		WEIGHT PER PC.		DRAWN		ELEC. DES. APP.	MECH. DES. APP.
								575 H32				Hus.		J. King	BEP
TOLERANCES				SCALE 1:1				TYPE & TEMPER		CHECKED		FINAL APPROVAL			
ALL OTHERS		DEC. DIM. ± .005		DIMENSIONS IN INCHES UNLESS OTHERWISE SPECIFIED				HEAT TREAT. SPEC.		MS 10 603		φ			
		FRAC. DIM. ± 1/64		DRILL, PUNCH, COMMERCIAL STOCK SIZES AND MANUFACTURERS TOLERANCES ARE NOT INCLUDED.				S 404 YELLOW IRIDITE							
		ANGULAR DIM. ± 0°30'						FINISH & SPEC. NO.							