

IF IT IS FOUND DESIRABLE TO CHANGE ANY TOLERANCE OR OTHER DETAIL SPECIFIED ON THIS DRAWING NOTIFY THE PURCHASER PROMPTLY.

RELEASED

MS-132 c

MAXIMUM ALLOWABLE TOLERANCES HAVE BEEN DETERMINED AND DEVIATIONS WILL BE CAUSE FOR REJECTION. REMOVE ALL BURRS AND SHARP EDGES

REQ. PER UNIT	USED ON			
	MODEL	PROJECT NO.	ASS'Y. NO.	DATE
	FFR	104	A-131	9-9-52
	FFR	104	A-162	9-30-52
	LFA	109	A-208	10-24-52
6	GPR			6-17-55
2	FFRD-1,2,3	E-458-P		4/16/56
	MSR		A-1495 A-2007	10/3/61

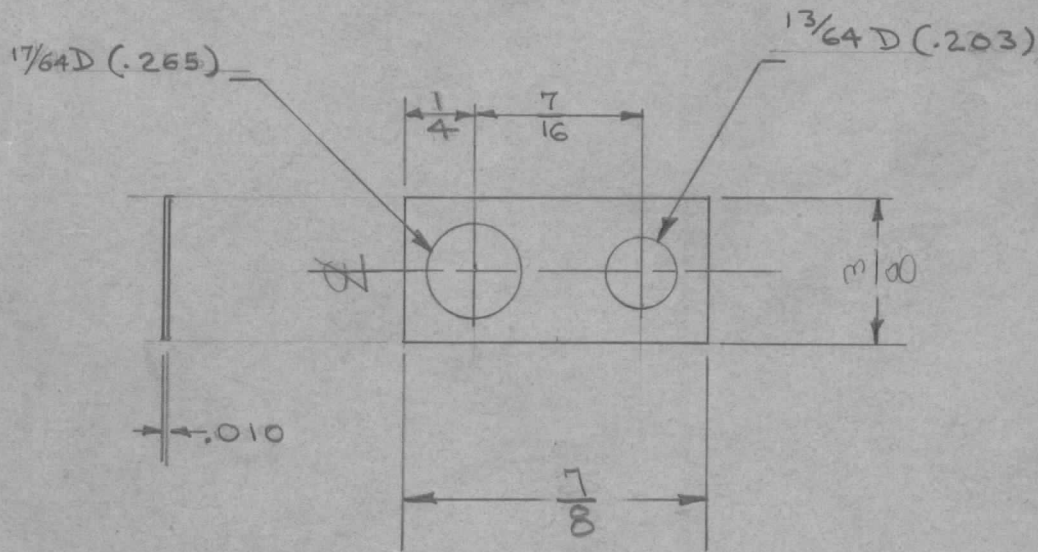

UNLESS OTHERWISE SPECIFIED DIMENSIONS ARE IN INCHES AND INCLUDE CHEMICALLY APPLIED OR PLATED FINISHES

DECIMALS	TOLERANCES	FRACTIONS
.X ± .05		± 1/64
.XX ± .01		ANGLES
.XXX ± .005		± 0° 30'

CUT HERE GUARANTEED 2-56

C	1	3/8 WAS 17/16	8/14/56	3	CBS	JAL	WJ
B	1	17/64 D. WAS 1/4 D.	2/8/55	2	FB	JAL	WJ
A	1	THICKNESS WAS .005	6/22/53	1	C.D.D.	JAL	WJ
ISSUE	ITEM	CHANGED FROM	DATE	CN. NO.	DRAFTS	CHECKER	ENG. APP.

REQ.	ITEM	PART NO.	DESCRIPTION	SYMBOL
		.010	THE TECHNICAL MATERIEL CORP. MAMARONECK, NEW YORK	
		PHOSPHOR BRONZE	GROUNDING STRAP	
		MATERIAL	IF CORE	
		WEIGHT PER PC.	AD. 9-9-52 G.T.O	
		TYPE & TEMPER	DRAWN	ELEC. DES. APP. MECH. DES. APP.
		HEAT TREAT. SPEC.	CHECKED	FINAL APPROVAL
		5-105 CADMIUM PLATE .0002		
		FINISH & SPEC. NO.		

TOLERANCES		SCALE
ALL OTHERS	DEC. DIM. ± FRAC. DIM. ± ANGULAR DIM. ±	DRILL, PUNCH, COMMERCIAL STOCK SIZES AND MANUFACTURERS TOLERANCES ARE NOT INCLUDED.

MS-132 c