

REQ. PER UNIT	USED ON			MS-1067	A
	MODEL	ASS'Y. NO.	DATE		
1	A-1421		7-26-57		

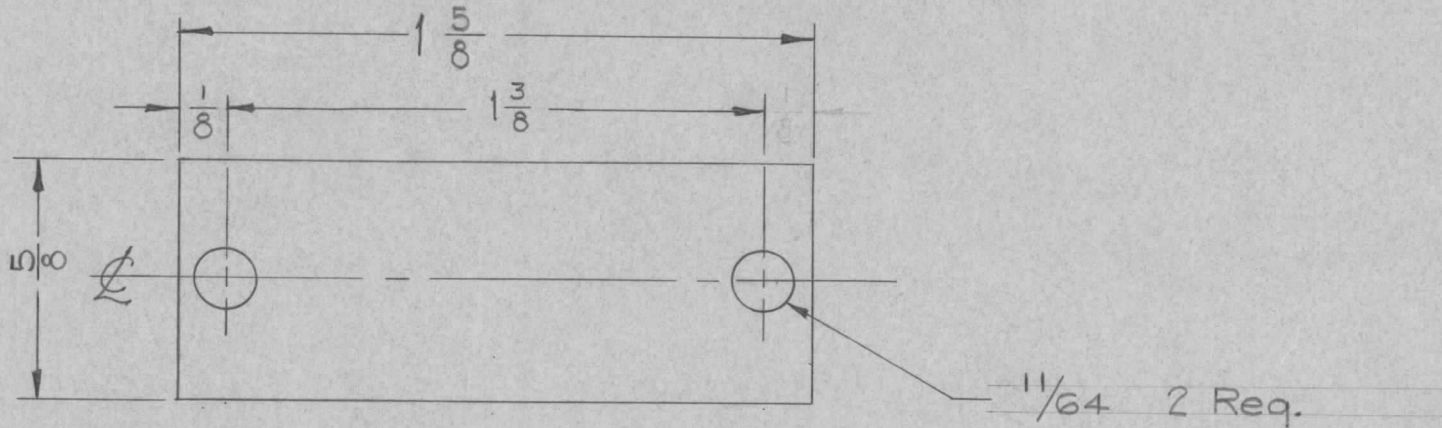

UNLESS OTHERWISE SPECIFIED
DIMENSIONS ARE IN INCHES AND INCLUDE
CHEMICALLY APPLIED OR PLATED FINISHES

DECIMALS	TOLERANCES	FRACTIONS
.X ± .05		± 1/64
.XX ± .01		ANGLES
.XXX ± .005		± 0° 30'

CUT HERE
GUARANTEED
2-66

NOTE:
S404 IRIDITE
E107 LACQUER

REQ. ITEM	PART NO.	DESCRIPTION	SYMBOL										
	.064	THE TECHNICAL MATERIEL CORP. MAMARONECK, NEW YORK	RETAINING PLATE										
	STOCK SIZE												
A 1	S404-IRIDITE WAS S101-CAUSTIC DIP												
ISSUE	ITEM	CHANGED FROM	DATE	CH. NO.	DRAFTS	CHECKER	ENG. APP.						
			12-8	1001	SP		EMN						
TOLERANCES		SCALE:		5052-H32		7-26-57		fale		MS-1067		A	
DEC. DIM. ±		MAXIMUM ALLOWABLE TOLERANCES HAVE		TYPE & TEMPER		HEAT TREAT. SPEC.		DRAWN		CHECKED		FINAL APPROVAL	
FRAC. DIM. ±		BEEN DETERMINED AND ANY DEVIATIONS		SEE NOTE									
ANGULAR DIM. ±		WILL BE CAUSE FOR REJECTION.		FINISH & SPEC. NO.		ELEC. DES. APP.		MECH. DES. APP.					
		REMOVE ALL BURRS AND SHARP EDGES											