

THE CONTENTS OF THIS DRAWING ARE THE EXCLUSIVE PROPERTY OF THE TECHNICAL MATERIAL CORP. ITS UNAUTHORIZED USE OR REPRODUCTION IN WHOLE OR IN PART IS STRICTLY FORBIDDEN.

SEE DETAIL AT RIGHT FOR DIAL FACE

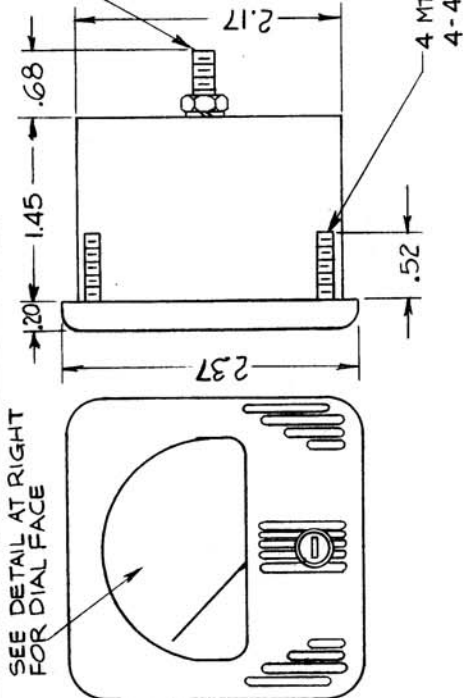

STAMP CASE AS SHOWN.

2 TERMINALS 1/4-28

TMC MR-160-B

4 MTG. STUDS 4-40 THDS

MR-160

NOTE: CASE FRONT MUST BE A BLACK MATT FINISH, WITH LINE DESIGN AS SHOWN.

SPECIFICATIONS:

- 1- CASE-STANDARD SIMPSON NO. 127 OR EQUIVALENT
- 2- MOVEMENT- 0-1 MILLI AMPS
- 3- APPROX.- RESISTANCE - 75 OHMS $\pm 50\%$
- 4- POINTER TYPE- KNIFE EDGE. ALL NECESSARY MOUNTING & TERMINAL HARDWARE SUPPLIED BY MFG.
- 5- ACCURACY AT FULL SCALE $\pm 2\%$
- 6- CALIBRATED FOR NON-MAGNETIC PANEL

WHITE BACKGROUND

BLACK LINE WORK

TMC INSIGNIA BLACK FULL SCALE

SCALE = 3X

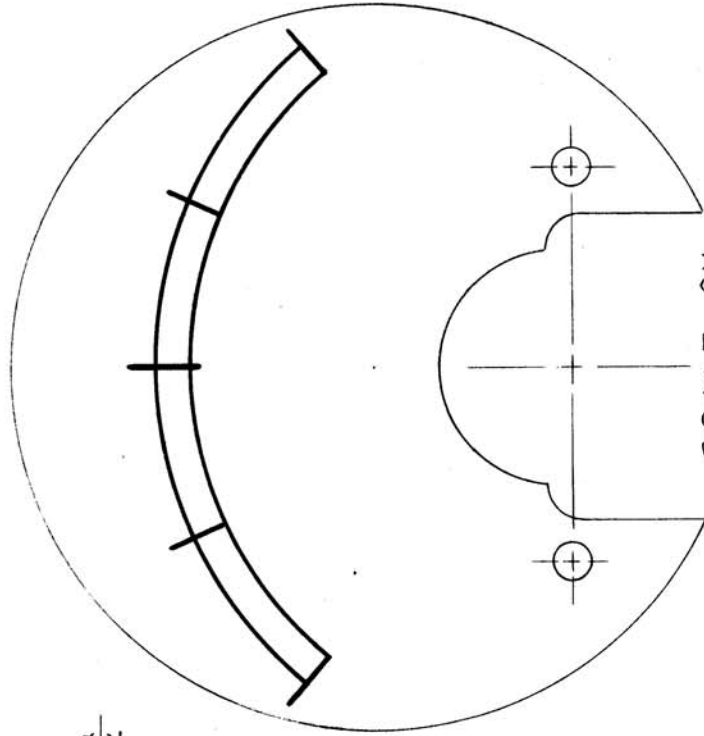

BYM	DESCRIPTION	DATE	CH. NO.	DRAFTS	CHECKER	ENG. APP.
B	SPECS #5 & 6 ADDED; REF CODE ADDED	1-11-63	9128			
A	SPEC #1, 2, 3, 4, 5, 6, 7, 8, 9, 10, 11, 12, 13, 14, 15, 16, 17, 18, 19, 20, 21, 22, 23, 24, 25, 26, 27, 28, 29, 30, 31, 32, 33, 34, 35, 36, 37, 38, 39, 40, 41, 42, 43, 44, 45, 46, 47, 48, 49, 50, 51, 52, 53, 54, 55, 56, 57, 58, 59, 60, 61, 62, 63, 64, 65, 66, 67, 68, 69, 70, 71, 72, 73, 74, 75, 76, 77, 78, 79, 80, 81, 82, 83, 84, 85, 86, 87, 88, 89, 90, 91, 92, 93, 94, 95, 96, 97, 98, 99, 100	6-18-63	9243			
	A	MTG STUDS WERE 4-36 THD				

UNLESS OTHERWISE SPECIFIED:

DIMENSIONS ARE IN INCHES
TOLERANCES ON FRACTIONS $\pm 1/64$ DECIMALS $\pm .005$ ANGLES $\pm 1/20$

MAXIMUM ALLOWABLE TOLERANCES HAVE BEEN DETERMINED AND ANY DEVIATION WILL BE CAUSE FOR REJECTION. REMOVE ALL BURRS AND SHARP EDGES

REQ. NO.	SECTION	ABTY. NO.	DATE
1	HFB-1/C		7-24-62

USED ON

REQ. ITEM	PART NO.	DESCRIPTION	SYMBOL
		THE TECHNICAL MATERIAL CORP. MAMARONECK, NEW YORK	
		METER, PHASE COMPARTOR	
		V.R.R. <i>V.R.R.</i> DRAWN <i>BP</i> CHECKED <i>BP</i> FINAL APPROVAL <i>BP</i>	
		TYPE & TEMPER HEAT TREAT. SPEC.	
		FINISH & SPEC. NO.	MR-160 B