

T.M.C. PART NO.	REF: T.M.C. PART NO.	TAP	KEYWAY	DRILL THRU CENTER HOLE
MP-128-1	MP-127-10	G-32 X 1/2 DP	1/16 X .070 DP	YES

REQ. PER UNIT	USED ON			MP-128 0
	MODEL	ASS'Y. NO.	DATE	
1	GPT-200K (AX-395)	A 3260	11-12-63	

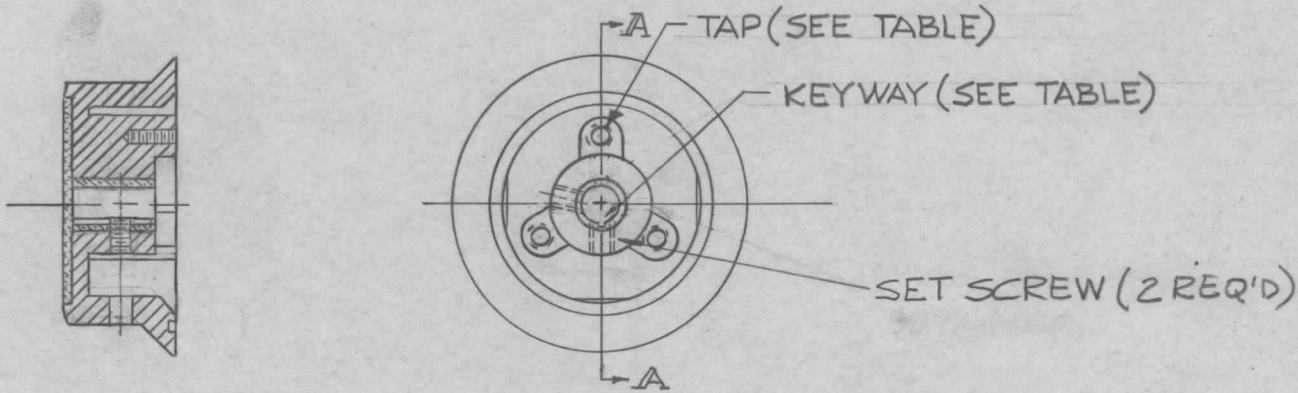

SECTION A-A

TO BE MODIFIED BY MANUFACTURER

REQ.	ITEM	PART NO.	DESCRIPTION				SYMBOL
			THE TECHNICAL MATERIEL CORP. MAMARONECK. NEW YORK				
			STOCK SIZE				
0	ORIGINAL RELEASE FOR PRODUCTION	2-2564	MATERIAL				NOB, MODIFIED
SYM	DESCRIPTION	DATE	CH. NO.	DRAFTS	CHECKER	ENG. APP.	
UNLESS OTHERWISE SPECIFIED DIMENSIONS ARE IN INCHES AND INCLUDE CHEMICALLY APPLIED OR PLATED FINISHES			SCALE				
DECIMALS .X ± .05 .XX ± .01 .XXX ± .005	TOLERANCES	FRACTIONS ± 1/64 ANGLES ± 0° 30'	CODE C	S401-155			
TYPE & TEMPER		HEAT TREAT. SPEC.	DRAWN	CHECKED	FINAL APPROVAL		
			ATURSI	aa gcs	RJC 3-30-64		
FINISH & SPEC. NO.		ELEC. DES. APP.	MECH. DES. APP.		MP-128 0		