

REQ. PER UNIT	USED ON			LD-962
	MODEL	ASSY. NO.	DATE	
1	GPE-1		8-5-61	

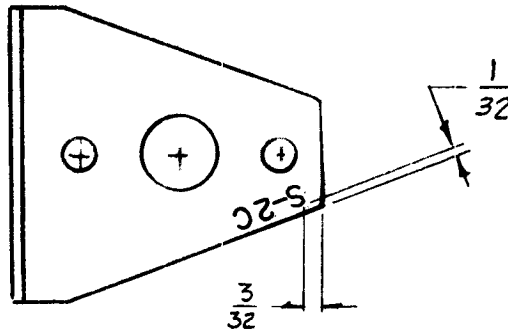

ALL LETTERING $\frac{1}{8}$ " HIGH
 BLACK GOTHIC,
 MARKING PROCESS: AS PER TMC SPECIFICATION S-727

REF-TMC DWG. NO. (1) MS-2638

ISSUE	ITEM	CHANGED FROM	DATE	CH. NO.	DRAFTS	CHECKER	ENG. APP.	REQ.	ITEM	PART NO.	DESCRIPTION	SYMBOL					
											THE TECHNICAL MATERIEL CORP. MAMARONECK, NEW YORK LETTERING, SWITCH BRACKET						
TOLERANCES			SCALE:														
DEC. DIM. ±			MAXIMUM ALLOWABLE TOLERANCES HAVE BEEN DETERMINED AND ANY DEVIATIONS WILL BE CAUSE FOR REJECTION. REMOVE ALL BURRS AND SHARP EDGES					TYPE & TEMPER		HEATTREAT. SPEC.		DRAWN		CHECKED		FINAL APPROVAL	
FRAC. DIM. ±								FINISH & SPEC. NO.		ELEC. DES. APP.		MECH. DES. APP.		LD-962			
ANGULAR DIM. ±																	