

5

4

3

2

1

| REVISIONS |     |                  |          |          |       |      |      |
|-----------|-----|------------------|----------|----------|-------|------|------|
| ZONE      | LTR | DESCRIPTION      | DATE     | E.M.N.NO | DRAFT | CHKD | APPD |
|           | X   | EXP. RELEASE     | 10/28/69 |          | K.H.  |      |      |
|           | Ø   | ORIGINAL RELEASE | 1/6/70   |          | W     |      |      |

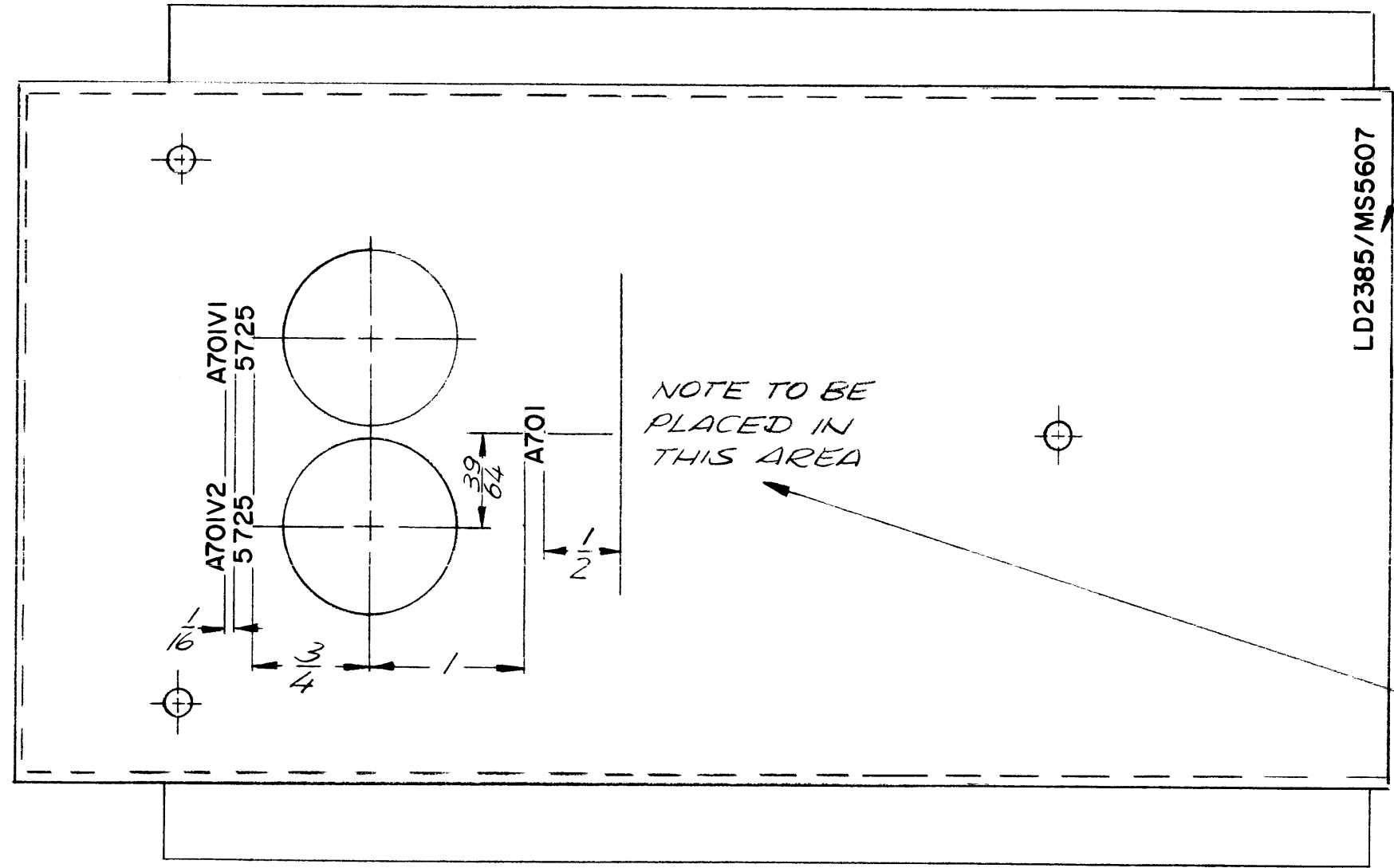

MARK TMC PART NUMBER  
1/8 HIGH GOTHIC WITH LATEST  
REVISION LETTER

PARTIAL REFERENCE DESIGNATIONS  
ARE SHOWN. PREFIX THE PART DESIGNATION  
WITH THE SUBASSEMBLY DESIGNATION.

NOTE TO BE  
PLACED IN  
THIS AREA

LD2385/MS5607

UNLESS OTHERWISE SPECIFIED:

MARKING PROCESS: AS PER TMC SPECIFICATION S727

LETTERING: 1/8 HIGH BLACK GOTHIC, LOCATED AS SHOWN

REF.: MS5607

| REQ'D  | ITEM            | PART NUMBER | DESCRIPTION | SYM. |
|--|-----------------|-------------|-------------|------|
| LIST OF MATERIAL                                     |                 |             |             |      |
| THE TECHNICAL MATERIEL CORP.<br>MAMARONECK, NEW YORK |                 |             |             |      |
| MARKING, PA SENSE COVER                              |                 |             |             |      |
| SIZE   | CODE IDENT. NO. | DWG NO.     | ISSUE       |      |
| B  | 82679           | LD 2385     | Ø           |      |
| SCALE  | 1:1             |             | SHEET OF    |      |

| 1          | PALA - 10K    | AX 5084   |
|------------|---------------|-----------|
| QTY / UNIT | MODEL USED ON | ASS'Y NO. |

| APPLICATION |  |
|-------------|--|
| CODE        |  |

**NOTICE TO PERSONS RECEIVING THIS DRAWING**  
THE TECHNICAL MATERIEL CORPORATION claims proprietary right in the material disclosed hereon. This drawing is issued in confidence for engineering information only and may not be reproduced or used to manufacture anything shown hereon without permission from THE TECHNICAL MATERIEL CORPORATION to the user. This drawing is loaned for mutual assistance and is subject to recall at any time.

UNLESS OTHERWISE SPECIFIED  
DIMENSIONS ARE IN INCHES  
AND INCLUDE CHEMICALLY APPLIED  
OR PLATED FINISHES

|             |              |
|-------------|--------------|
| DECIMALS    | FRACTIONS    |
| .X ± .05    | 1/64         |
| .XX ± .01   | TOLS. ANGLES |
| .XXX ± .005 | 0° - 30'     |

MATERIAL

FINISH

|                    |           |
|--------------------|-----------|
| FINAL APPROVAL     | DATE      |
| <i>[Signature]</i> | 26 JAN 70 |
| MECH. DES.         | DATE      |
| <i>[Signature]</i> |           |
| ELECT. DES.        | DATE      |
|                    |           |
| CHECKED            | DATE      |
|                    |           |
| DRAWN              | DATE      |
| <i>[Signature]</i> | 10/28/69  |

5

4

3

2

1