

5

4

3

2

1

REVISIONS						
ZONE	LTR	DESCRIPTION	DATE	E.M.N.NO	DRAFT	CHKD APPD
	X	EXP. RELEASE	1/9/68	+	HG	<i>[Signature]</i>
	<i>[Signature]</i>	ORIGINAL RELEASE	8/8/67	<i>[Signature]</i>		

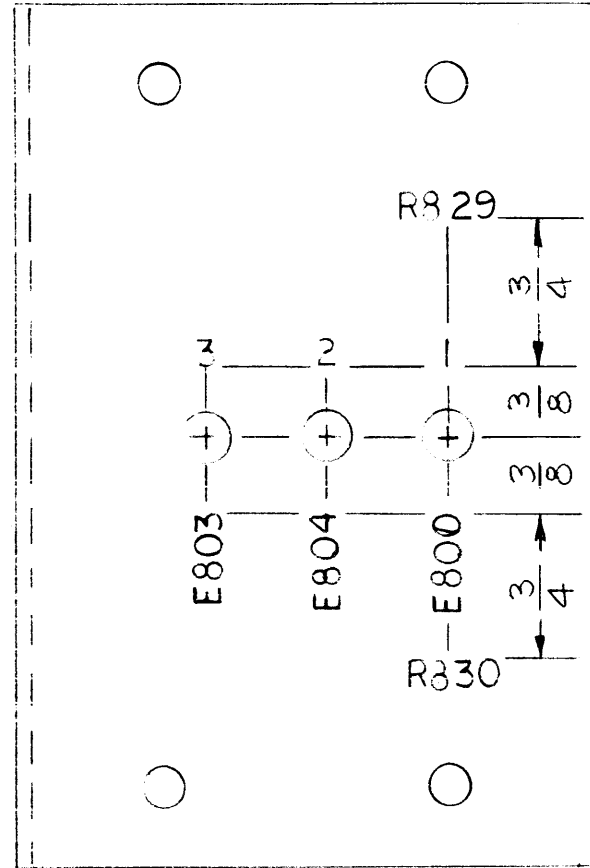

MARK TMC P/N
 1/8 HIGH GOTHIC
 W/LATEST REV.
 LETTER.

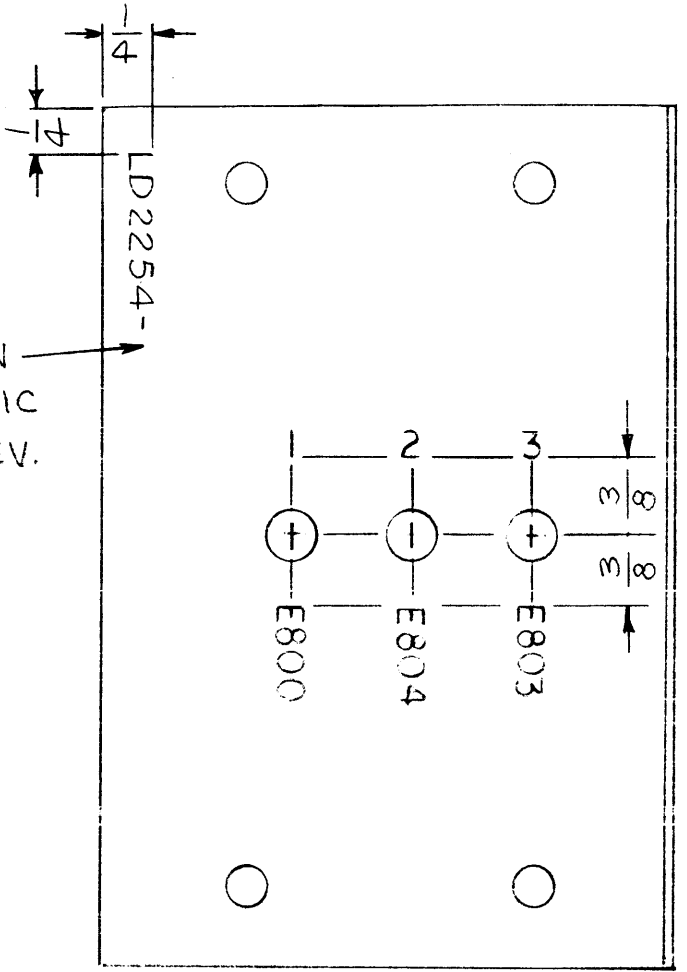

MARKING PROCESS: AS PER TMC SPECIFICATION S-727.
 LETTERING: 1/8 HIGH BLACK GOTHIC, LOCATED AS SHOWN.

RF: MS5195-1

REQ'D	ITEM	PART NUMBER	DESCRIPTION	SYM.
	F. BUDETTI		LIST OF MATERIAL	
<p>FINAL APPROVAL <i>[Signature]</i> DATE 8/8/69</p> <p>MECH. DES. <i>[Signature]</i> DATE</p> <p>ELECT. DES. DATE</p> <p>CHECKED DATE</p> <p>DRAWN <i>[Signature]</i> DATE 8/8/69</p>				
<p>THE TECHNICAL MATERIEL CORP. MAMARONECK, NEW YORK</p>				
MARKING, PLATE, SIDE RIGHT				
SIZE	CODE IDENT. NO.	DWG NO.	ISSUE	
B	82679	LD 2254	<i>[Signature]</i>	
SCALE	1:1	SHEET	OF	

QTY / UNIT	MODEL USED ON	ASS'Y NO.
	GPT-10KLF E	
APPLICATION		
CODE	S401-451	
A		

NOTICE TO PERSONS RECEIVING THIS DRAWING
 THE TECHNICAL MATERIEL CORPORATION claims proprietary right in the material disclosed hereon. This drawing is issued in confidence for engineering information only and may not be reproduced or used to manufacture anything shown hereon without permission from THE TECHNICAL MATERIEL CORPORATION to the user. This drawing is loaned for mutual assistance and is subject to recall at any time.

UNLESS OTHERWISE SPECIFIED
 DIMENSIONS ARE IN INCHES
 AND INCLUDE CHEMICALLY APPLIED
 OR PLATED FINISHES

DECIMALS	FRACTIONS
.X ± .05	1/64
.XX ± .01	TOLS. ANGLES
.XXX ± .005	0° -30'

MATERIAL

FINISH

5

4

3

2

1