

MARKING PROCESS: AS PER TMC SPECIFICATION S-727.
 LETTERING: 1/8 HIGH BLACK GOTHIC, LOCATED AS SHOWN.

REVISIONS					
ZONE	SYM	DESCRIPTION	DATE	E.M.N. NO.	APPD
	X1	PICTORIAL CLARIFIED	9-10-65	X1	C.D.L.
	Ø	ORIGINAL RELEASE FOR PRODUCTION	10/26/65	Ø	/10

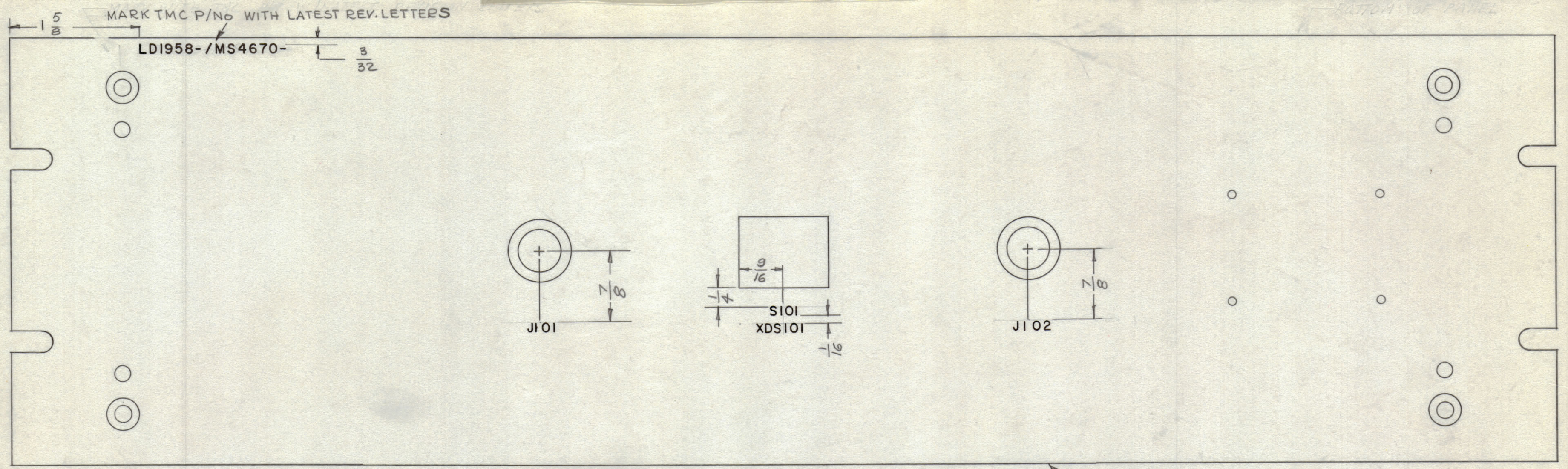

MARKING - REAR VIEW TOP OF PANEL

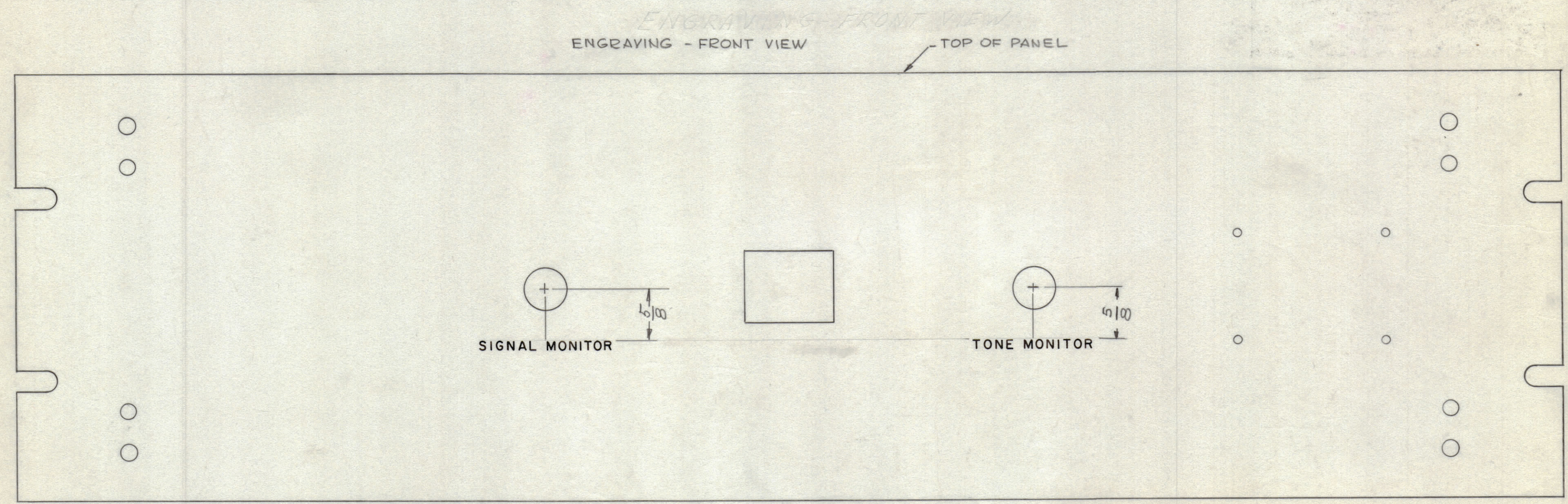

ENGRAVING - FRONT VIEW TOP OF PANEL

HEIGHT OF LETTERS	DEPTH OF STROKE	WIDTH OF STROKE
1/8	.010	.020

UNLESS OTHERWISE SPECIFIED - ALL LETTERING TO BE WHITE FILLED, ENGRAVING TO BE GOTHIC WHITE FILLED SIZE SHOWN ON CHART ENGRAVING PROCESS AS PER TMC SPEC. S-566

NOTES

1	RARB-1	AS125
QTY./UNIT	MODEL USED ON	ASSY. NO.
SCALE 1:1	CODE A	

THE CONTENTS OF THIS DRAWING ARE THE EXCLUSIVE PROPERTY OF THE TECHNICAL MATERIEL CORP. ITS UNAUTHORIZED USE OR REPRODUCTION IN WHOLE OR IN PART IS STRICTLY FORBIDDEN.

REF: MS 4670

REQ'D.	ITEM	PART NUMBER	DESCRIPTION	SYMBOL
LANGER LIST OF MATERIAL				
MATERIAL THE TECHNICAL MATERIEL CORP. MAMARONECK, NEW YORK				
FINISH TITLE MARKING, FRONT PANEL				
UNLESS OTHERWISE SPECIFIED DIMENSIONS ARE IN INCHES AND INCLUDE CHEMICALLY APPLIED OR PLATED FINISHES		DRAWN	DATE	FINAL APPROVAL
DECIMALS .X ± .05 .XX ± .01 .XXX ± .005		CHECKED	DATE	DATE
FRACTIONS ± 1/64 ANGLES ± 0° 30'		ELECT. DES.	DATE	DATE
TOLERANCES		MECH. DES.	DATE	DATE
SHEET				REV. LTR.

LD 1958