

REQ. PER UNIT	USED ON			LD1817	Ø
	MODEL	ASS'Y. NO.	DATE		
1	AFCR-3		3-23-65		

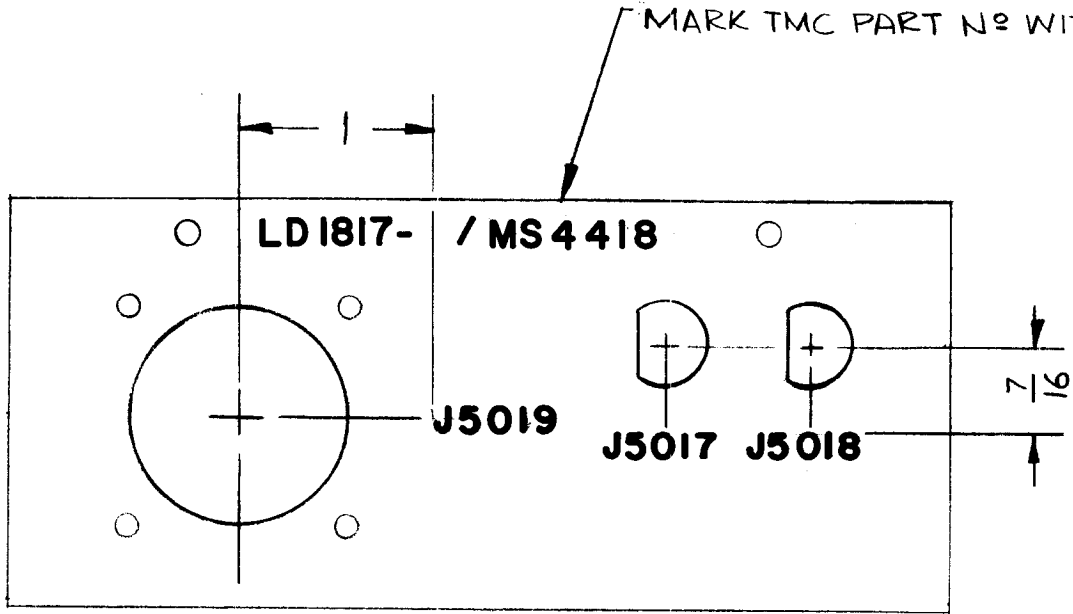

NOTE:  
FOR CLARITY, ONLY HOLES PERTAINING TO MARKINGS ARE SHOWN.

— FRONT VIEW — MARKING PROCESS: AS PER TMC SPECIFICATION S-727.  
LETTERING: 1/8 HIGH BLACK GOTHIC, LUSTERLESS  
LOCATED AS SHOWN.

(REF MS4418)

							REQ. ITEM	PART NO.	DESCRIPTION			SYMBOL
ORIGINAL RELEASED FOR									THE TECHNICAL MATERIEL CORP. MAMARONECK, NEW YORK			
Ø		3-25-65	2	RU	<del>RU</del>		STOCK SIZE			MARKING, REAR PLATE		
X	EXP. RELEASE	3-23-65	1	CL	<del>RU</del>		MATERIAL					
SYM	DESCRIPTION	DATE	CH. NO.	DRAFTS	CHECKER	ENG. APP.				C. LANZA	<del>CL</del>	<del>CL</del>
UNLESS OTHERWISE SPECIFIED DIMENSIONS ARE IN INCHES AND INCLUDE CHEMICALLY APPLIED OR PLATED FINISHES						SCALE				DRAWN	CHECKED	FINAL APPROVAL
						Do Not Scale						
DECIMALS	TOLERANCES	FRACTIONS	CODE				TYPE & TEMPER		HEAT TREAT. SPEC.			
.X ± .05		± 1/64								LD1817		Ø
.XX ± .01		ANGLES										
.XXX ± .005		± 0° 30'										
							FINISH & SPEC. NO.		ELEC. DES. APP.		MECH. DES. APP.	