

LD1603

REVISIONS

SYM	DESCRIPTION	DATE	E.M.N. NO.	DRAFT	CHKD	APPD
X	EXPERIMENTAL RELEASE	9.11.64		MB		
Ø	ORIGINAL RELEASE FOR PRODUCTION	9.28.64	Ø	92		

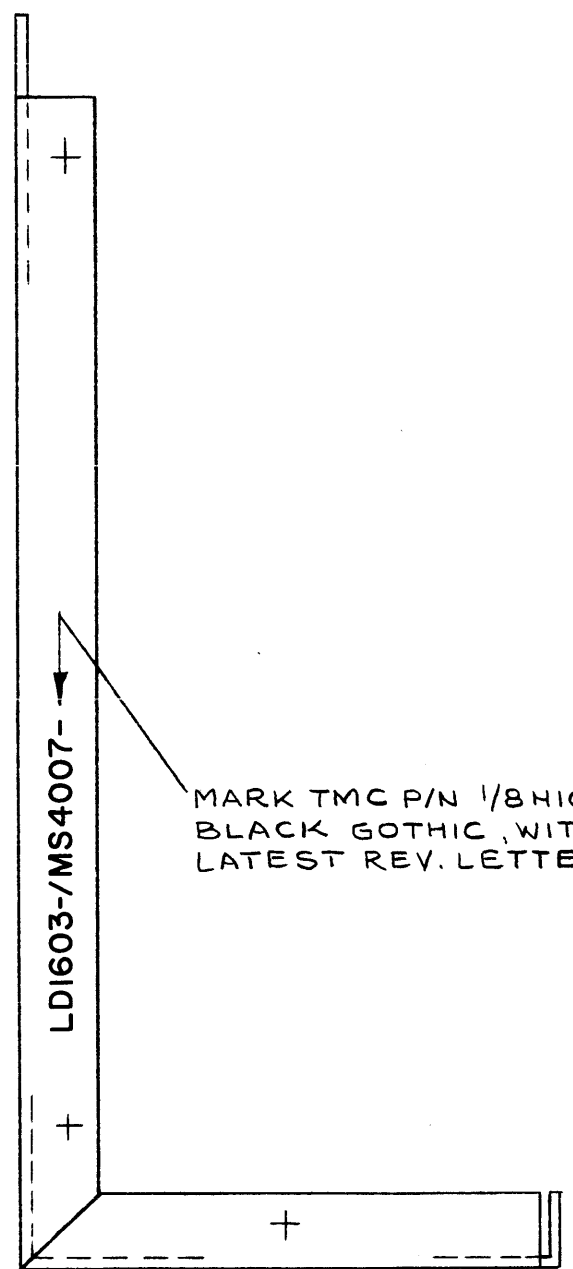
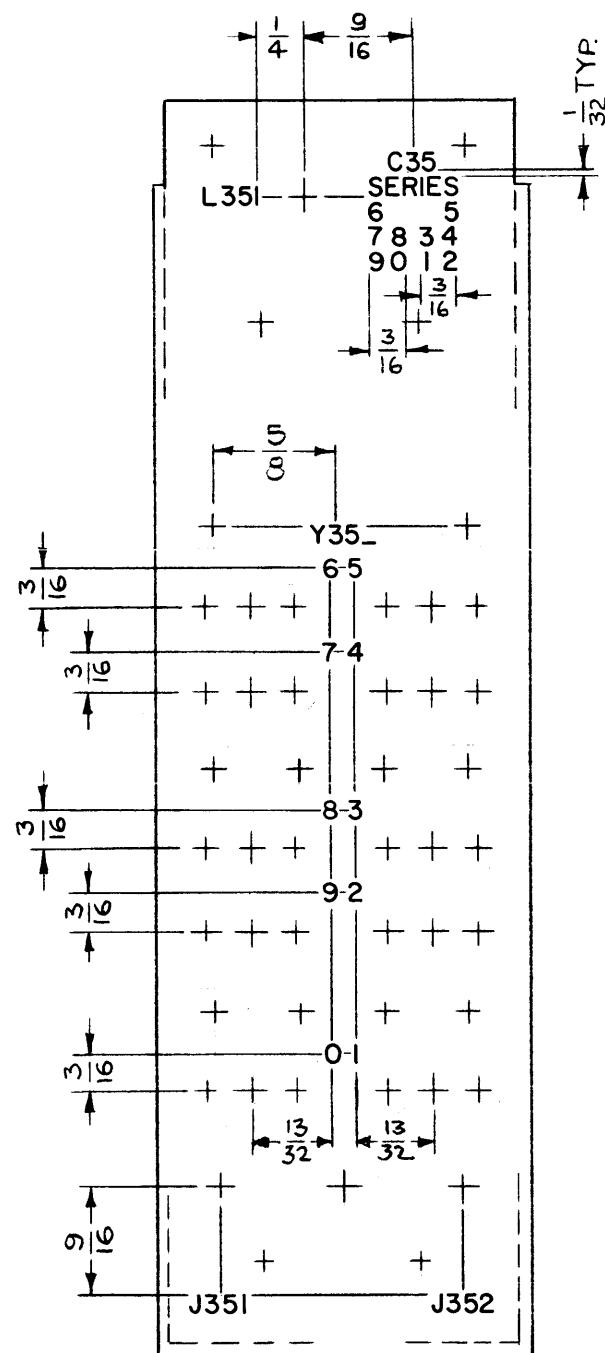

- ~ UNLESS OTHERWISE SPECIFIED ~
1. - ALL LETTERING TO BE 3/32 HIGH BLACK GOTHIC
  2. - MARKING PROCESS: AS PER TMC S-727
  3. - ALL LETTER GROUPS TO BE CENTERED ON HOLES

REF.: MS 4007

REQ'D.	ITEM	PART NUMBER	DESCRIPTION	SYMBOL
<b>GELLMAN LIST OF MATERIAL</b>				
MATERIAL		<b>THE TECHNICAL MATERIEL CORP. MAMARONECK, NEW YORK</b>		
FINISH		TITLE MARKING, CHASSIS, (SPECTRUM FILTER) MARKING METHOD, PER TMC S-727		
UNLESS OTHERWISE SPECIFIED DIMENSIONS ARE IN INCHES AND INCLUDE CHEMICALLY APPLIED OR PLATED FINISHES		DRAWN MB	DATE 9.11.64	FINAL APPROVAL
		CHECKED	DATE 9.14.64	
DECIMALS .X ± .05 .XX ± .01 .XXX ± .05		ELECT. DES.	DATE	<b>LD1603</b>
FRACTIONS ± 1/64 ANGLES ± 0° 30'		MECH. DES.	DATE 9.14.64	
			SHEET	REV. LTR. Ø

1	LFSB-1	
Q'TY./UNIT	MODEL USED ON	ASS'Y. NO.
SCALE 1:1	CODE A	
THE CONTENTS OF THIS DRAWING ARE THE EXCLUSIVE PROPERTY OF THE TECHNICAL MATERIEL CORP. ITS UNAUTHORIZED USE OR REPRODUCTION IN WHOLE OR IN PART IS STRICTLY FORBIDDEN.		

NOTES

LD1606 A

REVISIONS

SYM	DESCRIPTION	DATE	E.M.N. NO.	DRAFT	CHKD	APPD
Q	ORIGINAL RELEASE FOR PRODUCTION	12-8-64	Q	<i>[Signature]</i>		
A	2 HOLES RELOCATED	12-23-64	13157	<i>[Signature]</i>	<i>[Signature]</i>	

MARKING PROCESS: AS PER TMC SPECIFICATION S-727.  
 LETTERING: 1/8 HIGH BLACK GOTHIC, LOCATED AS SHOWN.

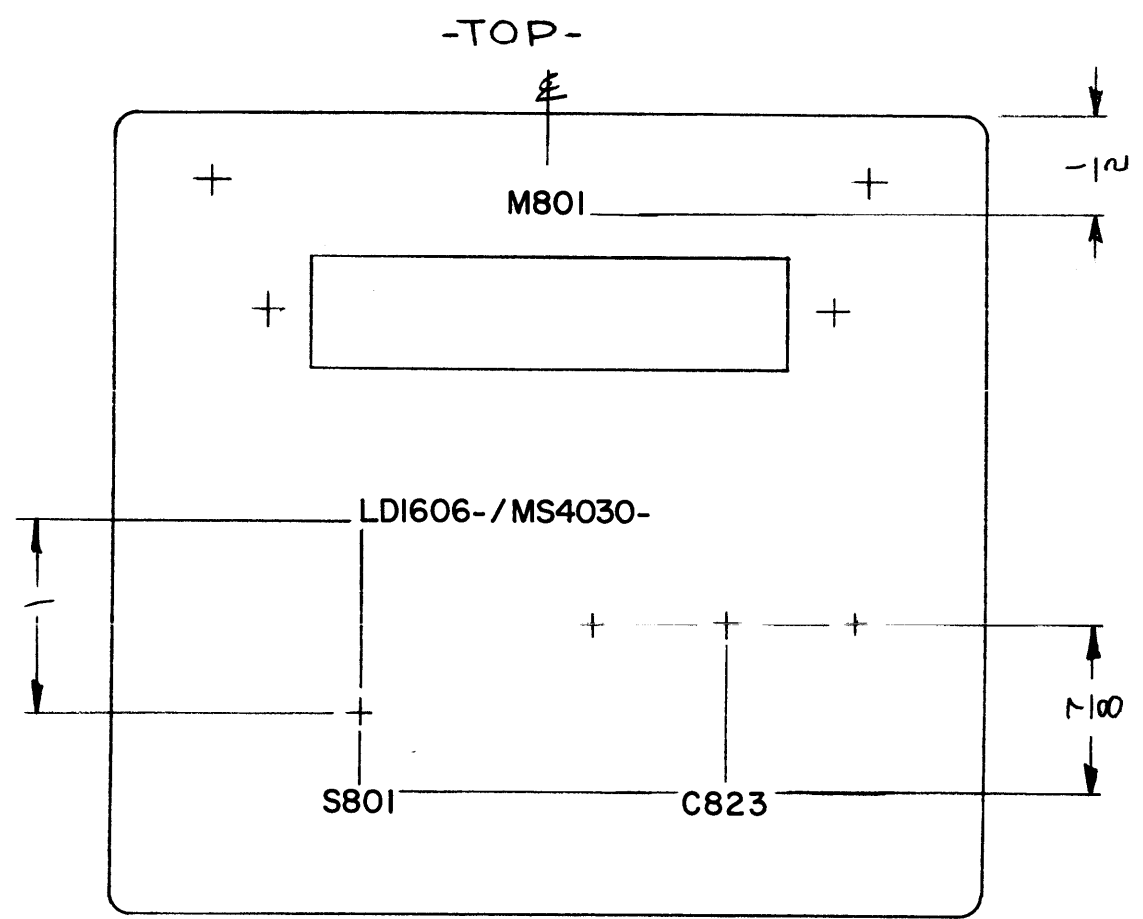
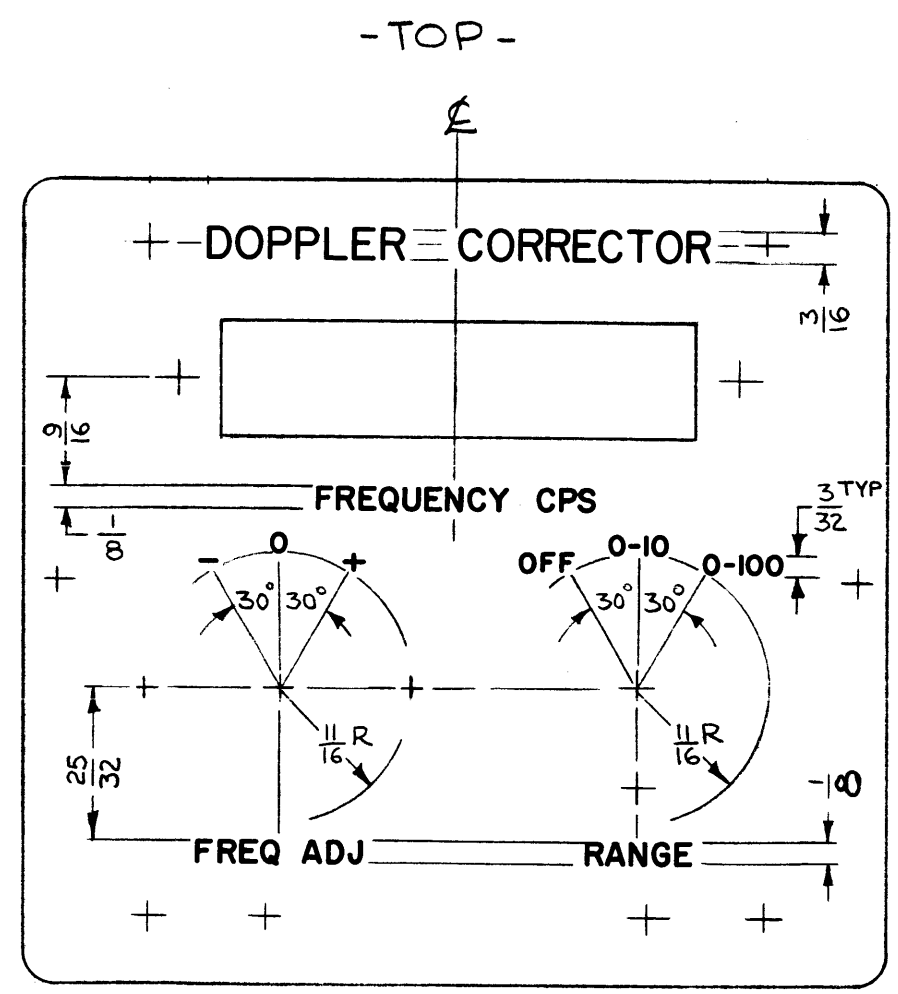

- FRONT -

- REAR -

REF: MS4030 (1)

HEIGHT OF LETTERS	DEPTH OF STROKE	WIDTH OF STROKE
3/32	.010	.015
1/8	.010	.020
3/16	.010	.025

NOTE:  
 1. ENGRAVING TO BE GOTHIC WHITE FILLED SIZE SHOWN ON CHART.  
 2. ALL LETTER GROUPS TO BE CENTERED ON HOLES

1	PFCB-1	
QTY./UNIT	MODEL USED ON	ASS'Y. NO.
SCALE 1:1	CODE A	

THE CONTENTS OF THIS DRAWING ARE THE EXCLUSIVE PROPERTY OF THE TECHNICAL MATERIEL CORP. ITS UNAUTHORIZED USE OR REPRODUCTION IN WHOLE OR IN PART IS STRICTLY FORBIDDEN.

REQ'D.	ITEM	PART NUMBER	DESCRIPTION	SYMBOL
O. POSE LIST OF MATERIAL				
MATERIAL			THE TECHNICAL MATERIEL CORP. MAMARONECK, NEW YORK	
FINISH			TITLE MARKING, PANEL FRONT MARKING PROCESS: MARKING & ENGRAVING	
UNLESS OTHERWISE SPECIFIED DIMENSIONS ARE IN INCHES AND INCLUDE CHEMICALLY APPLIED OR PLATED FINISHES		DRAWN <i>[Signature]</i>	DATE 10-11-64	FINAL APPROVAL <i>[Signature]</i>
DECIMALS .X ± .05 .XX ± .01 .XXX ± .005		CHECKED <i>[Signature]</i>	DATE 12-9-64	
FRACTIONS ± 1/64 ANGLES ± 0° 30'		ELECT. DES. <i>[Signature]</i>	DATE	
TOLERANCES		MECH. DES.	DATE	
			SHEET	REV. LTR.
			LD1606	A

NOTES

LD1608

REVISIONS						
SYM	DESCRIPTION	DATE	FMN NO	DRAFT	CHKD	APPD
X	EXP. RELEASE	9-19-64		G.D.L.		
Ø	ORIGINAL RELEASE FOR PRODUCTION	9-24-64	Ø	J.F.		

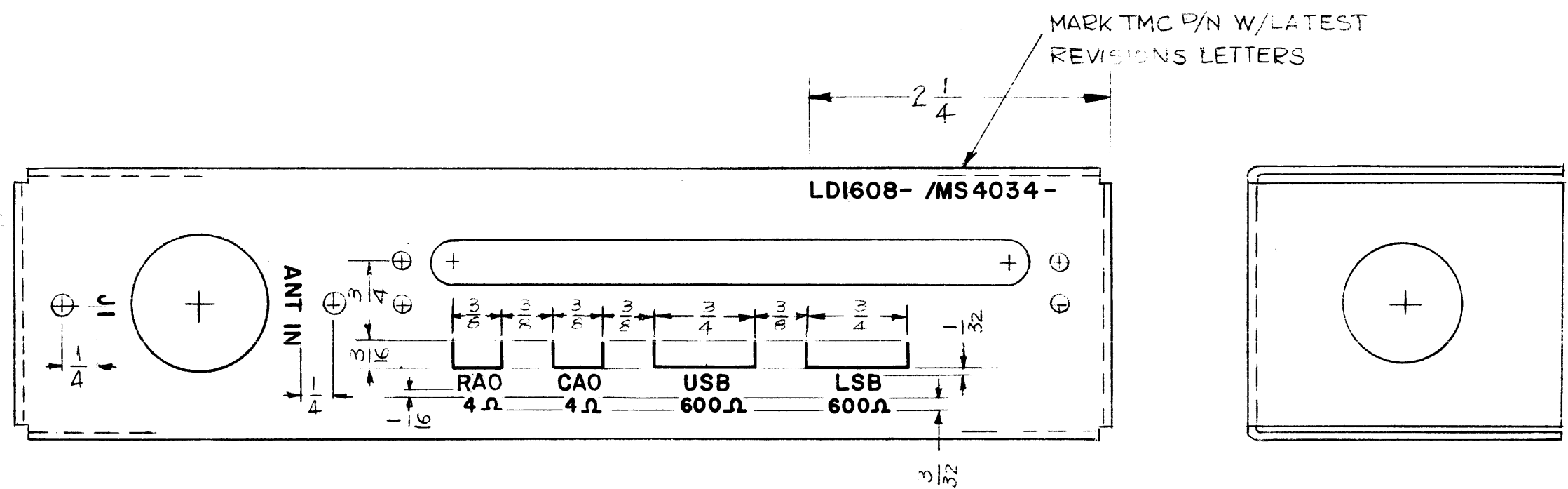

—UNLESS OTHERWISE SPECIFIED—

LETTERING: 1/8 HIGH BLACK GOTHIC, LOCATED AS SHOWN  
 LINES TO BE BLACK, .015 WIDTH.  
 MARKING PROCESS: AS PER TMC SPEC. S-727

REF - MS 4034

1	RAK21B-1	A3340
Q'TY./UNIT	MODEL USED ON	ASS'Y. NO.
SCALE 1:1	CODE A	

NOTES

THE CONTENTS OF THIS DRAWING ARE THE EXCLUSIVE PROPERTY OF THE TECHNICAL MATERIEL CORP. ITS UNAUTHORIZED USE OR REPRODUCTION IN WHOLE OR IN PART IS STRICTLY FORBIDDEN.

REQ'D.	ITEM	PART NUMBER	DESCRIPTION	SYMBOL
M. STURMER LIST OF MATERIAL				
MATERIAL		#	THE TECHNICAL MATERIEL CORP. MAMARONECK, NEW YORK	
FINISH		#	TITLE MARKING, CHASSIS OUTPUT MARKING PROCESS AS PER TMC SPEC S727	
UNLESS OTHERWISE SPECIFIED DIMENSIONS ARE IN INCHES AND INCLUDE CHEMICALLY APPLIED OR PLATED FINISHES			DRAWN G.D.L. DATE 9-21-64	FINAL APPROVAL DATE
DECIMALS .X ± .05 .XX ± .01 .XXX ± .005			CHECKED @ DATE 9-23-64	DATE
FRACTIONS ± 1/64 ANGLES ± 0° 30'			ELECT. DES. DATE	DATE
TOLERANCES			MECH. DES. DATE 9-24-64	DATE
LD1608				Ø
SHEET				REV. LTR.

LD1612

REVISIONS						
SYM	DESCRIPTION	DATE	E.M.N. NO.	DRAFT	CHKD	APPD
X	EXPERIMENTAL RELEASE	9-23-64	X	SRG		
Ø	ORIGINAL RELEASE FOR PRODUCTION	9-28-64	Ø	RL		

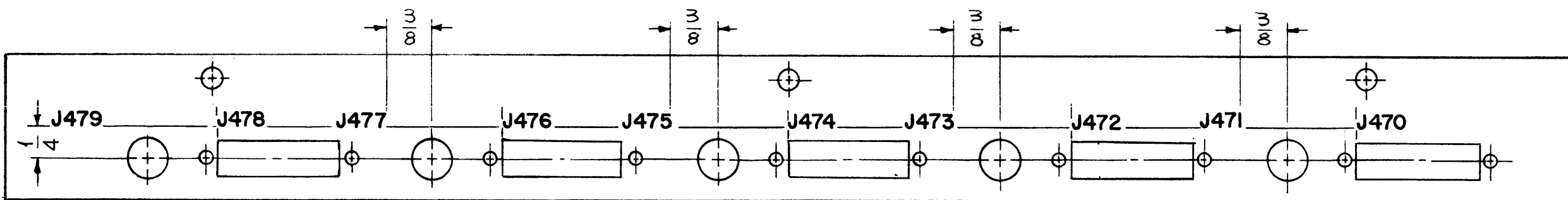

FRONT VIEW

MARK TMC PART NO.  
LD1612- /MS3999- WITH  
LATEST REV. LETTER  
(ON REAR OF BRACKET)

MARKING PROCESS: AS PER TMC SPECIFICATION S-727.  
LETTERING: 1/8 HIGH BLACK GOTHIC, LOCATED AS SHOWN.

REF: MS3999

REQ'D.	ITEM	PART NUMBER	DESCRIPTION	SYMBOL
M. GELLMAN LIST OF MATERIAL				
MATERIAL		THE TECHNICAL MATERIEL CORP. MAMARONECK, NEW YORK		
FINISH		TITLE MARKING BRACKET, MTG. CONNECTORS, (MAIN CHASIS) MARKING PROCESS: AS PER TMC SPEC S-727		
UNLESS OTHERWISE SPECIFIED DIMENSIONS ARE IN INCHES AND INCLUDE CHEMICALLY APPLIED OR PLATED FINISHES		DRAWN	DATE	FINAL APPROVAL
		SRG	9-23-64	<i>[Signature]</i>
		CHECKED	DATE	
		<i>[Signature]</i>	9-28-64	
		ELECT. DES.	DATE	
		MECH. DES.	DATE	
		<i>[Signature]</i>	9-28-64	

1	LFSB-1	
Q'TY./UNIT	MODEL USED ON	ASS'Y. NO.
SCALE 1:1	CODE A	---
THE CONTENTS OF THIS DRAWING ARE THE EXCLUSIVE PROPERTY OF THE TECHNICAL MATERIEL CORP. ITS UNAUTHORIZED USE OR REPRODUCTION IN WHOLE OR IN PART IS STRICTLY FORBIDDEN.		

NOTES

LD1617

REVISIONS

SYM	DESCRIPTION	DATE	E.M.N. NO.	DRAFT	CHKD	APPD
X	EXPERIMENTAL RELEASE	9-28-64	X	SRG	J.M.	
Ø	ORIGINAL RELEASE FOR PRODUCTION	2-10-65	Ø	J.F.	JCB	

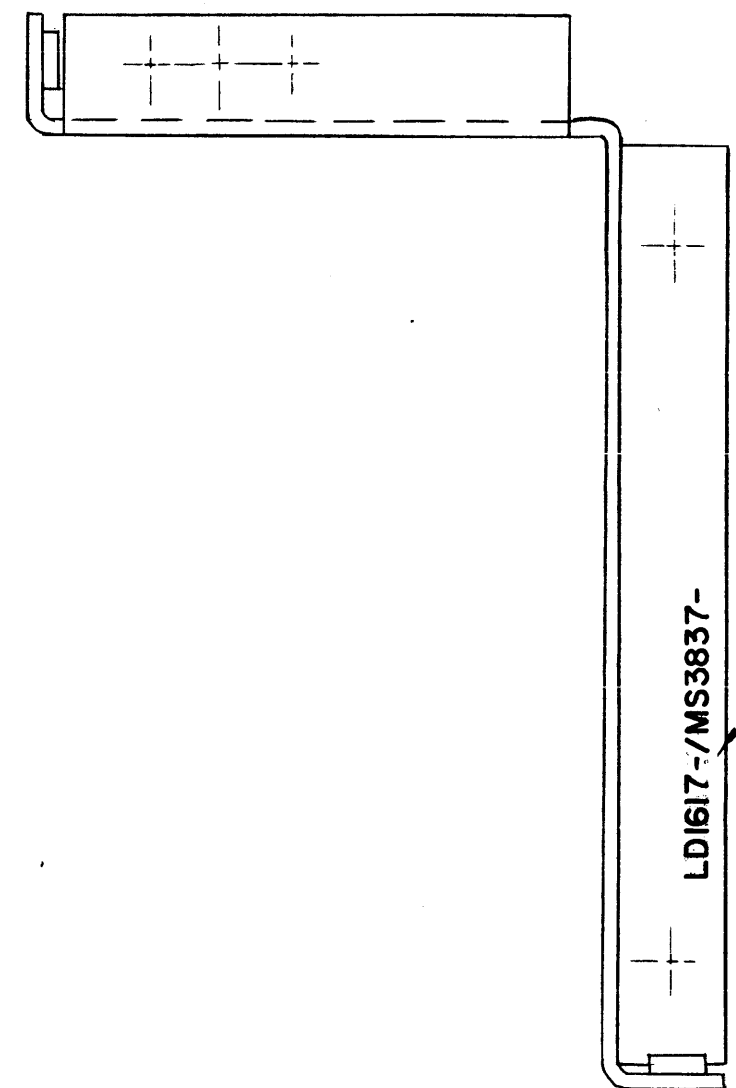
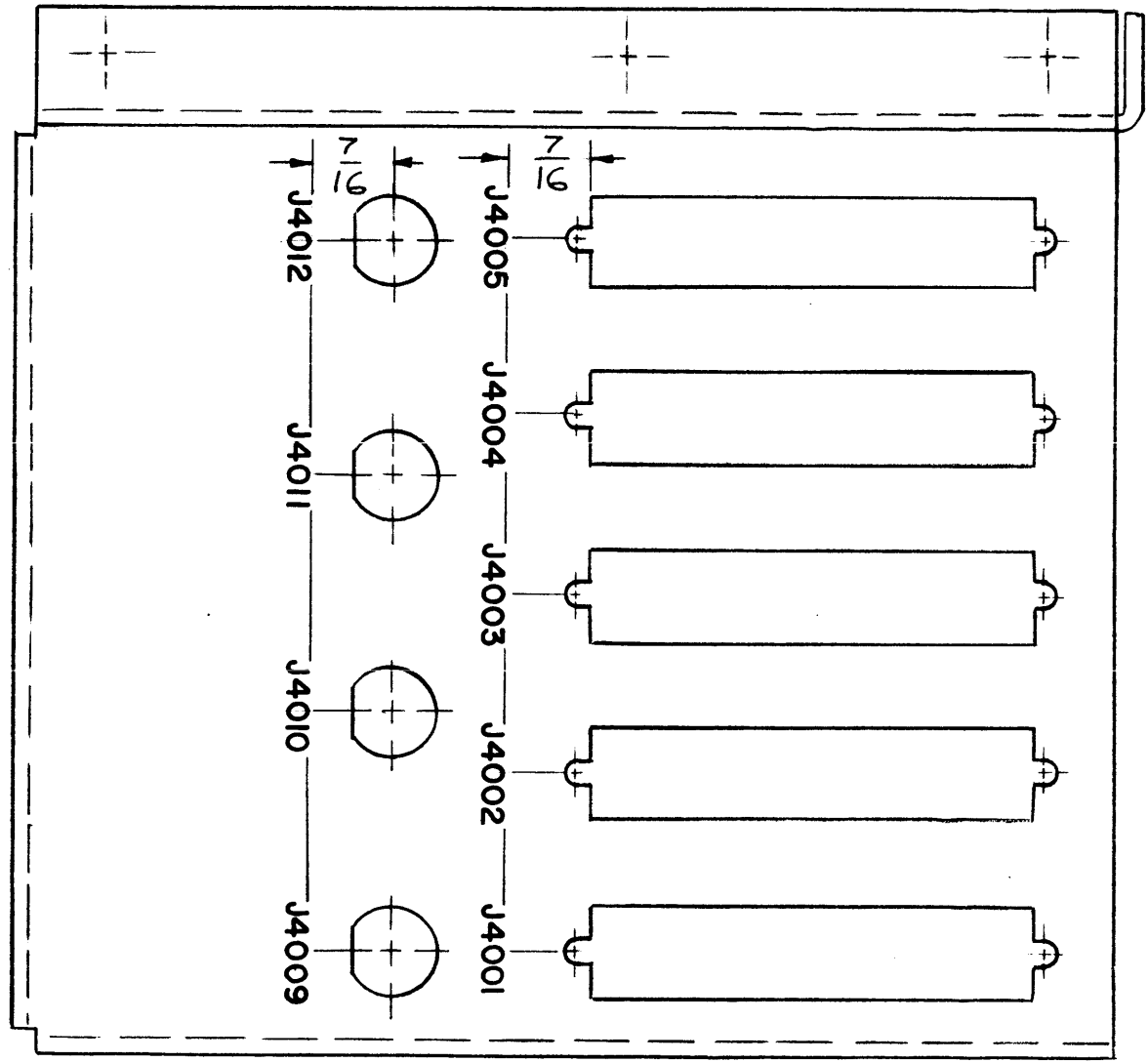

MARK TMC PART NO. W/LATEST REV. LETTER.

MARKING PROCESS: AS PER TMC SPECIFICATION S-727.  
 LETTERING: 1/8 HIGH BLACK GOTHIC, LOCATED AS SHOWN.

REF: MS3837

REQ'D.	ITEM	PART NUMBER	DESCRIPTION	SYMBOL
	F. EATON		LIST OF MATERIAL	
	MATERIAL		THE TECHNICAL MATERIEL CORP. MAMARONECK, NEW YORK	
	FINISH		TITLE: MARKING, BRACKET, MTG. CONNECTOR MARKING PROCESS: AS PER TMC SPEC 5727	
	UNLESS OTHERWISE SPECIFIED DIMENSIONS ARE IN INCHES AND INCLUDE CHEMICALLY APPLIED OR PLATED FINISHES		DRAWN SRG DATE 9-28-64	FIRM APPROVAL DATE
	DECIMALS .X ± .05 .XX ± .01 .XXX ± .005	FRACTIONS ± 1/64 ANGLES ± 0° 30'	CHECKED JCB DATE 2/9/65	DATE
	TOLERANCES		ELECT. DES. DATE 2/8/65	LD1617
			MECH. DES. W. JORDAN DATE 2/8/65	Ø

1	RTTD-1	A3705
Q'TY./UNIT	MODEL USED ON	ASS'Y. NO.
SCALE 1:1	CODE A	#
THE CONTENTS OF THIS DRAWING ARE THE EXCLUSIVE PROPERTY OF THE TECHNICAL MATERIEL CORP. ITS UNAUTHORIZED USE OR REPRODUCTION IN WHOLE OR IN PART IS STRICTLY FORBIDDEN.		

NOTES

MARK TMC P/No.W/LATEST REVISION LETTER

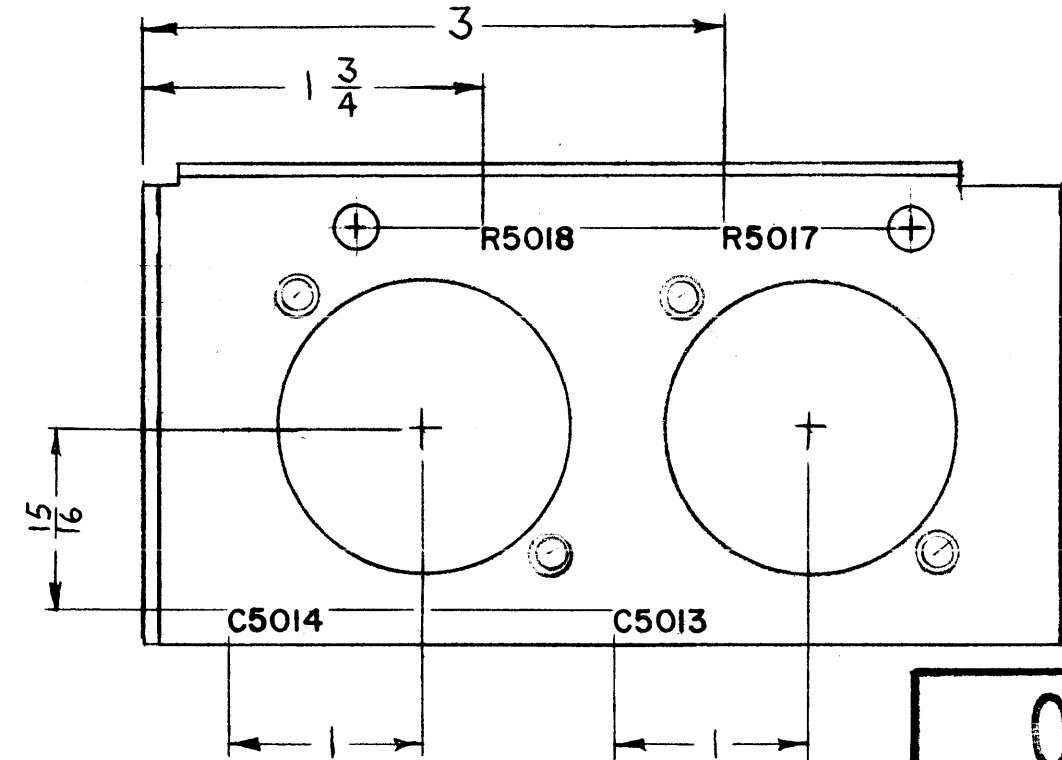
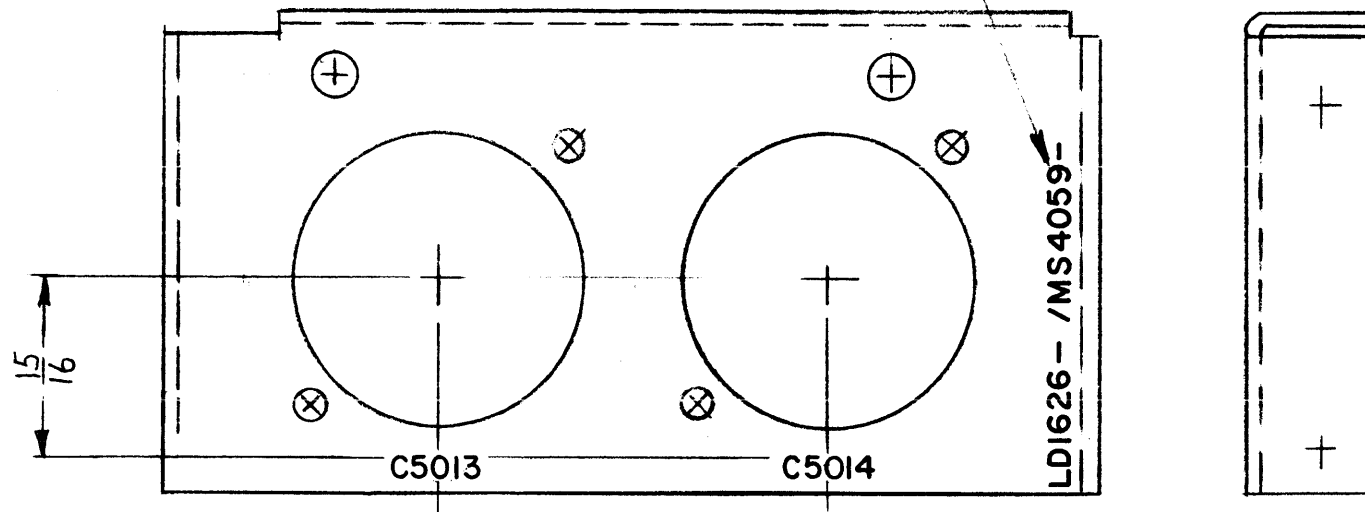

**OBSOLETE**  
 NO LONGER USED  
 PER EMN. # 13608 3/16/65  
 97.

LD1626 B

REVISIONS					
SYM	DESCRIPTION	DATE	E.M.N. NO.	DRAFT	CHKD APPD
X	EXP. RELEASE	10-8-64		G.D.L.	
Ø	ORIGINAL RELEASE FOR PRODUCTION	10-9-64		@	
A	C5013 & C5014 RELOC. ON FRONT & REAR VIEW; R5018 & R5017 RELOC. SEE (MS4059) REV. "A".	1-18-65	12776	97	NL
B	OBSOLETE NOTE ADD.	3-16-65	13608	97	

MARKING PROCESS: AS PER TMC SPECIFICATION S-727.

LETTERING: 1/8 HIGH BLACK GOTHIC, LOCATED AS SHOWN.

REF: MS 4059

RTMU-1		ASS'Y. NO.
Q'TY./UNIT	MODEL USED ON	
SCALE 1:1	CODE A	

NOTES

THE CONTENTS OF THIS DRAWING ARE THE EXCLUSIVE PROPERTY OF THE TECHNICAL MATERIEL CORP. ITS UNAUTHORIZED USE OR REPRODUCTION IN WHOLE OR IN PART IS STRICTLY FORBIDDEN.

REQ'D.	ITEM	PART NUMBER	DESCRIPTION	SYMBOL
<b>EATON LIST OF MATERIAL</b>				
MATERIAL		THE TECHNICAL MATERIEL CORP. MAMARONECK, NEW YORK		
FINISH		TITLE MARKING PLATE, MTG CAPACITOR MARKING PROCESS: AS PER TMC SPEC. S727		
UNLESS OTHERWISE SPECIFIED DIMENSIONS ARE IN INCHES AND INCLUDE CHEMICALLY APPLIED OR PLATED FINISHES		DRAWN G.D.L.	DATE 10-8-64	FINAL APPROVAL
DECIMALS .X ± .05 .XX ± .01 .XXX ± .005		CHECKED @	DATE 10-9-64	DATE
FRACTIONS ± 1/64 ANGLES ± 0° 30'		ELECT. DES. <i>[Signature]</i>	DATE 10-9-64	DATE
TOLERANCES		MECH. DES.	DATE	DATE
			LD1626	B
			SHEET	REV. LTR.

REVISIONS						
SYM	DESCRIPTION	DATE	E.M.N. NO.	DRAFT	CHKD	APPD
X	EXP. RELEASE	10-17-64	X	SRG		
X1	ADDED A3985 TO Z5020 PT. NO.	11/11/64	X1	JL	J.M.	W.J.
Ø	ORIGINAL RELEASE FOR PRODUCTION	1-16-65	Ø		J.M.	

LD1629

MARK TMC PART NO.  
W/LATEST REV.  
LETTER.

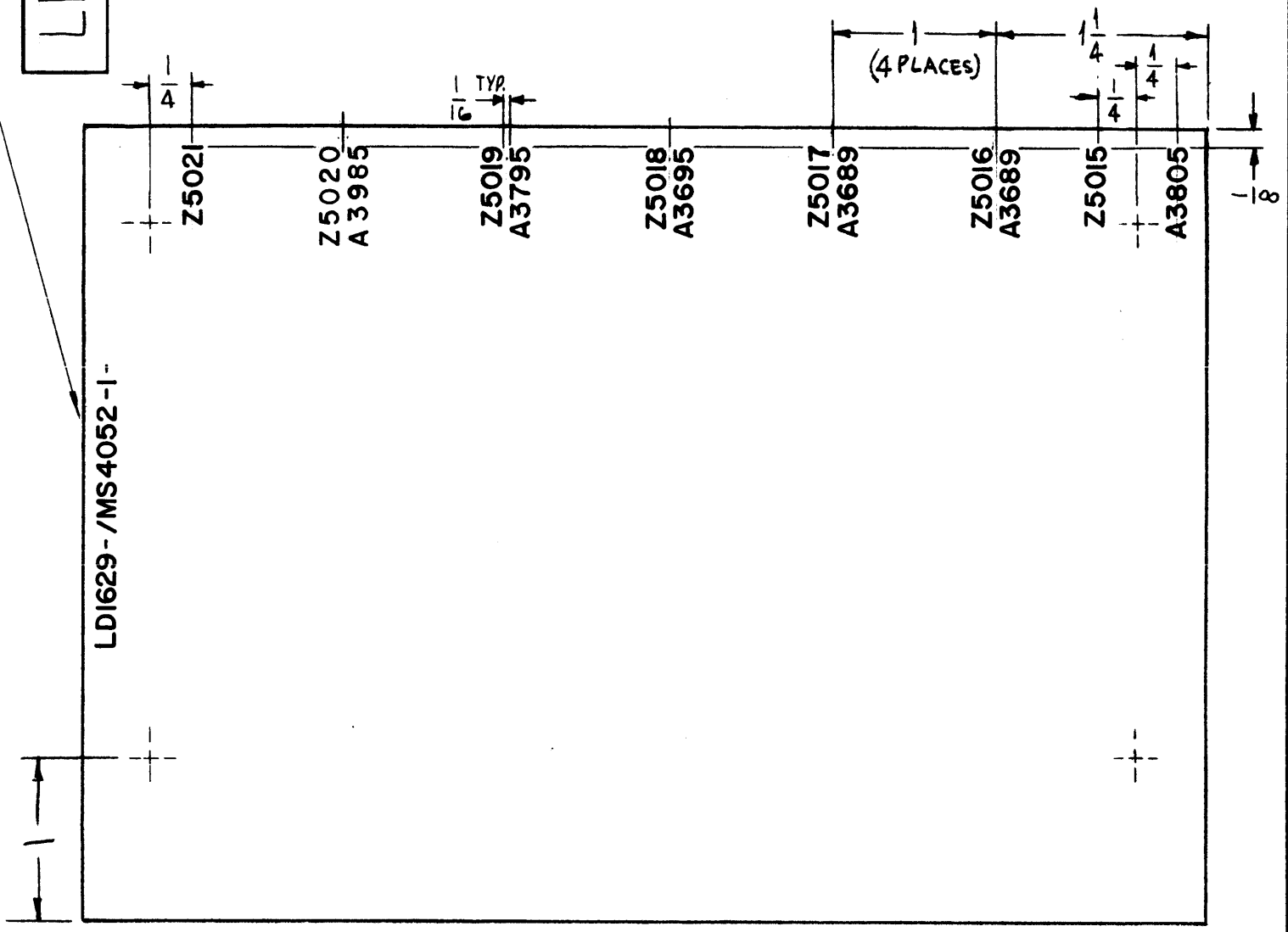
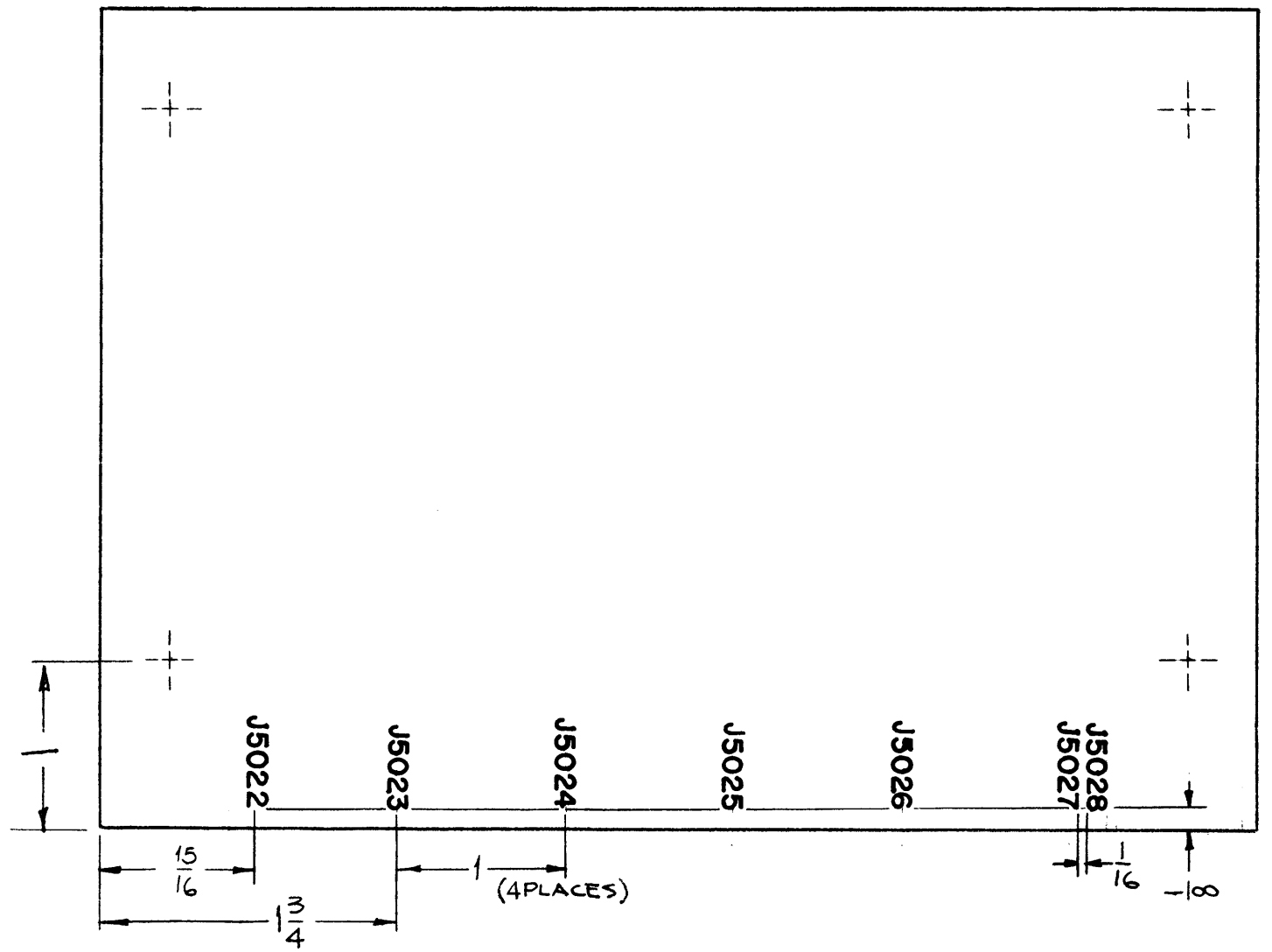

REF: MS 4052-1

MARKING PROCESS: AS PER TMC SPECIFICATION S-727.

LETTERING: 1/8 HIGH BLACK GOTHIC, LOCATED AS SHOWN

NOTES

1	RTMU-1	A3908
QTY./UNIT	MODEL USED ON	ASSY. NO.
SCALE 1:1	CODE A	

THE CONTENTS OF THIS DRAWING ARE THE EXCLUSIVE PROPERTY OF THE TECHNICAL MATERIEL CORP. ITS UNAUTHORIZED USE OR REPRODUCTION IN WHOLE OR IN PART IS STRICTLY FORBIDDEN.

REQ'D.	ITEM	PART NUMBER	DESCRIPTION	SYMBOL
F.E. EATON LIST OF MATERIAL				
MATERIAL		THE TECHNICAL MATERIEL CORP. MAMARONECK, NEW YORK		
FINISH		TITLE MARKING, PLATE SIDE, PC. CARD BIN MARKING PROCESS: AS PER TMC SPEC. S-727		
UNLESS OTHERWISE SPECIFIED DIMENSIONS ARE IN INCHES AND INCLUDE CHEMICALLY APPLIED OR PLATED FINISHES		DRAWN SRG	DATE 10-12-64	FINAL APPROVAL
DECIMALS .X ± .05 .XX ± .01 .XXX ± .05		CHECKED @	DATE 1-18-65	DATE
FRACTIONS ± 1/64 ANGLES ± 0° 30'		ELECT. DES. W.J. JORDAN	DATE 1/18/65	DATE
TOLERANCES		MECH. DES. W.J. JORDAN	DATE 1/18/65	DATE
			SHEET	REV. LTR.

MARKING PROCESS: AS PER TMC SPECIFICATION S-727.  
 LETTERING: 1/8 HIGH BLACK GOTHIC, LOCATED AS SHOWN.

LD1630 B

REVISIONS						
SYM	DESCRIPTION	DATE	E.M.N. NO.	DRAFT	CHKD	APPD
X	EXP. RELEASE	10-12-64	X	G.D.L	JM	W.J.
X1	Z1000, 1001, 1002, 1004, 1005 & 1006 RELOCATED	11-17-64	X1	G.D.L	JM	W.J.
A	ORIGINAL RELEASE FOR PRODUCTION	2-10-65		G.D.L	JM	W.J.
A	Z1000 WAS Z1006; Z1001 WAS Z1005; Z1002 WAS Z1004; Z1004 WAS Z1002; Z1005 WAS Z1001; Z1006 WAS Z1000.	3-11-65	13575	G.D.L	BU	JL
B	A3695 WAS A3693	5-14-65	14079	CJC	JL	JL

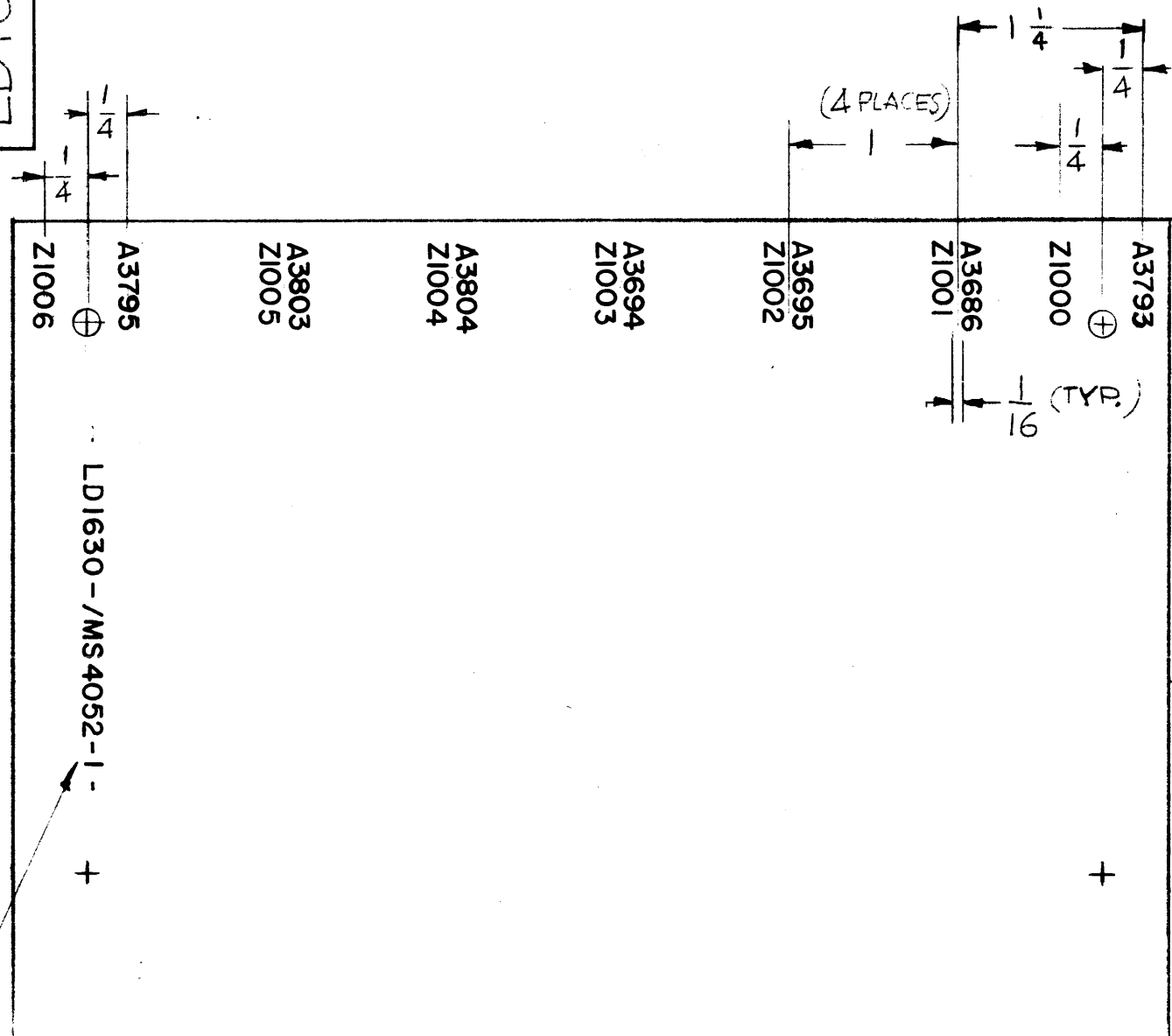
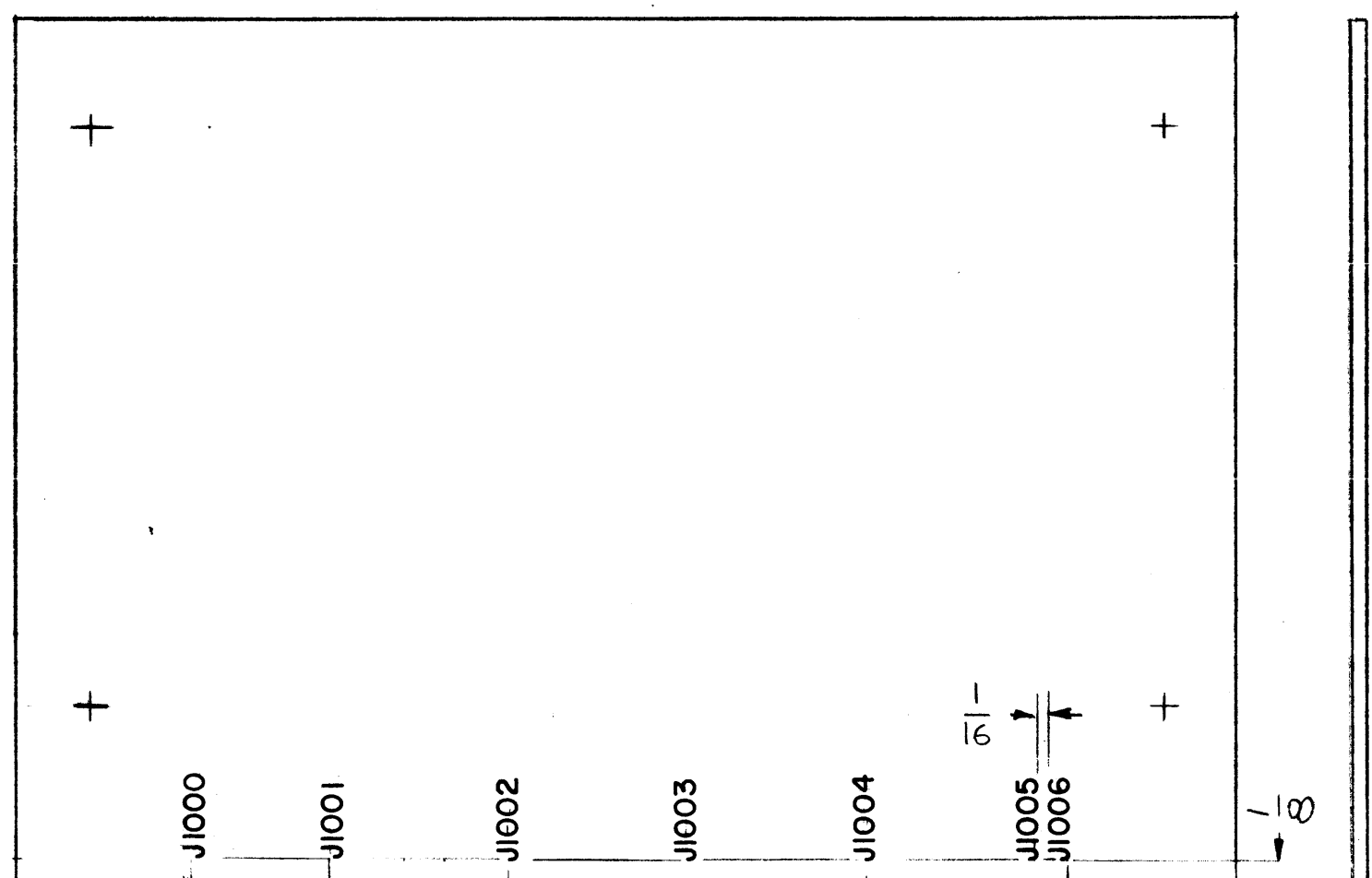

REF: MS 4052-1

MARK TMC PART No. WITH LATEST REVISION LETTER

QTY./UNIT	MODEL USED ON	ASS'Y. NO.
SCALE 1:1	CODE A	A3684
RTPA-1		

REQ'D.	ITEM	PART NUMBER	DESCRIPTION	SYMBOL
EATON LIST OF MATERIAL				
MATERIAL		THE TECHNICAL MATERIEL CORP. MAMARONECK, NEW YORK		
FINISH		TITLE MARKING, PLATE SIDE .PC CARD BIN MARKING PROCESS: AS PER TMC SPEC. S727		
UNLESS OTHERWISE SPECIFIED DIMENSIONS ARE IN INCHES AND INCLUDE CHEMICALLY APPLIED OR PLATED FINISHES				
DECIMALS	TOLERANCES	FRACTIONS	DRAWN G.D.L DATE 10-12-64	
.X ± .05		± 1/64	CHECKED G.D.L DATE 2/9/65	
.XX ± .01		ANGLES ± 0° 30'	ELECT. DES. W.J. JORDAN DATE 2/8/65	
.XXX ± .005			MECH. DES. W.J. JORDAN DATE 2/8/65	
THE CONTENTS OF THIS DRAWING ARE THE EXCLUSIVE PROPERTY OF THE TECHNICAL MATERIEL CORP. ITS UNAUTHORIZED USE OR REPRODUCTION IN WHOLE OR IN PART IS STRICTLY FORBIDDEN.			FINAL APPROVAL [Signature] DATE [Blank]	
NOTES			SHEET LD1630 REV. LTR. B	



STAMP TMC PART NO, WITH LATEST REVISION LETTER.

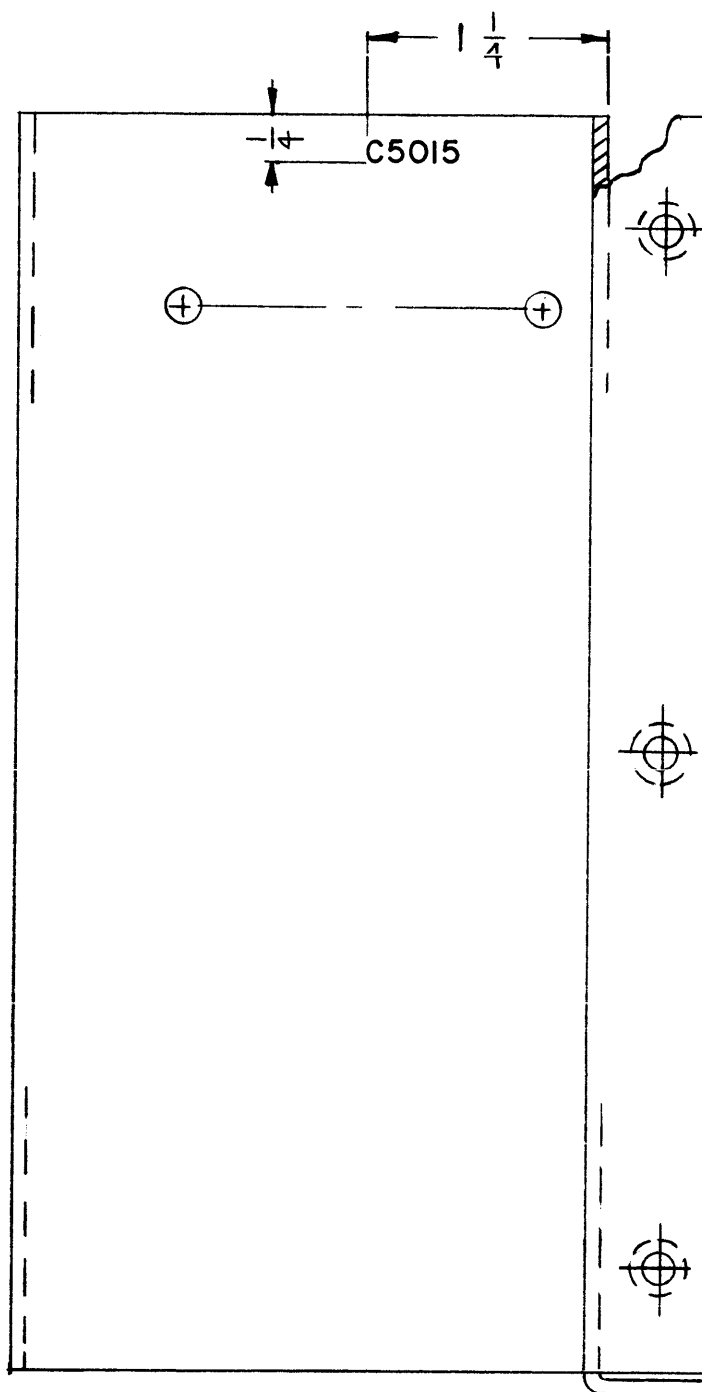
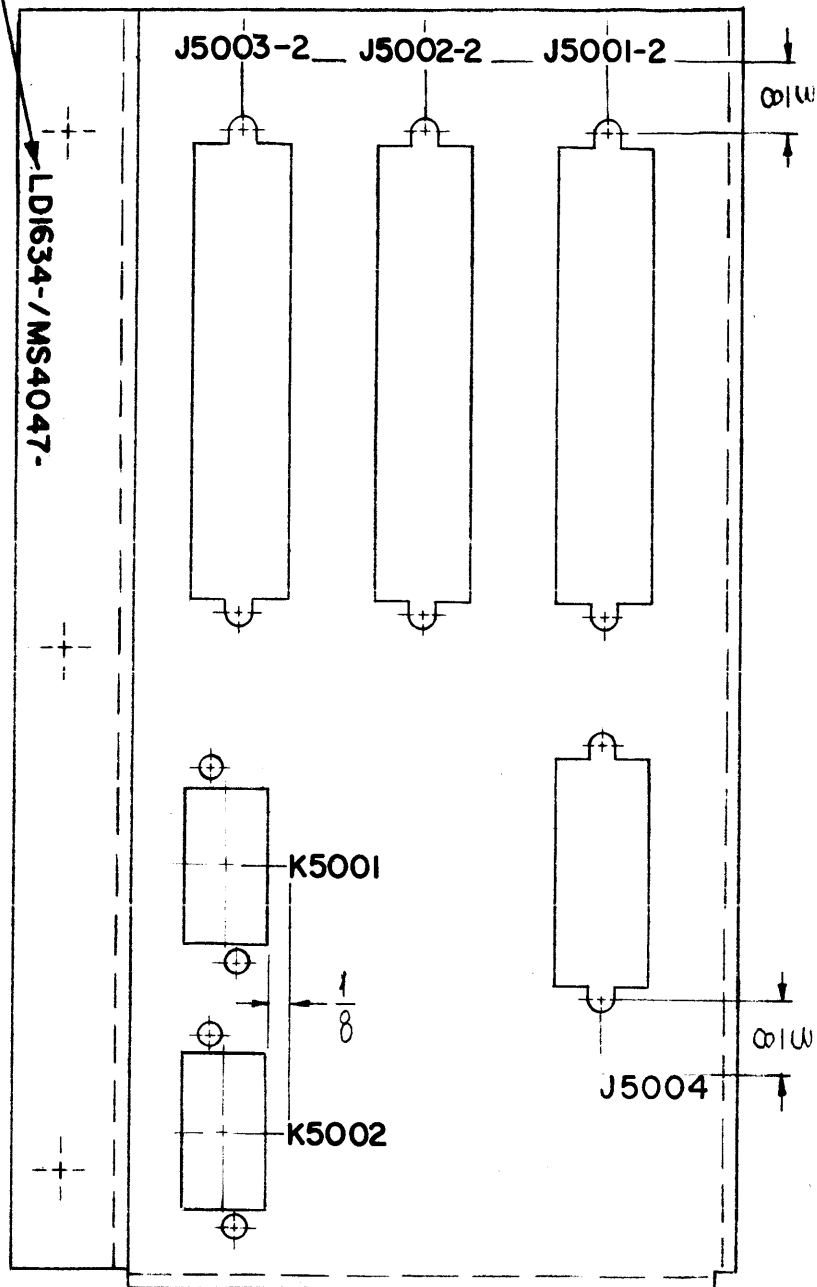

A  
LD1634

REVISIONS

SYM	DESCRIPTION	DATE	E.M.N. NO.	DRAFT	CHKD	APPD
A	REVISED & REDRAWN FROM #1 SIZE; C5015 ADDED.	3-30-65	13635	JF.	JL	[Signature]

REF: MS4047

MARKING PROCESS: AS PER TMC SPECIFICATION S-727.

LETTERING: 1/8 HIGH BLACK GOTHIC, LOCATED AS SHOWN.

1	RTMU-1	A 4052
Q'TY./UNIT	MODEL USED ON	ASS'Y. NO.
SCALE 1:1	CODE A	

THE CONTENTS OF THIS DRAWING ARE THE EXCLUSIVE PROPERTY OF THE TECHNICAL MATERIEL CORP. ITS UNAUTHORIZED USE OR REPRODUCTION IN WHOLE OR IN PART IS STRICTLY FORBIDDEN.

REQ'D.	ITEM	PART NUMBER	DESCRIPTION	SYMBOL
EATON LIST OF MATERIAL				
MATERIAL		THE TECHNICAL MATERIEL CORP. MAMARONECK, NEW YORK		
FINISH		TITLE MARKING, BRACKET MTG. CONNECTOR MARKING PROCESS: AS PER TMC SPEC. S-727		
UNLESS OTHERWISE SPECIFIED DIMENSIONS ARE IN INCHES AND INCLUDE CHEMICALLY APPLIED OR PLATED FINISHES		DRAWN <i>J. Fucina</i>	DATE 3/29/65	FINAL APPROVAL <i>[Signature]</i>
DECIMALS .X ± .05 .XX ± .01 .XXX ± .005		CHECKED	DATE	DATE 8/1/65
FRACTIONS ± 1/64 ANGLES ± 0° 30'		ELECT. DES. <i>[Signature]</i>		DATE 9/1/65
TOLERANCES		MECH. DES.		DATE
LD1634				A
SHEET				REV. LTR.

NOTES

# BOTTOM VIEW

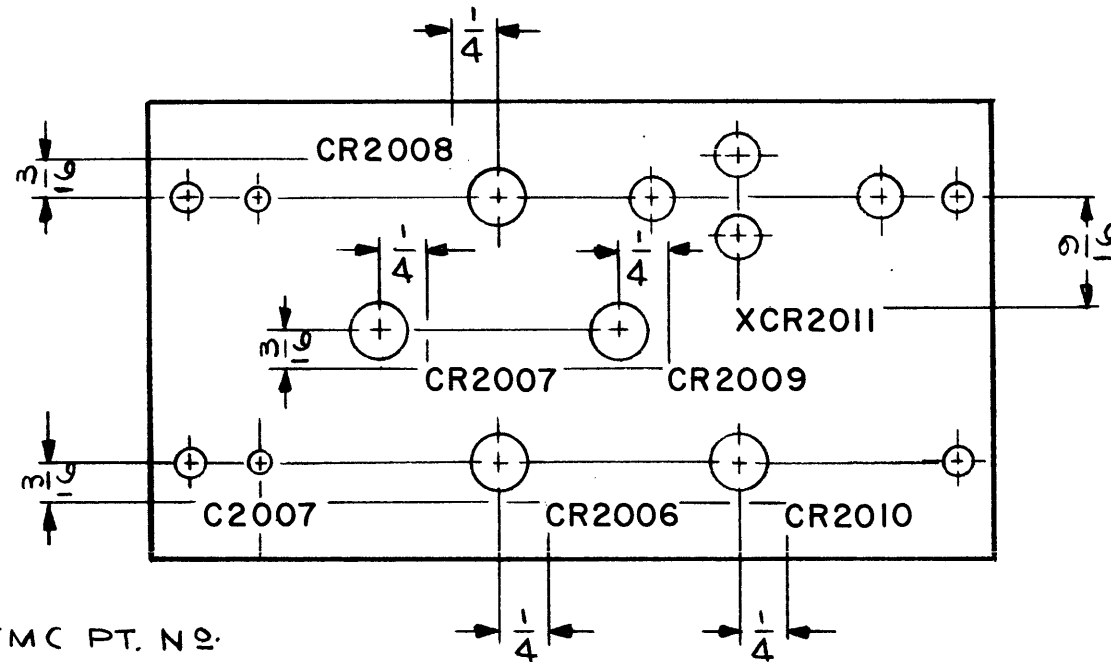

MARK TMC PT. NO.  
W/LATEST REV. LETTERS

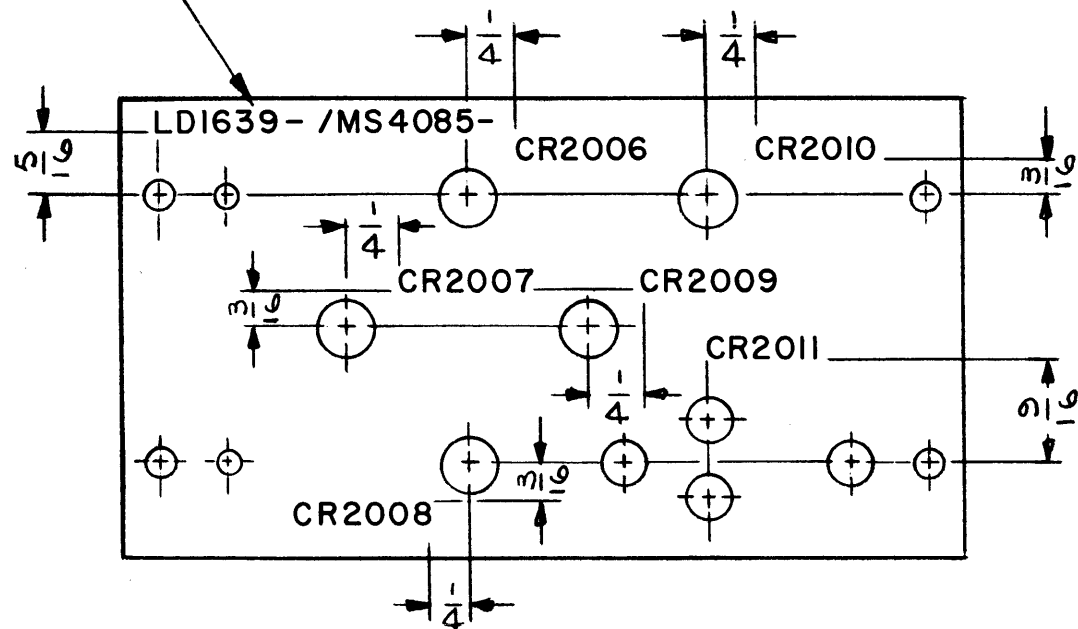

# TOP VIEW

LD1639

REVISIONS					
SYM	DESCRIPTION	DATE	E.M.N. NO.	DRAFT	CHKD APPD
X	EXP. RELEASE	11/11/64		JL	JM
<del>Ø</del>	ORIGINAL RELEASE FOR PRODUCTION	2/10/65		JL	JCB

~ UNLESS OTHERWISE SPECIFIED ~

- 1- MARKING PROCESS: AS PER TMC SPECIFICATION S-727.
- 2- LETTERING: 1/8 HIGH BLACK GOTHIC, LOCATED AS SHOWN.

REF: MS4085

REQ'D.	ITEM	PART NUMBER	DESCRIPTION	SYMBOL
F. E. EATON LIST OF MATERIAL				
MATERIAL		THE TECHNICAL MATERIEL CORP. MAMARONECK, NEW YORK		
FINISH		TITLE MARKING - COMPONENT MTG PLATE (- 12V POWER SUPPLY)		
UNLESS OTHERWISE SPECIFIED DIMENSIONS ARE IN INCHES AND INCLUDE CHEMICALLY APPLIED OR PLATED FINISHES		DRAWN J. LESHINSKI DATE 11/11/64	FINAL APPROVAL DATE JCB LD1639	
DECIMALS .X ± .05 .XX ± .01 .XXX ± .005		TOLERANCES FRACTIONS ± 1/64 ANGLES ± 0° 30'	CHECKED JM DATE 2/8/65	DATE 2/8/65
THE CONTENTS OF THIS DRAWING ARE THE EXCLUSIVE PROPERTY OF THE TECHNICAL MATERIEL CORP. ITS UNAUTHORIZED USE OR REPRODUCTION IN WHOLE OR IN PART IS STRICTLY FORBIDDEN.		MECH. DES. W. JORDAN DATE 2/8/65	SHEET	REV. LTR.

1	RTIA-1	A4067
Q'TY./UNIT	MODEL USED ON	ASS'Y. NO.
SCALE 1:1	CODE A	

## NOTES

BOTTOM VIEW

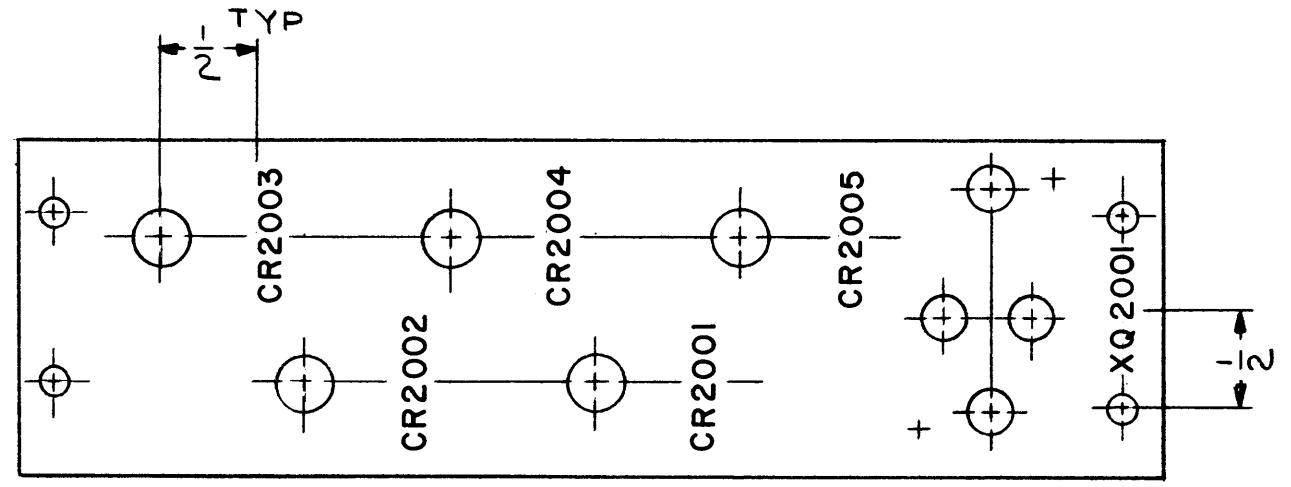

LD1640 Ø

REVISIONS					
SYM	DESCRIPTION	DATE	E.M.N. NO.	DRAFT	CHKD APPD
X	EXP. RELEASE	11/10/64		JL	JM
Ø	ORIGINAL RELEASE FOR PRODUCTION	2-10-65		JL	JM

~ UNLESS OTHERWISE SPECIFIED ~

- 1- MARKING PROCESS: AS PER TMC SPECIFICATION S-727.
- 2- LETTERING: 1/8 HIGH BLACK GOTHIC, LOCATED AS SHOWN.

MARK TMC PT NO W/LATEST REV. LETTERS

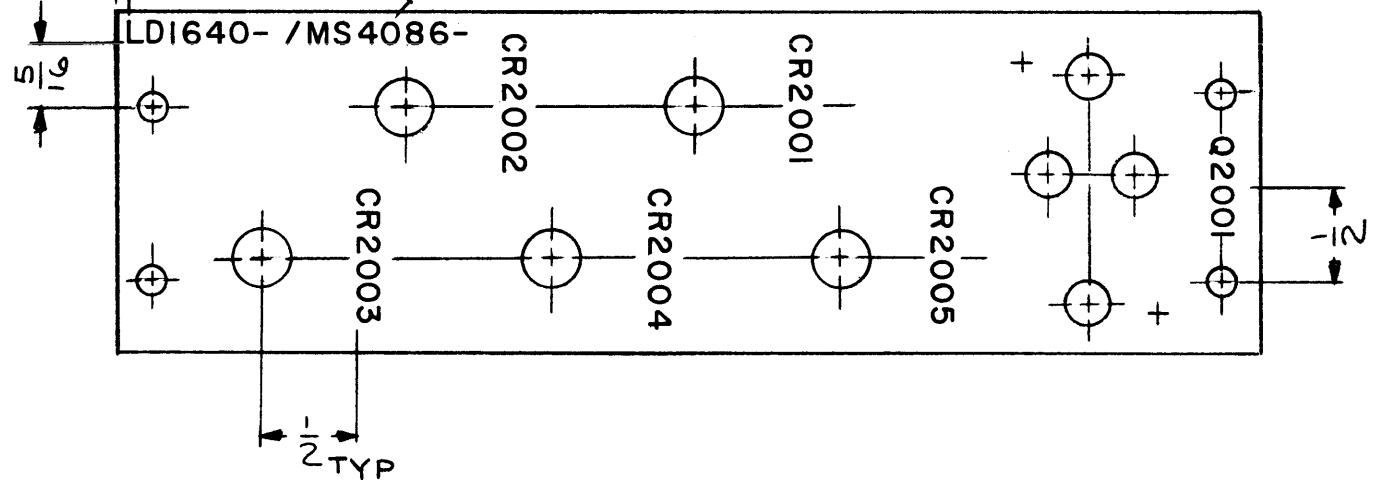

TOP VIEW

REF: MS4086

REQ'D.	ITEM	PART NUMBER	DESCRIPTION	SYMBOL
<b>F. E. EATON LIST OF MATERIAL</b>				
MATERIAL		THE TECHNICAL MATERIEL CORP. MAMARONECK, NEW YORK		
FINISH		TITLE MARKING - COMPONENT MTG PLATE (+12 V POWER SUPPLY)		
UNLESS OTHERWISE SPECIFIED DIMENSIONS ARE IN INCHES AND INCLUDE CHEMICALLY APPLIED OR PLATED FINISHES		DRAWN J. LESHINSKI DATE 11/10/64	FINAL APPROVAL DATE LD1640	
DECIMALS .X ± .05 .XX ± .01 .XXX ± .005		TOLERANCES FRACTIONS ± 1/64 ANGLES ± 0° 30'	CHECKED J.M. DATE 2/18/65	DATE 2/18/65
THE CONTENTS OF THIS DRAWING ARE THE EXCLUSIVE PROPERTY OF THE TECHNICAL MATERIEL CORP. ITS UNAUTHORIZED USE OR REPRODUCTION IN WHOLE OR IN PART IS STRICTLY FORBIDDEN.		MECH. DES. W. JORDAN DATE 2/18/65	REV. LTR.	

I	RTIA-1	A4068
Q'TY./UNIT	MODEL USED ON	ASS'Y. NO.
SCALE 1:1	CODE A	

NOTES

TOP VIEW

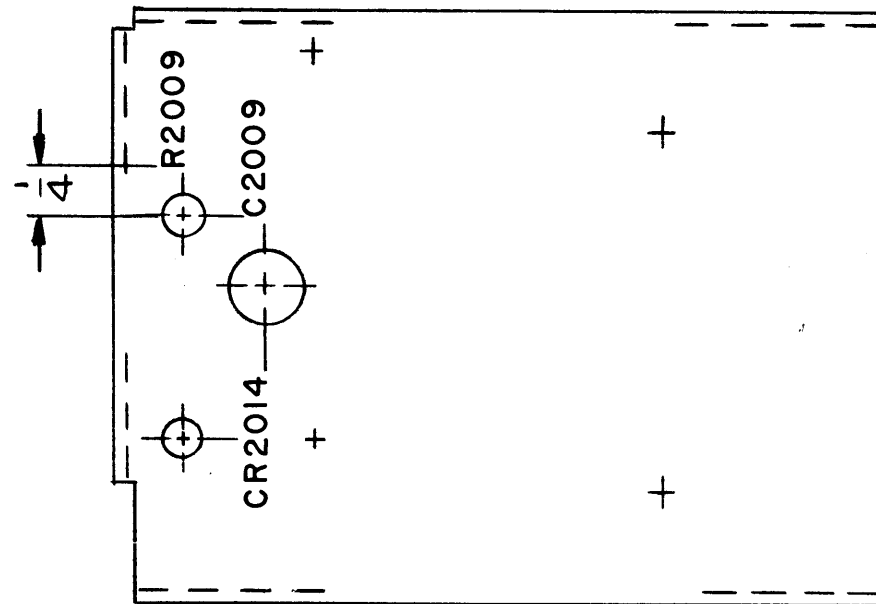

BOTTOM VIEW

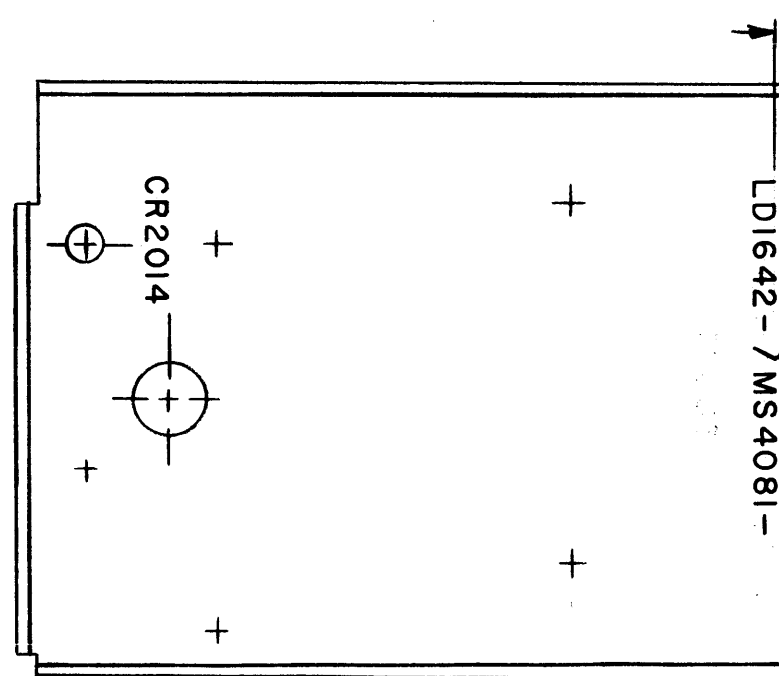

MARK TMC PT. NO.  
W/LATEST REV. LETTER

LD1642

REVISIONS

SYM	DESCRIPTION	DATE	E.M.N. NO.	DRAFT	CHKD	APPD
X	EXP. RELEASE	1/12/64		JL		
X <sub>1</sub>	REMOVED T2002 & CUTOUT REF. PICTORIAL; ADDED 1/2 DIM.	1/8/64		JL	JM	W.J.
Ø	ORIGINAL RELEASE FOR PRODUCTION.	2-10-65	Ø	J.L.	JCB	

~ UNLESS OTHERWISE SPECIFIED ~

- 1- MARKING PROCESS: AS PER TMC SPECIFICATION S-727.
- 2- LETTERING: 1/8 HIGH BLACK GOTHIC, LOCATED AS SHOWN.

REF: MS4081

REQ'D.	ITEM	PART NUMBER	DESCRIPTION	SYMBOL
<b>F. E. EATON LIST OF MATERIAL</b>				
MATERIAL		<b>THE TECHNICAL MATERIEL CORP.</b> MAMARONECK, NEW YORK		
FINISH		TITLE MARKING - CHASSIS, MAIN (+180 V POWER SUPPLY)		
UNLESS OTHERWISE SPECIFIED DIMENSIONS ARE IN INCHES AND INCLUDE CHEMICALLY APPLIED OR PLATED FINISHES		DRAWN JL	DATE 11-12-64	FINAL APPROVAL JCB
DECIMALS .X ± .05 .XX ± .01 .XXX ± .005		CHECKED J.M. Jordan	DATE 2/9/65	DATE 2/8/65
FRACTIONS ± 1/64 ANGLES ± 0° 30'		ELECT. DES. W. Jordan	DATE 2/8/65	DATE 2/8/65
TOLERANCES		MECH. DES.	DATE	DATE
		W. JORDAN	2/8/65	2/8/65
SHEET				REV. LTR.

1	RTIA-1	A4058
QTY./UNIT	MODEL USED ON	ASS'Y. NO.
SCALE 1:1	CODE A	
THE CONTENTS OF THIS DRAWING ARE THE EXCLUSIVE PROPERTY OF THE TECHNICAL MATERIEL CORP. ITS UNAUTHORIZED USE OR REPRODUCTION IN WHOLE OR IN PART IS STRICTLY FORBIDDEN.		

NOTES

LD1649

REVISIONS					
SYM	DESCRIPTION	DATE	E.M.N. NO.	DRAFT	CHKD APPD
X	EXP. RELEASE	11-4-64	X	SRG	
Ø	ORIGINAL RELEASE FOR PRODUCTION	8/7/69	Ø	Ø	

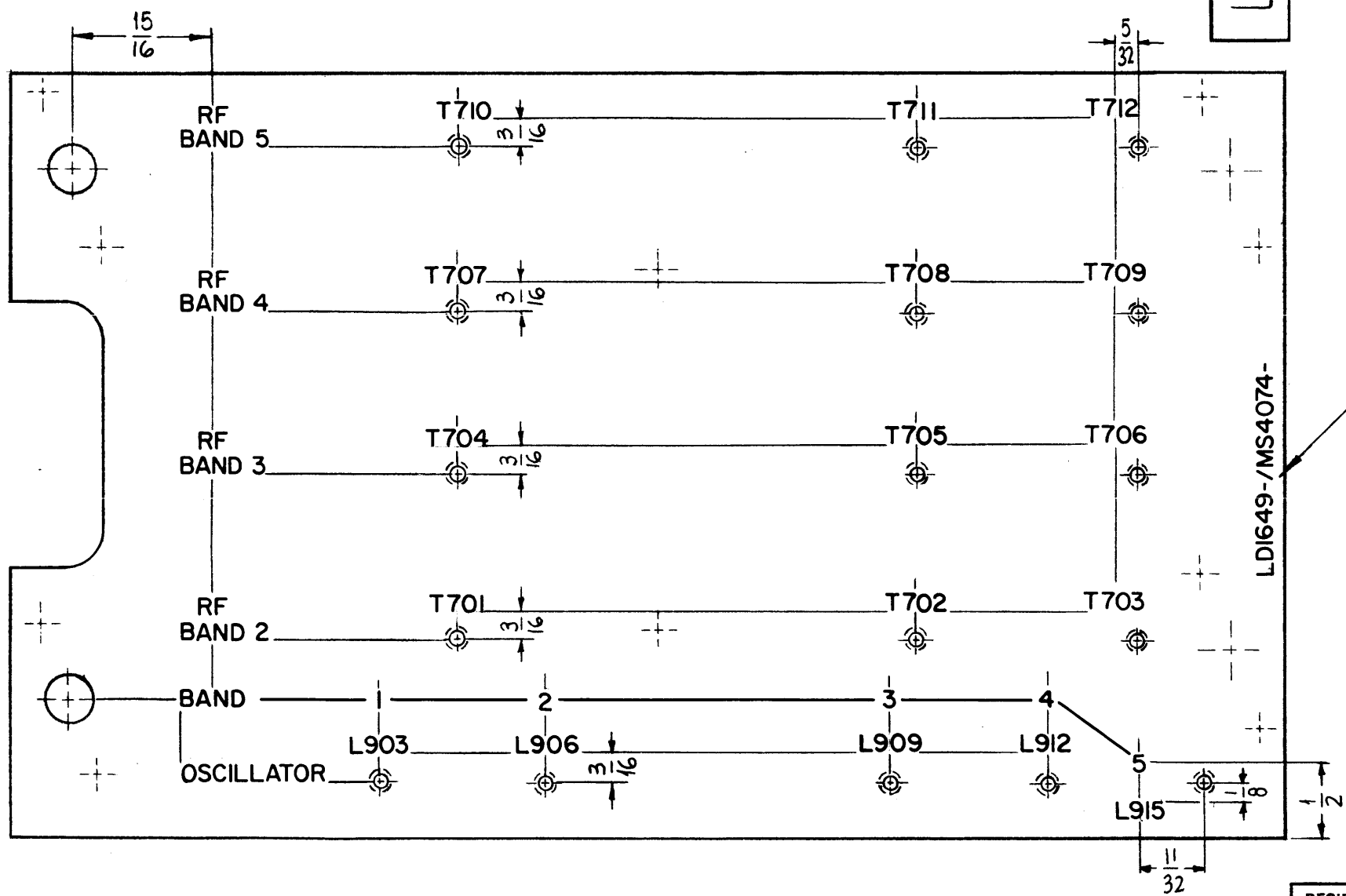

LD1649-MS4074-

MARK TMC PART NO. W/LATEST REV. LETTER.

REF: MS4074

**MARKING PROCESS: AS PER TMC SPECIFICATION S-727.**  
**LETTERING: 1/8 HIGH BLACK GOTHIC, LOCATED AS SHOWN.**  
 LINES: BLACK, AS SHOWN

1	VLRB-1	
Q'TY./UNIT	MODEL USED ON	ASS'Y. NO.
SCALE 1:1	CODE A	

THE CONTENTS OF THIS DRAWING ARE THE EXCLUSIVE PROPERTY OF THE TECHNICAL MATERIEL CORP. ITS UNAUTHORIZED USE OR REPRODUCTION IN WHOLE OR IN PART IS STRICTLY FORBIDDEN.

REQ'D.	ITEM	PART NUMBER	DESCRIPTION	SYMBOL
M.GELLMAN LIST OF MATERIAL				
MATERIAL			THE TECHNICAL MATERIEL CORP. MAMARONECK, NEW YORK	
FINISH			TITLE MARKING, PLATE, SLUG MARKING PROCESS: AS PER TMC SPEC S727	
UNLESS OTHERWISE SPECIFIED DIMENSIONS ARE IN INCHES AND INCLUDE CHEMICALLY APPLIED OR PLATED FINISHES		DRAWN SRG	DATE 11-4-64	FINAL APPROVAL [Signature] DATE 8/7/69
DECIMALS .X ± .05 .XX ± .01 .XXX ± .005		TOLERANCES		FRACTIONS ± 1/64 ANGLES ± 0° 30'
ELECT. DES.		DATE		LD1649
MECH. DES.		DATE		Ø
SHEET				REV. LTR.

NOTES

LD1662-D

REVISIONS

SYM	DESCRIPTION	DATE	E.M.N. NO.	DRAFT	CHKD	APPD
X	EXP. RELEASE	1/9/64	X	JL		
Q	ORIGINAL RELEASE FOR PRODUCTION	1-18-65	Q	JM	J.M.	
A	HOLE ADD. TO CONFORM TO MS 4046	2-15-65	13446	JF	J.P.	J.P.
B	R5013 & C5014 ADDED; R5031 WAS R5027; R5032 WAS R5028, Z5015 TO 2, J5022 TO 2, A3689 (2 PLACES) A3695, A3795, A3805	3-29-65	13620	9L	J.P.	J.P.
C	A3985, C5010, C5011, C5009, ADDED. RELOCATE PT. NO. LETTERS	7/30/65	14533	H.V.	J.P.	J.P.
D	DIM 1, 3/8, 1 RELOCATED, 1/2" WAS 3/16"	8/26/65	14716	H.V.	J.P.	J.P.

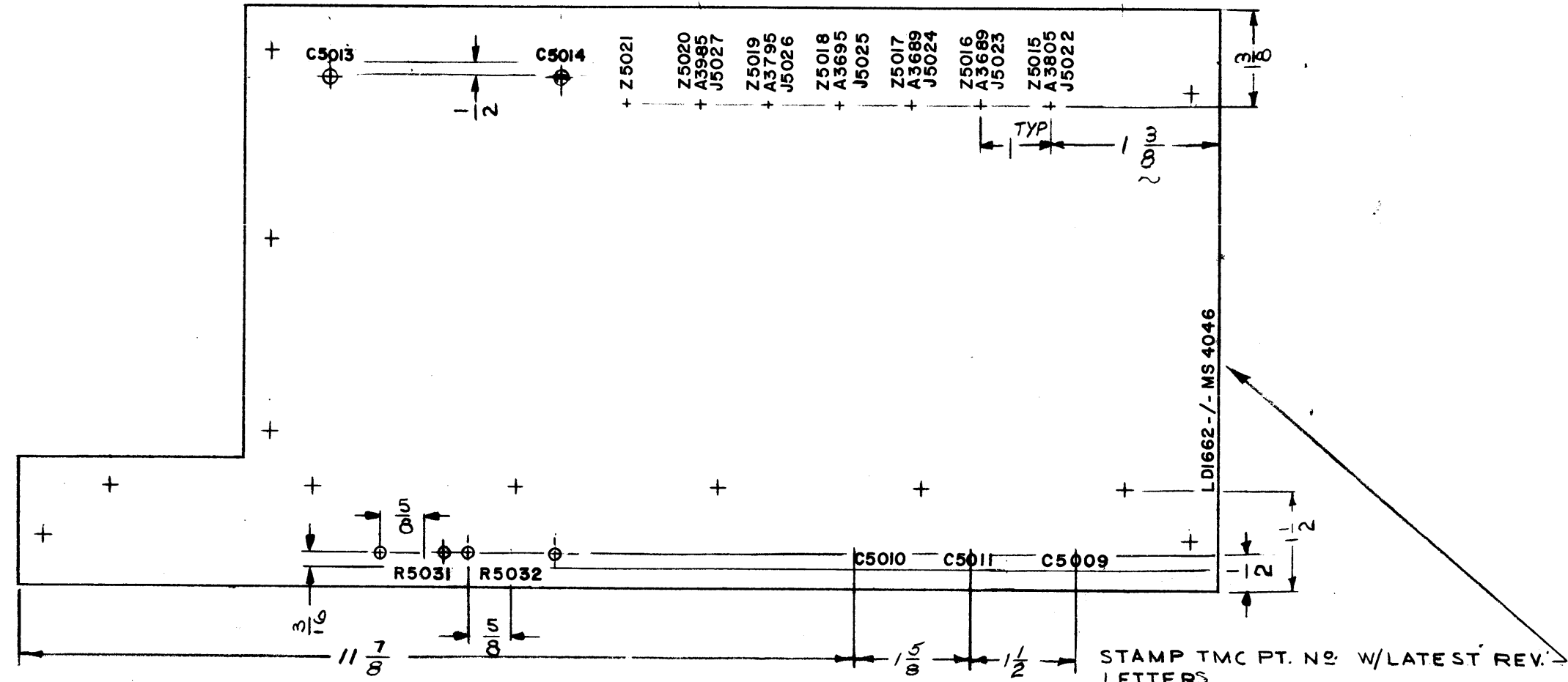

~ UNLESS OTHERWISE SPECIFIED ~

- 1- MARKING PROCESS: AS PER TMC SPECIFICATION S-727.
- 2- LETTERING: 1/8 HIGH BLACK GOTHIC, LOCATED AS SHOWN.

REF. MS 4046

REQ'D.	ITEM	PART NUMBER	DESCRIPTION	SYMBOL
F. E. EATON LIST OF MATERIAL				
MATERIAL			THE TECHNICAL MATERIEL CORP. MAMARONECK, NEW YORK	
FINISH			TITLE MARKING- PLATE, REAR MARKING PROCESS PER TMC 5727	
UNLESS OTHERWISE SPECIFIED DIMENSIONS ARE IN INCHES AND INCLUDE CHEMICALLY APPLIED OR PLATED FINISHES			DRAWN J. LESHINSKI DATE 11/9/64 CHECKED J. MUMFORD DATE 1-18-65 ELECT. DES. W. JORDAN DATE 1/18/65 MECH. DES. W. JORDAN DATE 1/18/65	
DECIMALS .X ± .05 .XX ± .01 .XXX ± .005			FRACTIONS ± 1/64 ANGLES ± 0° 30'	
TOLERANCES			FINAL APPROVAL DATE SHEET REV. LTR.	

1	RTMU-1	A3909
QTY./UNIT	MODEL USED ON	ASSY. NO.
SCALE 1:2	CODE A	
THE CONTENTS OF THIS DRAWING ARE THE EXCLUSIVE PROPERTY OF THE TECHNICAL MATERIEL CORP. ITS UNAUTHORIZED USE OR REPRODUCTION IN WHOLE OR IN PART IS STRICTLY FORBIDDEN.		

NOTES

LD1664

REVISIONS					
SYM	DESCRIPTION	DATE	E.M.N. NO.	DRAFT	CHKD APPD
X	EXPER. RELEASE	12-18-64		G.D.L	
Ø	ORIGINAL RELEASE FOR PRODUCTION	12-28-64		Ø	

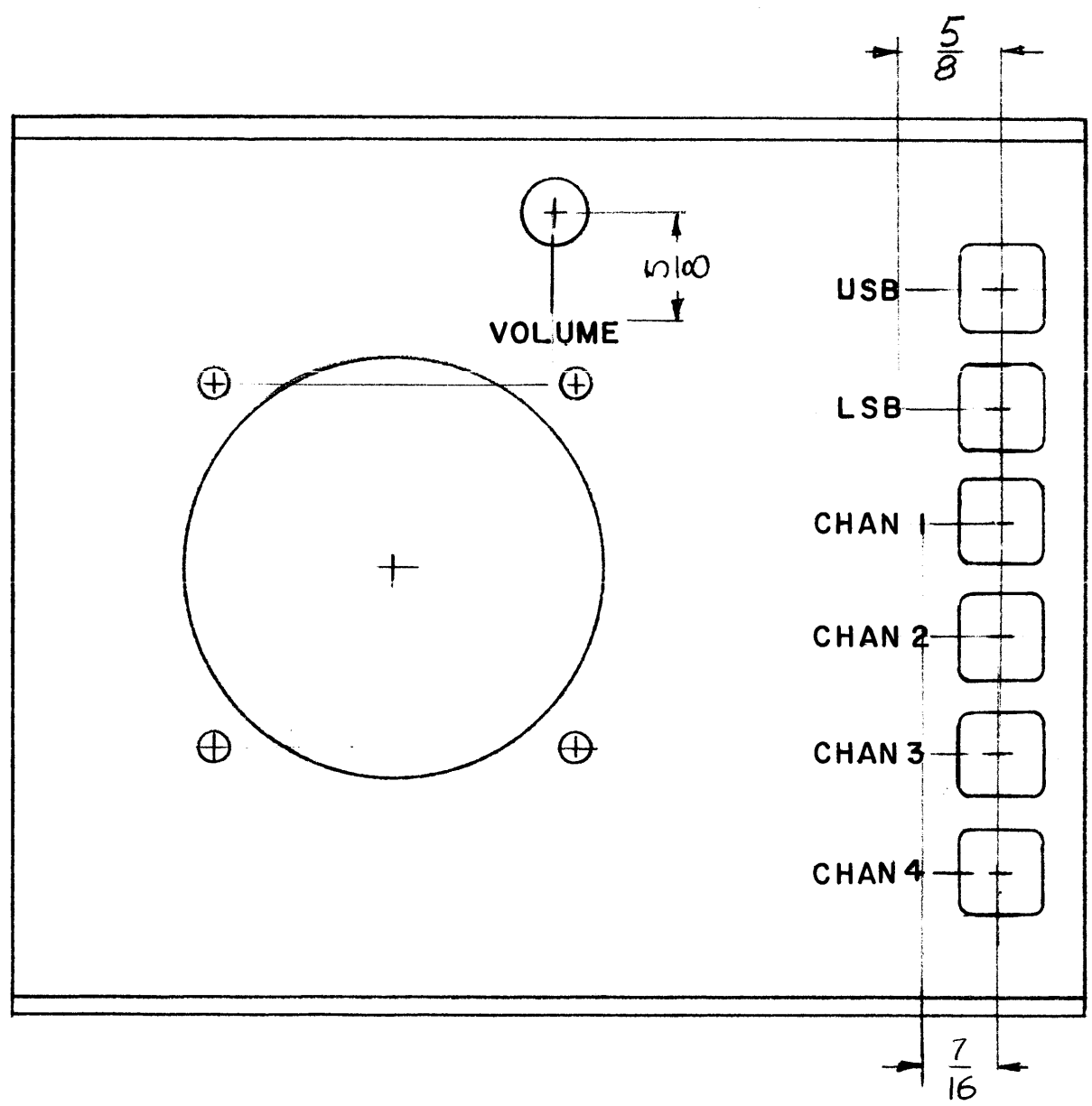

UNLESS OTHERWISE SPECIFIED

- 1- ALL LETTERING TO BE BLACK FILLED.
- 2- ALL LETTERING TO BE 1/8 HIGH X .010 DEPTH OF STROKE X .020 WIDTH OF STROKE
- 3- ALL LETTERING TO BE CENTERED ON HOLES

REF: PX 878

1	SMC-1 & TPC-1	
Q'TY./UNIT	MODEL USED ON	ASS'Y. NO.
SCALE 1:1	CODE	

REQ'D.	ITEM	PART NUMBER	DESCRIPTION	SYMBOL
	O. POSE		LIST OF MATERIAL	
MATERIAL		THE TECHNICAL MATERIEL CORP. MAMARONECK, NEW YORK		
FINISH		TITLE MARKING METHOD: ENGRAVING MARKING PROCESS: PER TMC SPEC 5727		
UNLESS OTHERWISE SPECIFIED DIMENSIONS ARE IN INCHES AND INCLUDE CHEMICALLY APPLIED OR PLATED FINISHES		DRAWN G.D.L	DATE 12-18-64	FINAL APPROVAL RML
DECIMALS .X ± .05 .XX ± .01 .XXX ± .005		CHECKED @	DATE 12-21-64	DATE 12-23-64
FRACTIONS ± 1/64 ANGLES ± 0° 30'		ELECT. DES. M.D.	DATE 12-23-64	LD1664
TOLERANCES		MECH. DES. [Signature]	DATE	Ø
			SHEET	REV. LTR.

NOTES

THE CONTENTS OF THIS DRAWING ARE THE EXCLUSIVE PROPERTY OF THE TECHNICAL MATERIEL CORP. ITS UNAUTHORIZED USE OR REPRODUCTION IN WHOLE OR IN PART IS STRICTLY FORBIDDEN.

LD1665

REVISIONS					
SYM	DESCRIPTION	DATE	E.M.N. NO.	DRAFT	CHKD APPD
X	EXPERIMENTAL RELEASE	12-14-64		G.D.L.	
Ø	ORIGINAL RELEASE FOR PRODUCTION	1-28-65	Ø	F.P.	

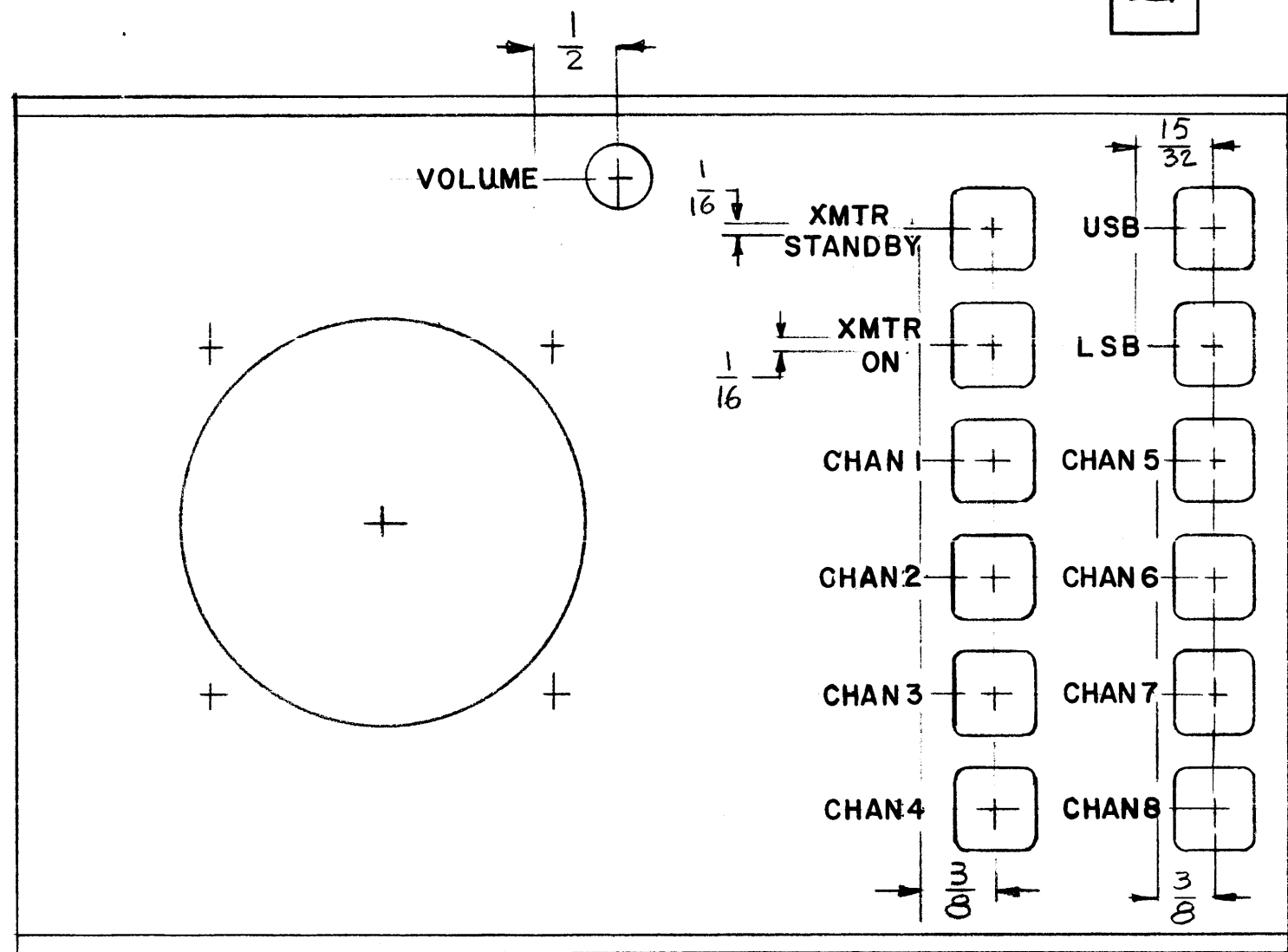

- UNLESS OTHERWISE SPECIFIED -
- 1- ALL LETTERING TO BE BLACK FILLED.
- 2- ALL LETTERING TO BE 1/8 HIGH X .010 DEPTH OF STROKE X .020 WIDTH OF STROKE
- 3- ALL LETTER GROUPS TO BE CENTERED ON HOLES

REF: PX 870

1	TPC-11	
Q'TY./UNIT	MODEL USED ON	ASS'Y. NO.
SCALE 1:1	CODE Δ	

NOTES

THE CONTENTS OF THIS DRAWING ARE THE EXCLUSIVE PROPERTY OF THE TECHNICAL MATERIEL CORP. ITS UNAUTHORIZED USE OR REPRODUCTION IN WHOLE OR IN PART IS STRICTLY FORBIDDEN.

REQ'D.	ITEM	PART NUMBER	DESCRIPTION	SYMBOL
O.POSE LIST OF MATERIAL				
MATERIAL		THE TECHNICAL MATERIEL CORP. MAMARONECK, NEW YORK		
FINISH		TITLE MARKING FRONT PANEL MARKING METHOD: ENGRAVING		
UNLESS OTHERWISE SPECIFIED DIMENSIONS ARE IN INCHES AND INCLUDE CHEMICALLY APPLIED OR PLATED FINISHES		DRAWN G.D.L.	DATE 12-14-64	FINAL APPROVAL [Signature]
		CHECKED [Signature]	DATE 12-23-64	
		ELECT. DES [Signature]	DATE	
		MECH. DES [Signature]	DATE 1-27-65	
DECIMALS .X ± .05 .XX ± .01 .XXX ± .005				TOLERANCES
FRACTIONS ± 1/64 ANGLES ± 0° 30'				
LD1665				Ø
SHEET				REV. LTR.



CHART				
TMC P/N	A	B	C	REQ'D
LD1667-1	AX524	J208	J214	1
LD1667-2	AX525	J209	J215	1
LD1667-3	AX526	J210	J216	1

SYM	DESCRIPTION	DATE	EM N NO	DRAFT	CHKD	APPD
Y	EXPER. RELEASE	12-9-64			G.D.L	
Ø	ORIGINAL RELEASE FOR PRODUCTION	8/7/69	φ		Ø	

LD1667

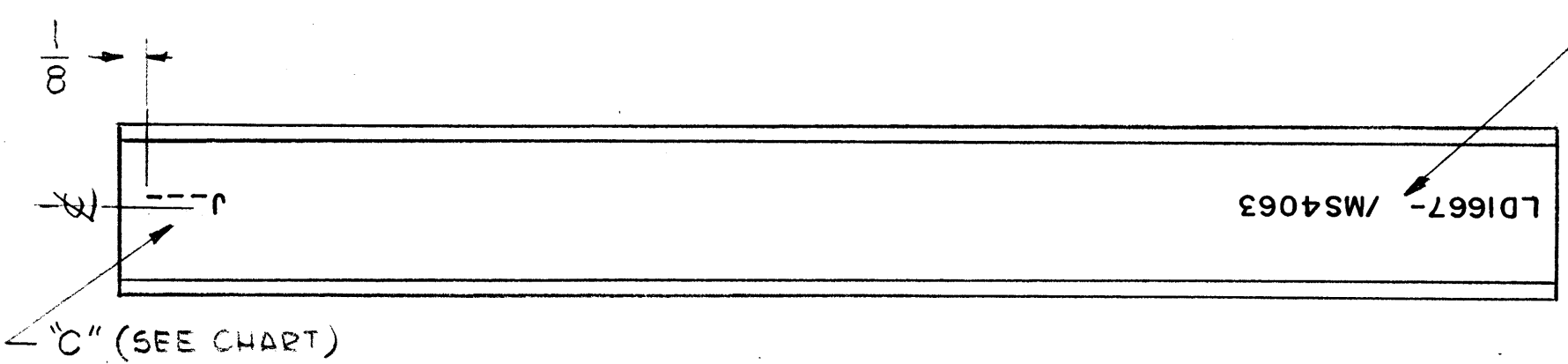
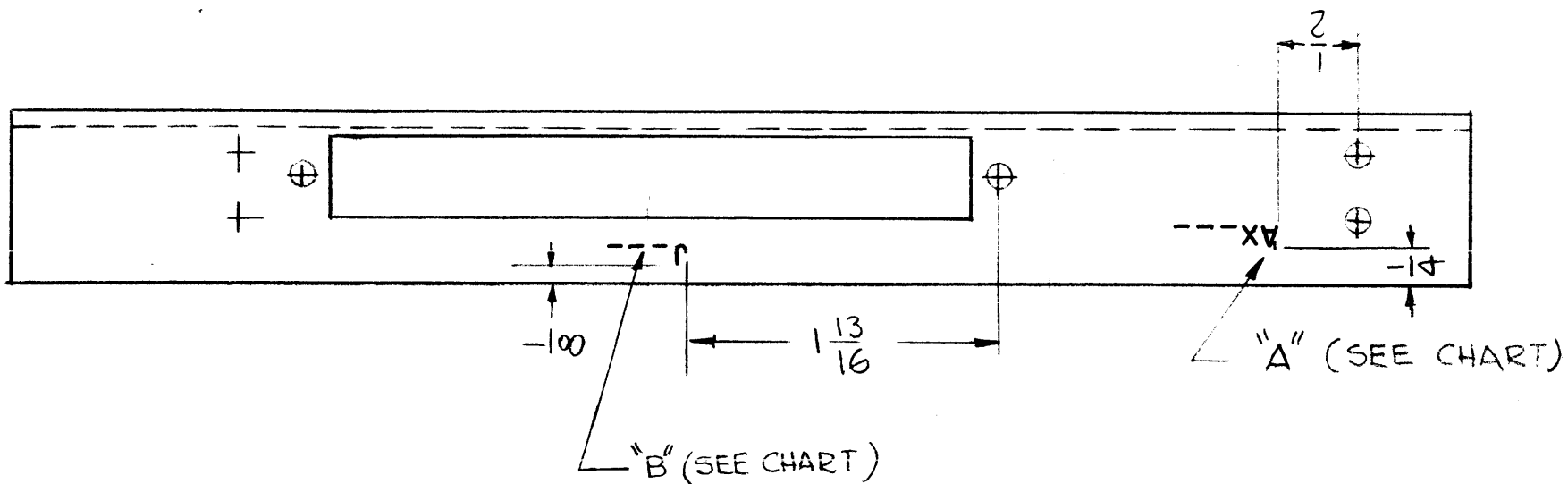

REF: MS 4063

**MARKING PROCESS: AS PER TMC SPECIFICATION S-727.**  
**LETTERING: 1/8 HIGH BLACK GOTHIC, LOCATED AS SHOWN.**

Q'TY./UNIT	VLBB - 1	MODEL USED ON	ASS'Y. NO.
SCALE	1:1	CODE	A

THE CONTENTS OF THIS DRAWING ARE THE EXCLUSIVE PROPERTY OF THE TECHNICAL MATERIEL CORP. ITS UNAUTHORIZED USE OR REPRODUCTION IN WHOLE OR IN PART IS STRICTLY FORBIDDEN.

REQ'D.	ITEM	PART NUMBER	DESCRIPTION	SYMBOL
	0. POSE		LIST OF MATERIAL	
	MATERIAL		THE TECHNICAL MATERIEL CORP. MAMARONECK, NEW YORK	
	FINISH		TITLE MARKING, CHANNEL, MTG RF. CONNECTOR MARKING PROCESS: PER TMC SPEC. S 727	
	UNLESS OTHERWISE SPECIFIED DIMENSIONS ARE IN INCHES AND INCLUDE CHEMICALLY APPLIED OR PLATED FINISHES		DRAWN G.D.L	DATE 12-9-64
	DECIMALS .X ± .05 .XX ± .01 .XXX ± .005		CHECKED	DATE
	FRACTIONS ± 1/64 ± 0° 30'		ELECT. DES.	DATE
	TOLERANCES		MECH. DES.	DATE
			LD1667-	φ
			SHEET	REV. LTR.

NOTES

LD1668

REVISIONS						
SYM	DESCRIPTION	DATE	E.M.N. NO.	DRAFT	CHKD	APPD
X	EXPER. RELEASE	12-8-64		G.D.L.		
Ø	ORIGINAL RELEASE FOR PRODUCTION	8/7/69	Ø	Ø		

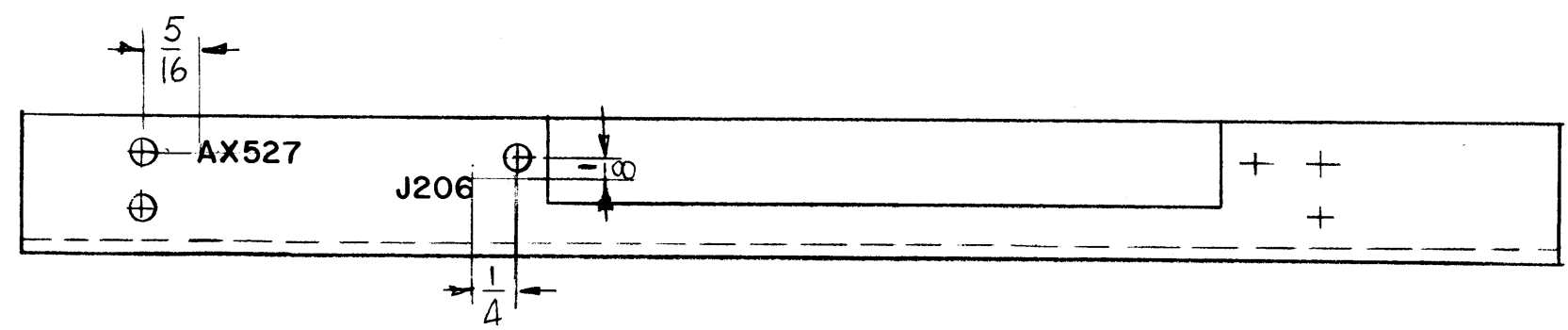
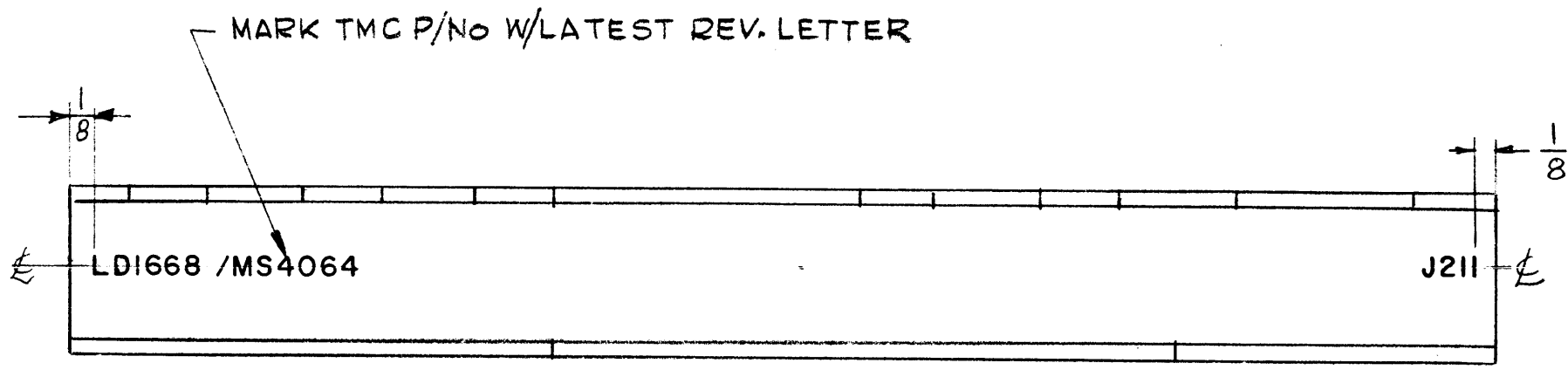

MARKING PROCESS: AS PER TMC SPECIFICATION S-727.  
 LETTERING: 1/8 HIGH BLACK GOTHIC, LOCATED AS SHOWN.

REF: MS4064

1	YLRB-1	
Q'TY./UNIT	MODEL USED ON	ASS'Y. NO.
SCALE	CODE	
1:1	A	

THE CONTENTS OF THIS DRAWING ARE THE EXCLUSIVE PROPERTY OF THE TECHNICAL MATERIEL CORP. ITS UNAUTHORIZED USE OR REPRODUCTION IN WHOLE OR IN PART IS STRICTLY FORBIDDEN.

REQ'D.	ITEM	PART NUMBER	DESCRIPTION	SYMBOL
O. POSE LIST OF MATERIAL				
MATERIAL			THE TECHNICAL MATERIEL CORP. MAMARONECK, NEW YORK	
FINISH			TITLE MARKING CHANNEL, MTG OSC. CONNECTOR MARKING PROCESS: PER TMC SPEC S727	
UNLESS OTHERWISE SPECIFIED DIMENSIONS ARE IN INCHES AND INCLUDE CHEMICALLY APPLIED OR PLATED FINISHES			DRAWN G.D.L.	DATE 12-8-64
			CHECKED	DATE
			ELECT. DES.	DATE
			MECH. DES.	DATE
			SHEET	REV. LTR.

NOTES

LD1669

REVISIONS						
SYM	DESCRIPTION	DATE	E.M.N. NO.	DRAFT	CHKD	APPD
X	EXPER. RELEASE	12-8-64		G.D.L.		
Ø	ORIGINAL RELEASE FOR PRODUCTION	8/7/69		W		

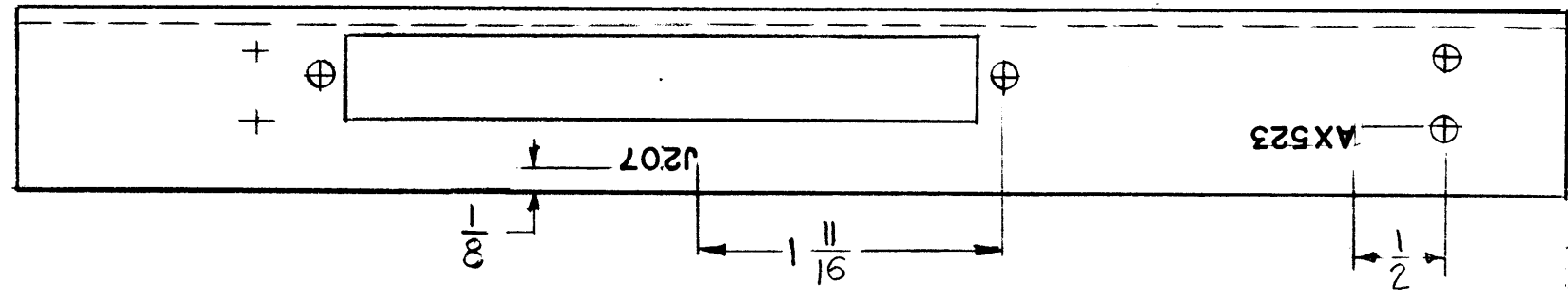

MARKING PROCESS: AS PER TMC SPECIFICATION S-727.  
 LETTERING: 1/8 HIGH BLACK GOTHIC, LOCATED AS SHOWN.

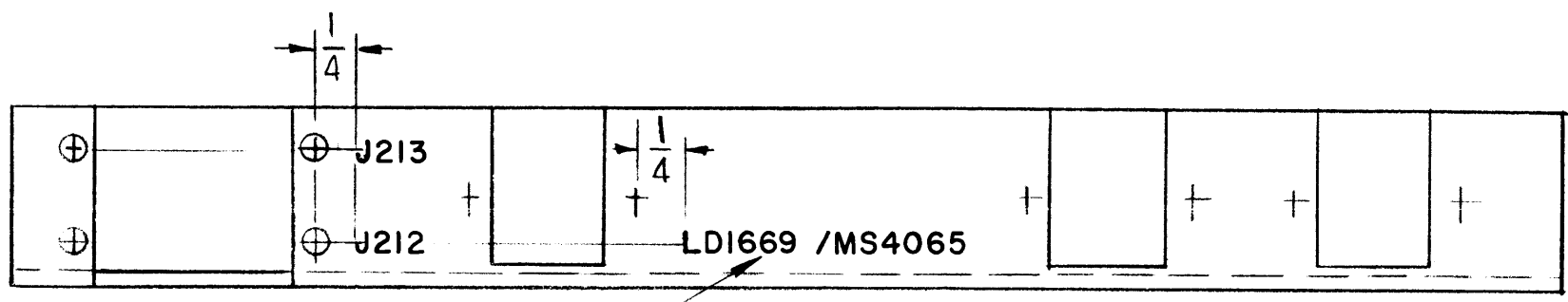
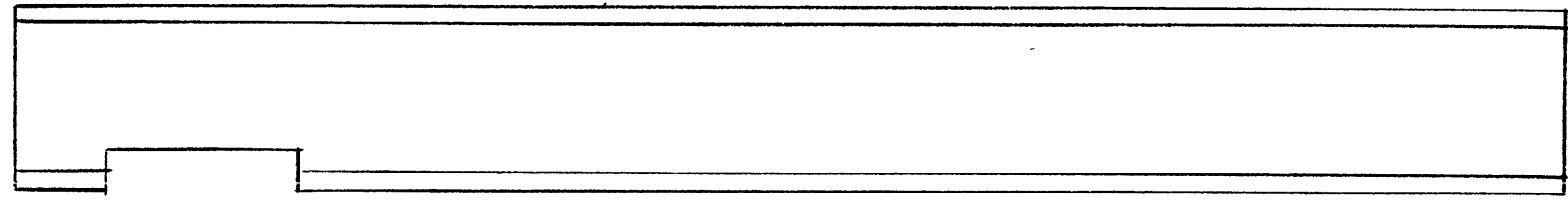

REF: MS 4065

MARK TMC P/No W/LATEST REV. LETTER

Q'TY./UNIT	MODEL USED ON	ASS'Y. NO.
SCALE	CODE	
1:1	A	

THE CONTENTS OF THIS DRAWING ARE THE EXCLUSIVE PROPERTY OF THE TECHNICAL MATERIEL CORP. ITS UNAUTHORIZED USE OR REPRODUCTION IN WHOLE OR IN PART IS STRICTLY FORBIDDEN.

REQ'D.	ITEM	PART NUMBER	DESCRIPTION	SYMBOL
O.POSE LIST OF MATERIAL				
MATERIAL		THE TECHNICAL MATERIEL CORP. MAMARONECK, NEW YORK		
FINISH		TITLE MARKING, CHANNEL MTG, RF CONNECTOR MARKING PROCESS AS PER TMC SPEC S		
UNLESS OTHERWISE SPECIFIED DIMENSIONS ARE IN INCHES AND INCLUDE CHEMICALLY APPLIED OR PLATED FINISHES		DRAWN G.D.L.	DATE 12-8-64	FINAL APPROVAL DATE 8/7/69
DECIMALS .X ± .05 .XX ± .01 .XXX ± .005		TOLERANCES		FRACTIONS ± 1/64 ANGLES ± 0° 30'
ELECT. DES.		DATE		LD1669
MECH. DES.		DATE		Ø
SHEET				REV. LTR.

NOTES

LD1691

REVISIONS						
SYM	DESCRIPTION	DATE	E.M.N. NO.	DRAFT	CHKD	APFD
X1	MS4201 DELETED FROM TMC PT. NO.	12-27-65		Jc		
Ø	ORIGINAL RELEASE FOR PRODUCTION	12/27/65	Ø	Z.V.		file

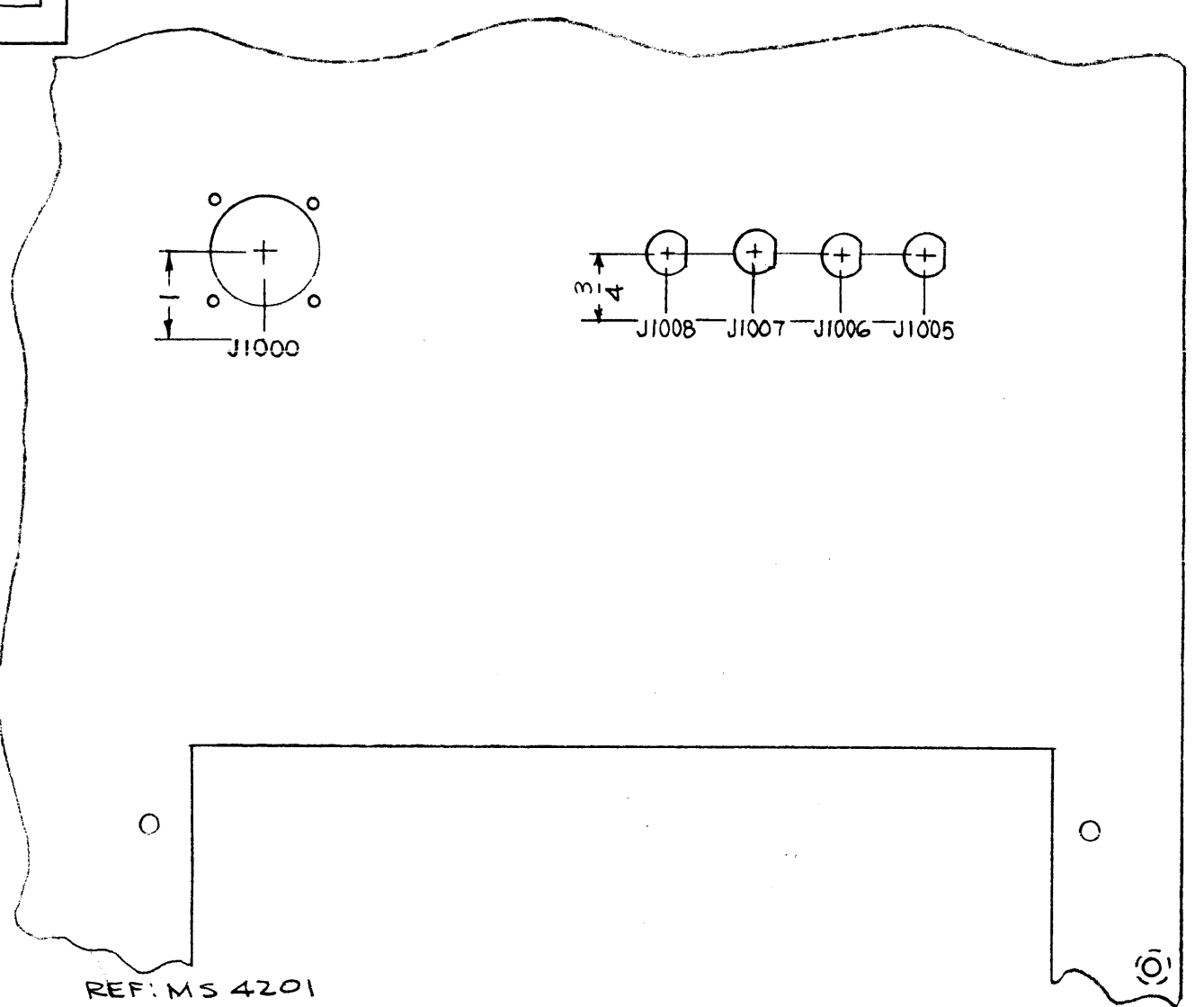
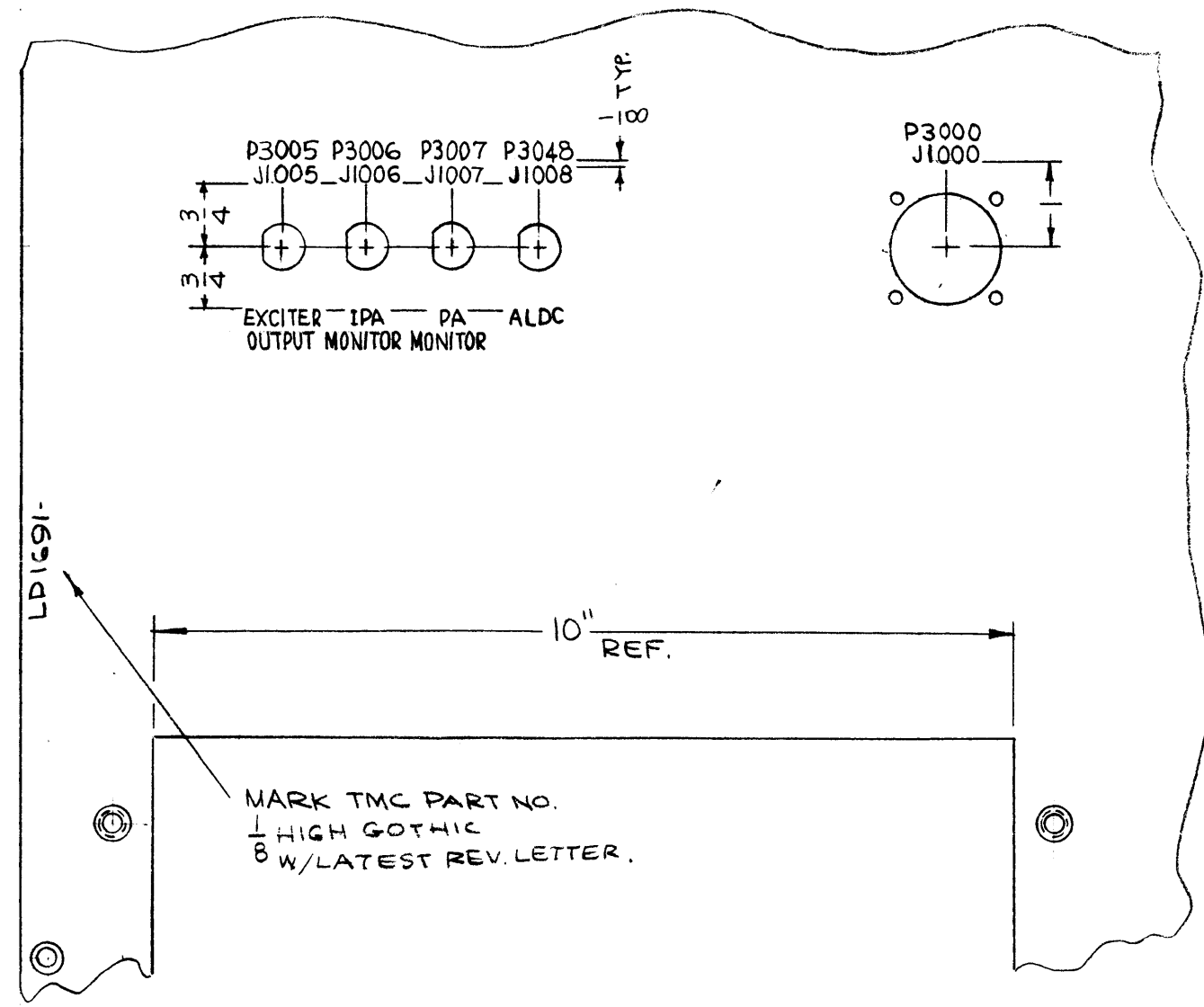

**MARKING PROCESS: AS PER TMC SPECIFICATION S-727.**  
**LETTERING: 1/8 HIGH BLACK GOTHIC, LOCATED AS SHOWN.**

1	GPT-10KLF	
Q'TY./UNIT	MODEL USED ON	ASS'Y. NO.
SCALE 1/2:1	CODE A	
THE CONTENTS OF THIS DRAWING ARE THE EXCLUSIVE PROPERTY OF THE TECHNICAL MATERIEL CORP. ITS UNAUTHORIZED USE OR REPRODUCTION IN WHOLE OR IN PART IS STRICTLY FORBIDDEN.		

REF: MS 4201

REQ'D.	ITEM	PART NUMBER	DESCRIPTION	SYMBOL
<b>F. BUDETTI LIST OF MATERIAL</b>				
MATERIAL		THE TECHNICAL MATERIEL CORP. MAMARONECK, NEW YORK		
FINISH		TITLE MARKING, SHIELD, LEFT SIDE MARKING PROCESS: AS PER TMC SPEC. S-727		
UNLESS OTHERWISE SPECIFIED DIMENSIONS ARE IN INCHES AND INCLUDE CHEMICALLY APPLIED OR PLATED FINISHES		DRAWN <i>[Signature]</i>	DATE 11-1-65	FINAL APPROVAL <i>[Signature]</i>
DECIMALS .X ± .05 .XX ± .01 .XXX ± .005		CHECKED <i>[Signature]</i>	DATE 12-28-65	
FRACTIONS ± 1/64 ANGLES ± 0° 30'		ELECT. DES. <i>[Signature]</i>	DATE	
TOLERANCES		MECH. DES. <i>[Signature]</i>	DATE	
NOTES		SHEET		REV. LTR.
		LD1691		Ø
		M/L ZS		

LD1670

REVISIONS

SYM	DESCRIPTION	DATE	E.M.N. NO.	DRAFT	CHKD	APPD
Ø	ORIGINAL RELEASE FOR PRODUCTION	3-31-66	Ø	WU		

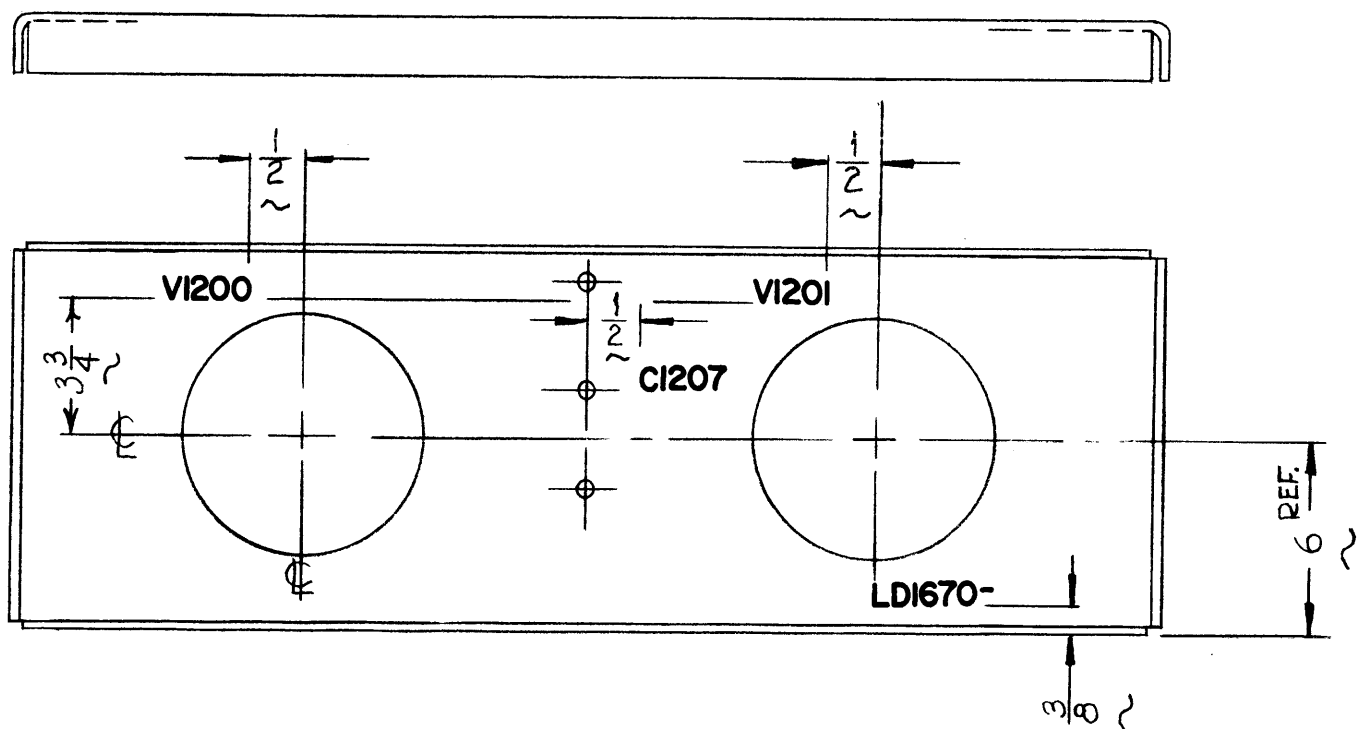
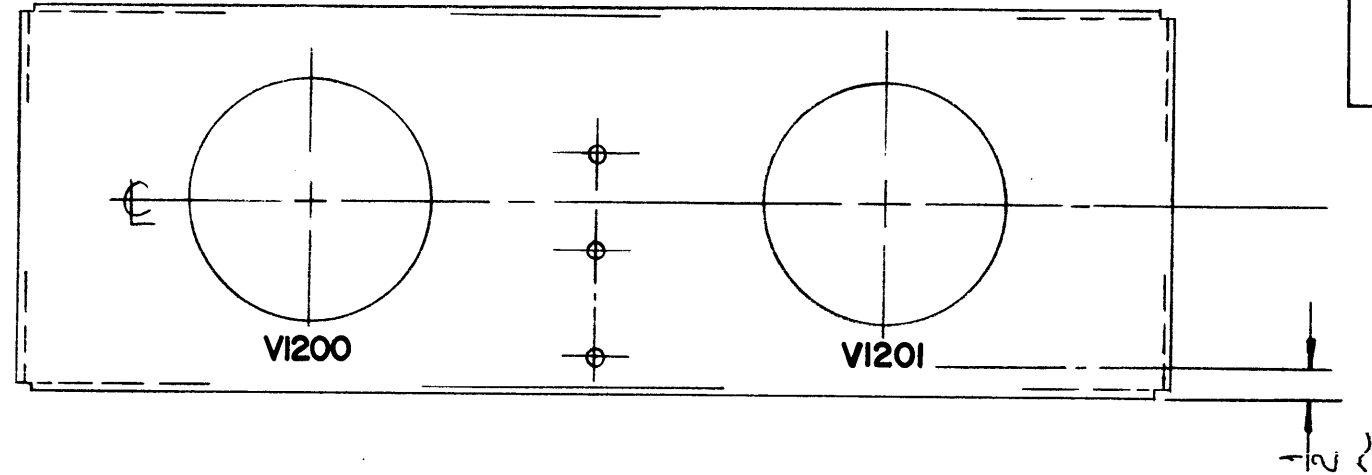

NOTES  
 1- MARKING PROCESS: PER TMC SPEC 9727  
 2- ALL LETTERING 1/8 HIGH BLACK GOTHIC

REF: M54159

REQ'D.	ITEM	PART NUMBER	DESCRIPTION	SYMBOL
<b>LIST OF MATERIAL</b>				
MATERIAL		THE TECHNICAL MATERIEL CORP. MAMARONECK, NEW YORK		
FINISH		TITLE MARKING, TOP COVER WRAPAROUND CHASSIS		
UNLESS OTHERWISE SPECIFIED DIMENSIONS ARE IN INCHES AND INCLUDE CHEMICALLY APPLIED OR PLATED FINISHES		DRAWN WU	DATE 3-23-66	FINAL APPROV M. Klein
DECIMALS .X ± .05 .XX ± .01 .XXX ± .005		CHECKED JCS	DATE 3/28/66	DATE 3/31/66
FRACTIONS ± 1/64 ANGLES ± 0° 30'		ELECT. DES. JCS	DATE 3-29-66	REV. LTR. Ø
TOLERANCES		MECH. DES.	DATE	SHEET

GPT-10KLF	
Q'TY./UNIT	MODEL USED ON
SCALE	ASS'Y. NO.
#	
CODE	

**NOTES**  
 THE CONTENTS OF THIS DRAWING ARE THE EXCLUSIVE PROPERTY OF THE TECHNICAL MATERIEL CORP. ITS UNAUTHORIZED USE OR REPRODUCTION IN WHOLE OR IN PART IS STRICTLY FORBIDDEN.

LD1671

REVISIONS					
SYM	DESCRIPTION	DATE	E.M.N. NO.	DRAFT	CHKD APPD
X1	CUTOUTS WERE HOLES 3/4 WAS 2 1/2	11-6-65	X1	SKY	MS
X2	DWG. WAS Ø SIZE, LD1671 WAS LD1671 / MS4163	12-21-65	X2	G.D.L.	
X3	M1200, M1201 DELETED	12-22-65		Jc	MD
Ø	ORIGINAL RELEASE FOR PRODUCTION	12-22-65		Jc	

**MARKING PROCESS: AS PER TMC SPECIFICATION S-727.**  
**LETTERING: 1/8 HIGH BLACK GOTHIC, LOCATED AS SHOWN.**

MARK TMC PART NO. WITH LATEST REVISION LETTER.

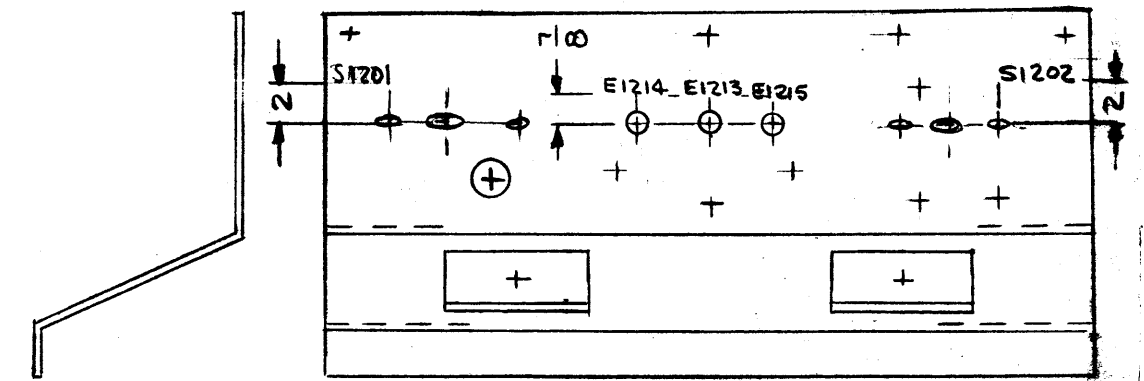
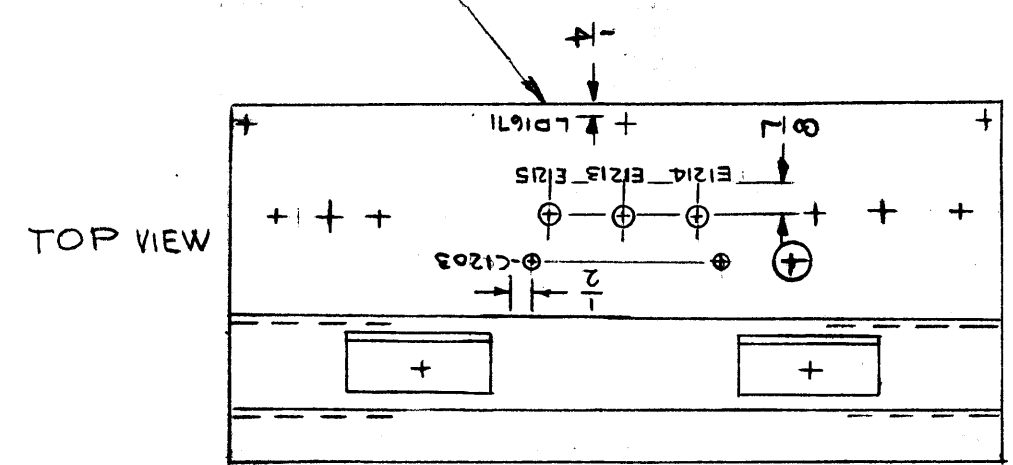

REF: 4163

REQ'D.	ITEM	PART NUMBER	DESCRIPTION	SYMBOL
<b>BUDETTI LIST OF MATERIAL</b>				
MATERIAL		<b>THE TECHNICAL MATERIEL CORP. MAMARONECK, NEW YORK</b>		
FINISH		TITLE <b>MARKING, BAND SWITCH CHASSIS</b>		
UNLESS OTHERWISE SPECIFIED DIMENSIONS ARE IN INCHES AND INCLUDE CHEMICALLY APPLIED OR PLATED FINISHES		DRAWN G.D.L.	DATE 12-21-65	FINAL APPROVAL <i>[Signature]</i>
DECIMALS .X ± .05 .XX ± .01 .XXX ± .005		CHECKED JCB	DATE 12-21-65	DATE 12/22/65
FRACTIONS ± 1/64 ANGLES ± 0° 30'		ELECT. DES. <i>[Signature]</i>	DATE	DATE
TOLERANCES		MECH. DES. <i>[Signature]</i>	DATE	DATE
		M/L <i>[Signature]</i>	DATE 12/22/65	DATE
				LD1671
				Ø
				REV. LTR.

1	GPT-10KLF	
Q'TY./UNIT	MODEL USED ON	ASS'Y. NO.
SCALE	CODE A	
THE CONTENTS OF THIS DRAWING ARE THE EXCLUSIVE PROPERTY OF THE TECHNICAL MATERIEL CORP. ITS UNAUTHORIZED USE OR REPRODUCTION IN WHOLE OR IN PART IS STRICTLY FORBIDDEN.		

NOTES

LD1673

REVISIONS

SYM	DESCRIPTION	DATE	EM N NO	DRAFT	CHKD	APPD
X1	DWG. WAS ① SIZE, LD1673- WAS LD1673-/MS4162-	12-21-65	X1	G.D.L.		
Ø	ORIGINAL RELEASE FOR PRODUCTION	12-22-65	M	JC		

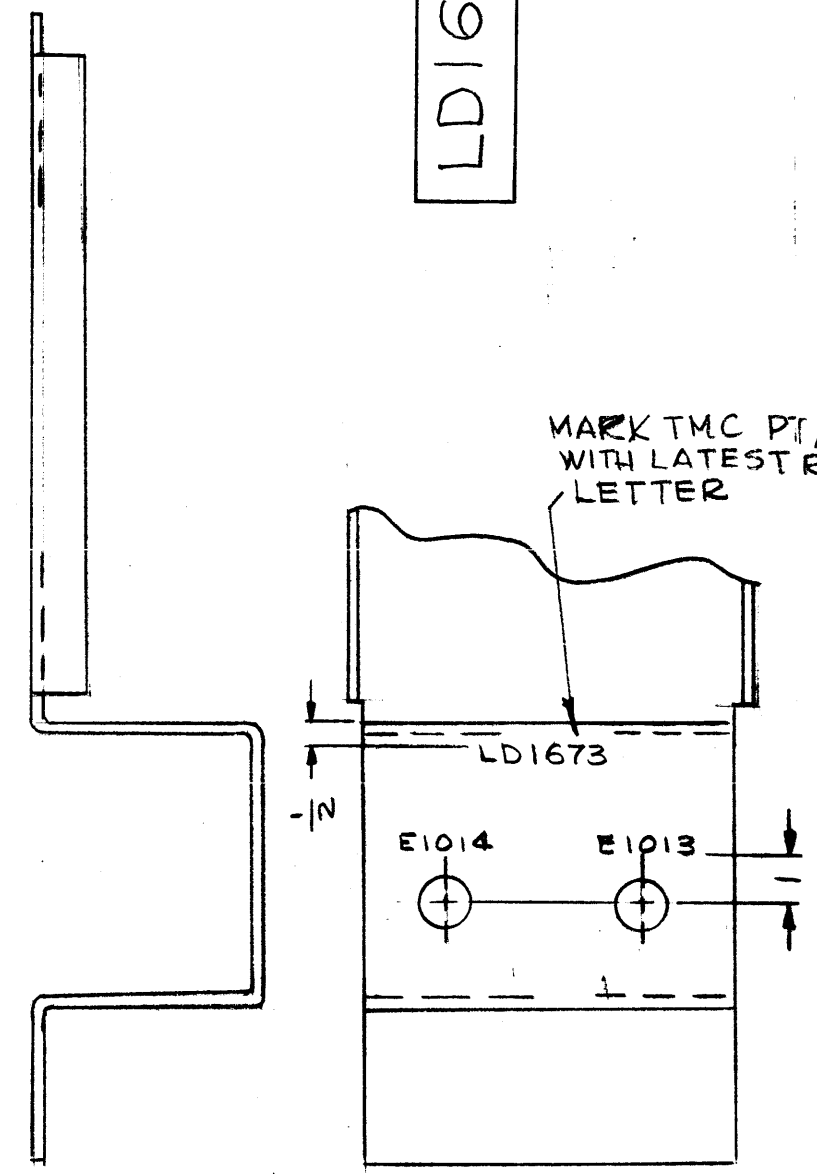
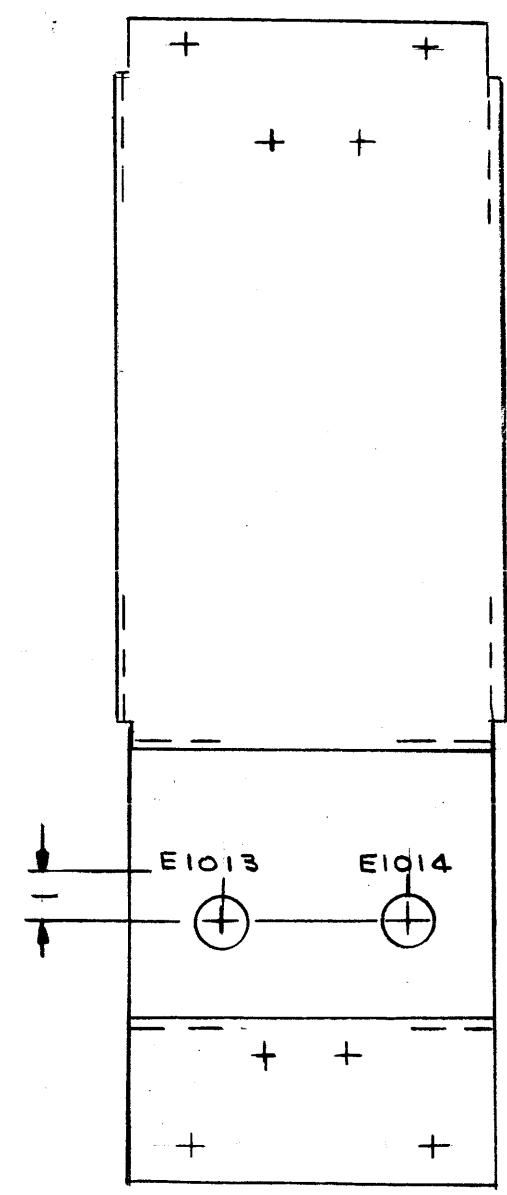

MARKING PROCESS: AS PER TMC SPECIFICATION S-727.  
 LETTERING: 1/8 HIGH BLACK GOTHIC, LOCATED AS SHOWN.

REF: MS4162

1	GPT-10KLF	
QTY./UNIT	MODEL USED ON	ASS'Y. NO.
SCALE	CODE	
	A	

THE CONTENTS OF THIS DRAWING ARE THE EXCLUSIVE PROPERTY OF THE TECHNICAL MATERIEL CORP. ITS UNAUTHORIZED USE OR REPRODUCTION IN WHOLE OR IN PART IS STRICTLY FORBIDDEN.

REQ'D.	ITEM	PART NUMBER	DESCRIPTION	SYMBOL
<b>BUDETTI LIST OF MATERIAL</b>				
MATERIAL			<b>THE TECHNICAL MATERIEL CORP. MAMARONECK, NEW YORK</b>	
FINISH			TITLE MARKING, RF CONNECTOR PLATE	
UNLESS OTHERWISE SPECIFIED DIMENSIONS ARE IN INCHES AND INCLUDE CHEMICALLY APPLIED OR PLATED FINISHES			DRAWN G.D.L.	DATE 12-21-65
DECIMALS .X ± .05 .XX ± .01 .XXX ± .005			CHECKED JCK	DATE 12-21-65
FRACTIONS ± 1/64 ANGLES ± 0° 30'			ELECT. DES.	DATE
TOLERANCES			MECH. DES.	DATE
			M/L	12/22/65
			FINAL APPROVAL <i>[Signature]</i> LD1673	
			DATE 12/22/65	
			SHEET	
			REV. LTR.	

NOTES

SYM	DESCRIPTION	REVISIONS				
		DATE	E.M.N. NO.	DRAFT	CHKD	APPD
X	EXP. RELEASE	2/13/65		JL		
X1	MARKING WAS BLACK, L1201, L1204, R1204, R1205 RE-LOCATED	12-21-65	X1	<i>MR</i>		<i>W</i>
Ø	ORIGINAL RELEASE FOR PRODUCTION	12-22-65	<del>#</del>	Jc		

LD1674

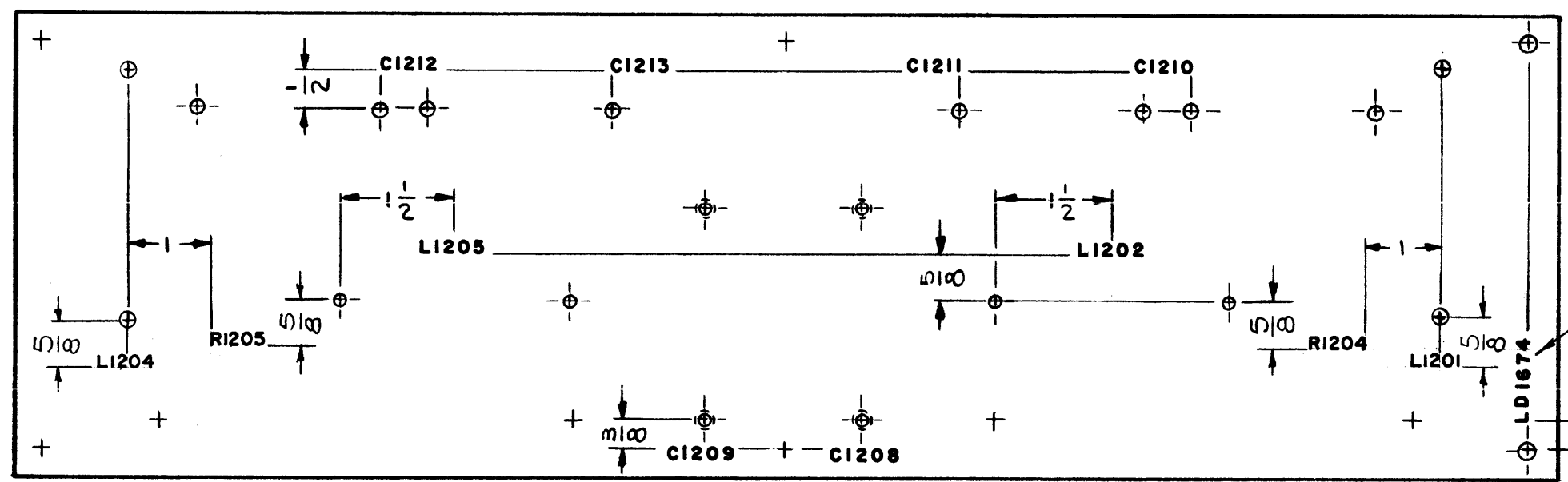

MARK TMC PART NO. 1/8  
HIGH BLACK GOTHIC  
W/LATEST REVISION  
LETTER

- UNLESS OTHERWISE SPECIFIED -
- 1-MARKING PROCESS AS PER TMC SPEC S727.
  - 2-ALL LETTERING TO BE 1/8 HIGH WHITE GOTHIC.

REF : PX 872

1	GPT-10KLF	
Q'TY./UNIT	MODEL USED ON	ASS'Y. NO.
SCALE	CODE	
1/2		
THE CONTENTS OF THIS DRAWING ARE THE EXCLUSIVE PROPERTY OF THE TECHNICAL MATERIEL CORP. ITS UNAUTHORIZED USE OR REPRODUCTION IN WHOLE OR IN PART IS STRICTLY FORBIDDEN.		

REQ'D.	ITEM	PART NUMBER	DESCRIPTION	SYMBOL
LIST OF MATERIAL				
MATERIAL		THE TECHNICAL MATERIEL CORP. MAMARONECK, NEW YORK		
FINISH		TITLE MARKING, PA COMPARTMENT BOARD		
UNLESS OTHERWISE SPECIFIED DIMENSIONS ARE IN INCHES AND INCLUDE CHEMICALLY APPLIED OR PLATED FINISHES		DRAWN J. LESHINSKI	DATE 2/13/65	FINAL APPROVAL <i>[Signature]</i>
DECIMALS .X ± .05 .XX ± .01 .XXX ± .005		CHECKED <i>[Signature]</i>	DATE 6-24-65	DATE 12/22/65
FRACTIONS ± 1/64 ANGLES ± 0° 30'		ELECT. DES. <i>[Signature]</i>	DATE	REV. LTR. Ø
TOLERANCES		MECH. DES. <i>[Signature]</i>	DATE	
		M/L <i>[Signature]</i>	DATE 12/22/65	

NOTES



REVISIONS					
SYM	DESCRIPTION	DATE	E.M.N. NO.	DRAFT	CHKD APPD
Ø	ORIGINAL RELEASE FOR PRODUCTION	12/21/65	Ø		JLB

LD1675

MARK TMC P/N. (LD1675.)  
 1/8 HIGH GOTHIC W/LATEST  
 REV. LETTER, ON REAR.

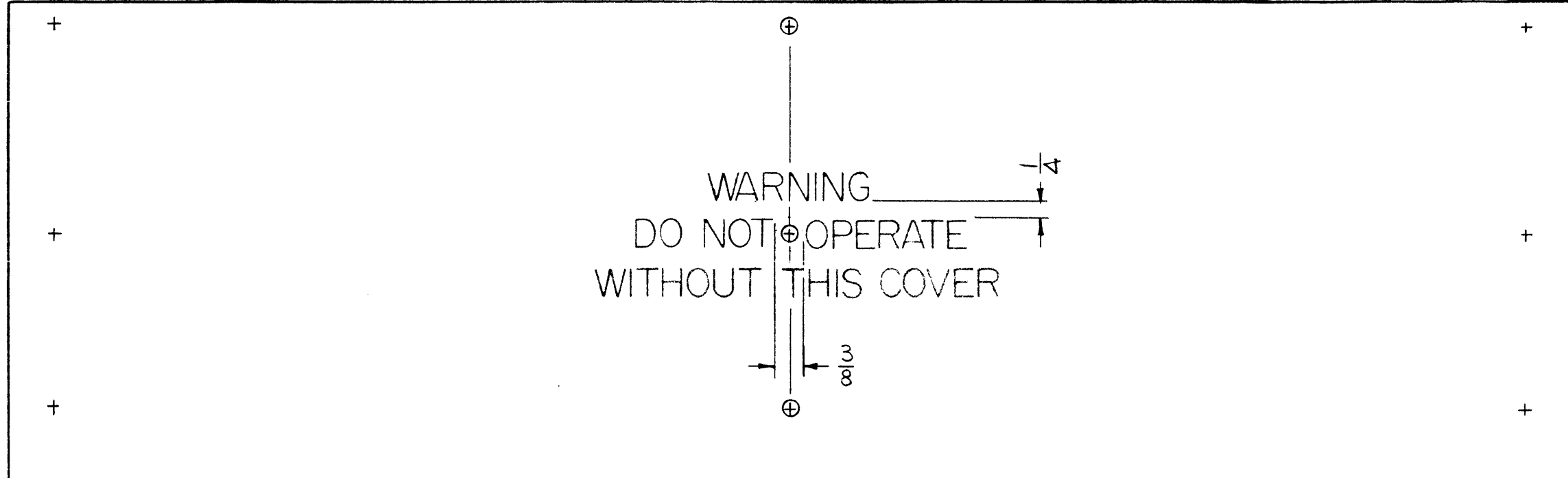

FRONT VIEW

MARKING PROCESS: AS PER TMC SPECIFICATION S-727.  
 LETTERING: 1/2 HIGH RED GOTHIC, LOCATED AS SHOWN.

REF: MS4158.

1	GPT-10KLF	
Q'TY./UNIT	MODEL USED ON	ASS'Y. NO.
SCALE 1/2:1	CODE A	

NOTES

THE CONTENTS OF THIS DRAWING ARE THE EXCLUSIVE PROPERTY OF THE TECHNICAL MATERIEL CORP. ITS UNAUTHORIZED USE OR REPRODUCTION IN WHOLE OR IN PART IS STRICTLY FORBIDDEN.

REQ'D.	ITEM	PART NUMBER	DESCRIPTION	SYMBOL
F. BUDETTI LIST OF MATERIAL				
MATERIAL		THE TECHNICAL MATERIEL CORP. MAMARONECK, NEW YORK		
FINISH		TITLE MARKING, PLATE, REAR WRAP AROUND CHASSIS MARKING PROCESS: AS PER TMC SPEC. S-727		
UNLESS OTHERWISE SPECIFIED DIMENSIONS ARE IN INCHES AND INCLUDE CHEMICALLY APPLIED OR PLATED FINISHES		DRAWN [Signature]	DATE 11-2-65	FINAL APPROVAL [Signature]
DECIMALS .X ± .05 .XX ± .01 .XXX ± .005		CHECKED [Signature]	DATE 12/20/65	DATE 12/20/65
FRACTIONS ± 1/64 ANGLES ± 0° 30'		ELECT. DES. [Signature]	DATE	REV. LTR. Ø
TOLERANCES		MECH. DES. [Signature]	DATE	SHEET
		ML [Signature]	12/22/65	REV. LTR.

LD 1682

REVISIONS

SYM	DESCRIPTION	DATE	E.M.N. NO.	DRAFT	CHKD	APPD
Ø	ORIGINAL RELEASE FOR PRODUCTION					

LETTERING 1/8" GOTHIC, WHITE AS PER S727

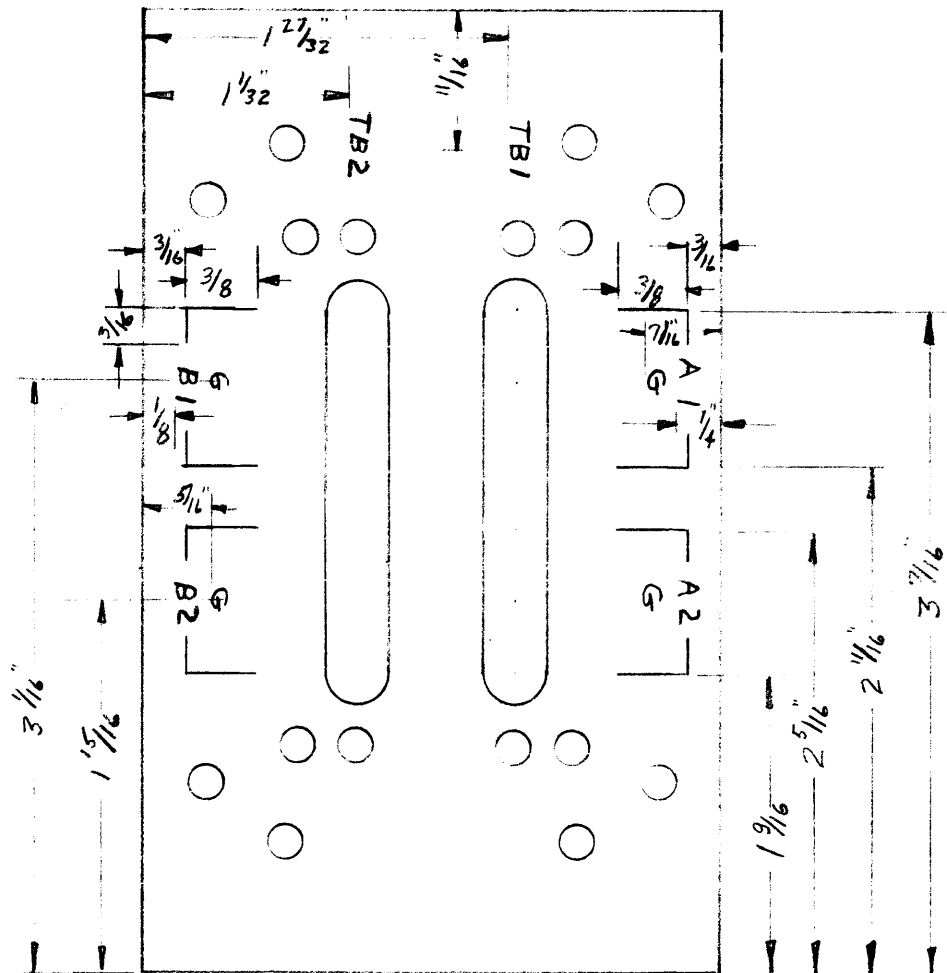

REF PX877

REQ'D.	ITEM	PART NUMBER	DESCRIPTION	SYMBOL
<b>LIST OF MATERIAL</b>				
MATERIAL		THE TECHNICAL MATERIEL CORP. MAMARONECK, NEW YORK		
FINISH		TITLE LETTERING, TERM. BD.		
UNLESS OTHERWISE SPECIFIED DIMENSIONS ARE IN INCHES AND INCLUDE CHEMICALLY APPLIED OR PLATED FINISHES		DRAWN BN	DATE	FINAL APPROVAL
		CHECKED JM	DATE 24 Sep 69	DATE 4/10/69
		ELECT. DES.	DATE	LD1682
		MECH. DES.	DATE	Ø
		SHEET		REV. LTR.

Q'TY./UNIT	MODEL USED ON	ASS'Y. NO.
1	RAK-20B	A 4076
SCALE	CODE	

THE CONTENTS OF THIS DRAWING ARE THE EXCLUSIVE PROPERTY OF THE TECHNICAL MATERIEL CORP. ITS UNAUTHORIZED USE OR REPRODUCTION IN WHOLE OR IN PART IS STRICTLY FORBIDDEN.

NOTES

MARKING PROCESS: AS PER TMC SPECIFICATION S-727.  
 LETTERING: 1/8 HIGH BLACK GOTHIC, LOCATED AS SHOWN.

REVISIONS					
SYM	DESCRIPTION	DATE	E.M.N. NO.	DRAFT	CHKD
Ø	ORIGINAL RELEASE FOR PRODUCTION	11-23-65	Ø	File	

LD1687

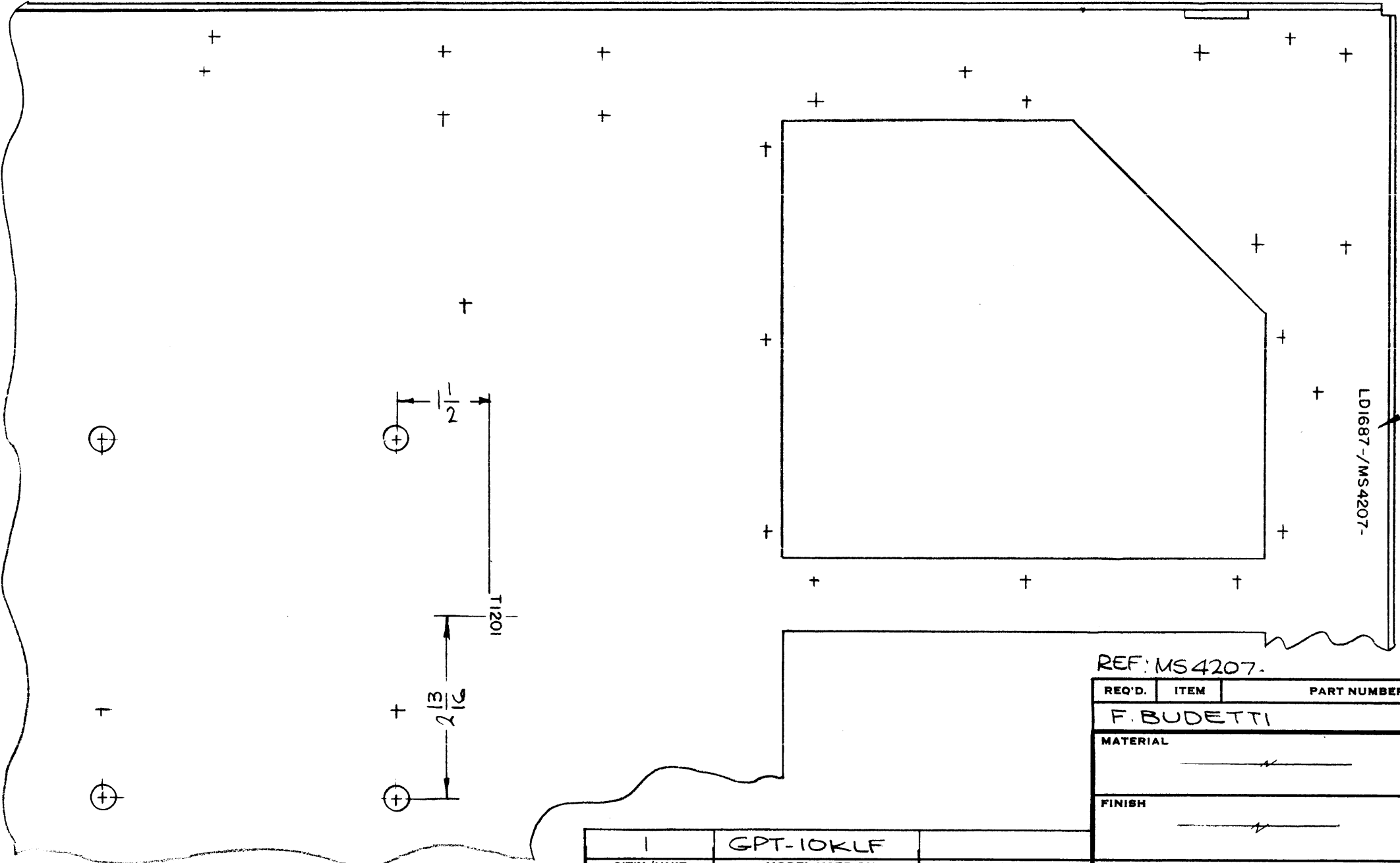

MARK TMC P/N  
 1/8 HIGH GOTHIC  
 W/LATEST REV.  
 LETTER.

REF: MS4207-

REQ'D.	ITEM	PART NUMBER	DESCRIPTION	SYMBOL
<b>F. BUDETTI LIST OF MATERIAL</b>				
MATERIAL			<b>THE TECHNICAL MATERIEL CORP.</b> MAMARONECK, NEW YORK	
FINISH			TITLE MARKING, SHIELD, TOP MAIN FRAME MARKING PROCESS: AS PER TMC SPEC. S-727	
UNLESS OTHERWISE SPECIFIED DIMENSIONS ARE IN INCHES AND INCLUDE CHEMICALLY APPLIED OR PLATED FINISHES		DRAWN <i>[Signature]</i>	DATE 11-9-65	FINAL APPROVAL <i>[Signature]</i>
DECIMALS .X ± .05 .XX ± .01 .XXX ± .005		TOLERANCES	DATE 11/23/65	DATE 11/23/65
FRACTIONS ± 1/64 ANGLES ± 0° 30'		ELECT. DES.	DATE	DATE
		MECH. DES.	DATE	DATE
			SHEET	REV. LTR.

1	GPT-10KLF	
QTY./UNIT	MODEL USED ON	ASS'Y. NO.
SCALE 1/2:1	CODE A	
THE CONTENTS OF THIS DRAWING ARE THE EXCLUSIVE PROPERTY OF THE TECHNICAL MATERIEL CORP. ITS UNAUTHORIZED USE OR REPRODUCTION IN WHOLE OR IN PART IS STRICTLY FORBIDDEN.		

NOTES

LD1692

REVISIONS

SYM	DESCRIPTION	DATE	FM N NO	DRAFT	CHKD	APPD
X1	REDRAWN FROM 1 SIZE, ADDED S1203, S1204	12-21-65	X1			
Ø	ORIGINAL RELEASE FOR PRODUCTION	12/21/65	Ø			

MARK TMC P/N'S  
1/8 HIGH GOTHIC  
W/LATEST REV.  
LETTER

MARK TMC P/N'S  
1/8 HIGH GOTHIC  
W/LATEST REV.  
LETTER.

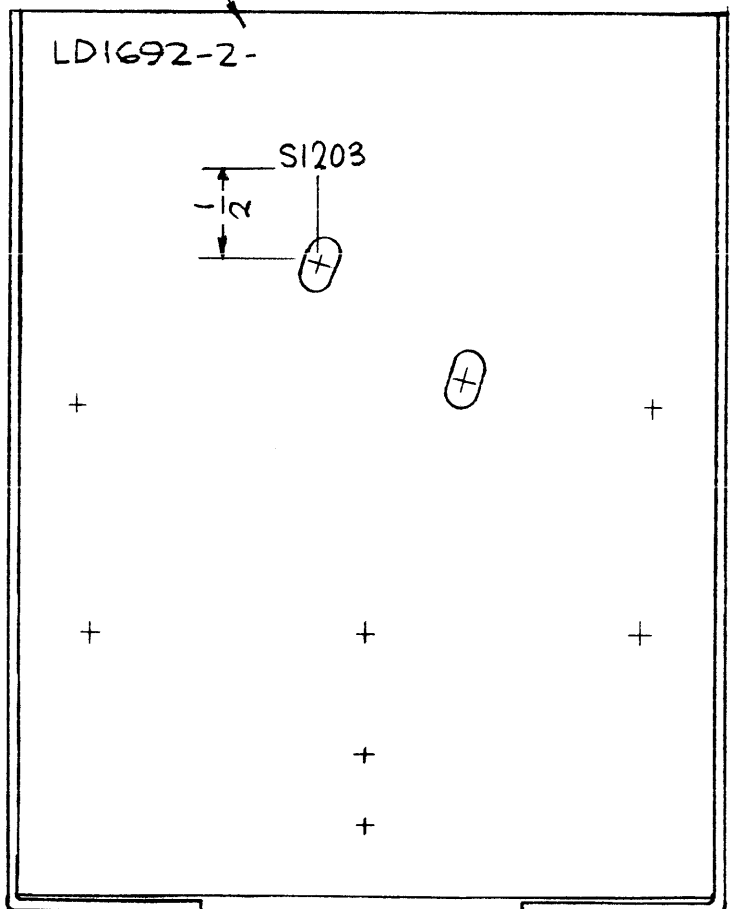
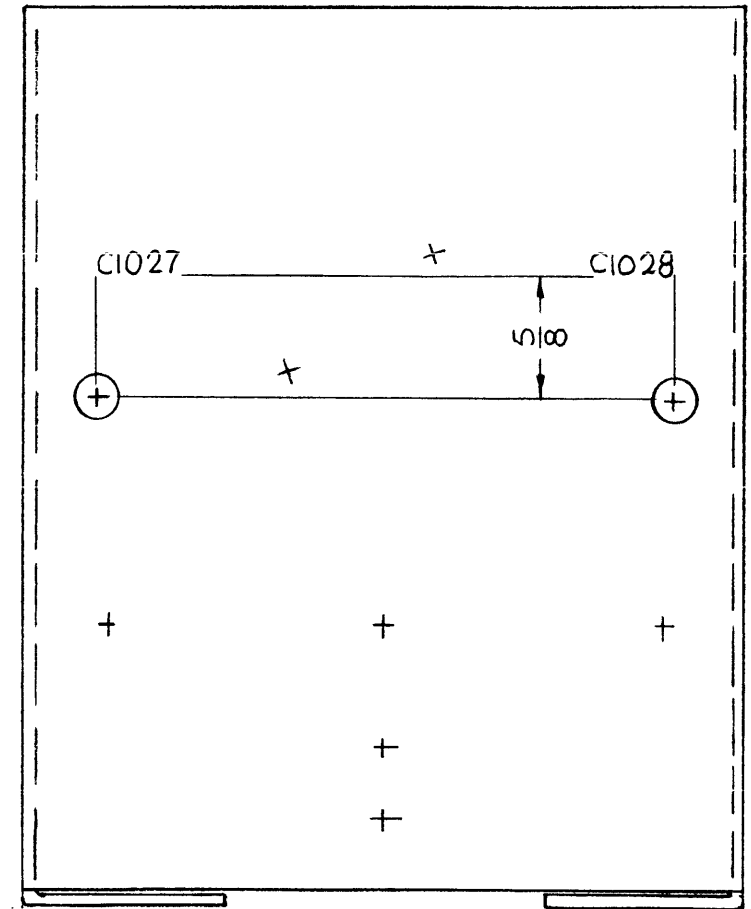
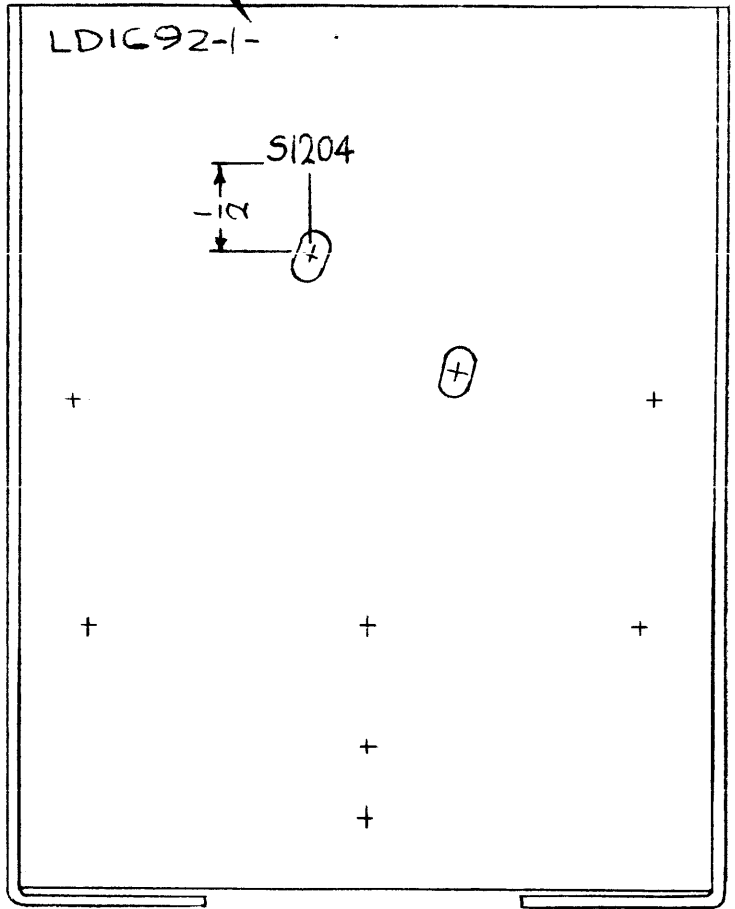
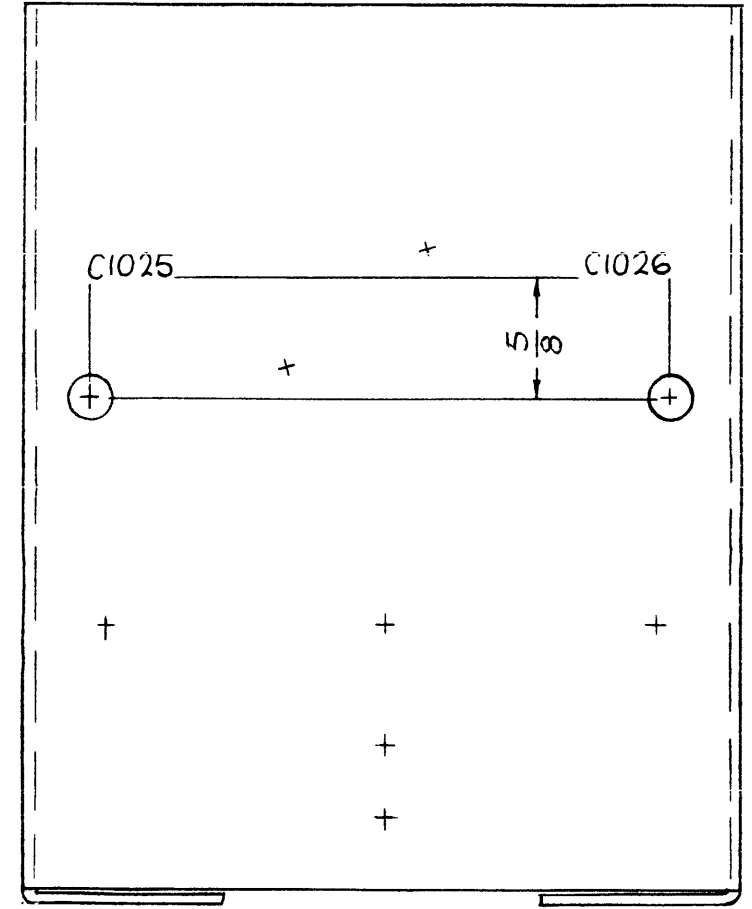

FRONT VIEW

LD1692-1

REAR VIEW

FRONT VIEW

LD1692-2

REAR VIEW

MARKING PROCESS: AS PER TMC SPECIFICATION S-727.

LETTERING: 1/8 HIGH BLACK GOTHIC, LOCATED AS SHOWN.

REF: MS 4199

REQ'D.	ITEM	PART NUMBER	DESCRIPTION	SYMBOL
--------	------	-------------	-------------	--------

F. BUDETTI LIST OF MATERIAL

MATERIAL \_\_\_\_\_ THE TECHNICAL MATERIEL CORP.  
FINISH \_\_\_\_\_ MAMARONECK, NEW YORK

TITLE MARKING, BRKT DETENT SWITCH  
MARKING PROCESS: AS PER TMC SPEC. S-727

UNLESS OTHERWISE SPECIFIED  
DIMENSIONS ARE IN INCHES AND INCLUDE  
CHEMICALLY APPLIED OR PLATED FINISHES

DECIMALS .X ± .05 .XX ± .01 .XXX ± .005  
FRACTIONS ± 1/64 ANGLES ± 0° 30'  
TOLERANCES

DRAWN	DATE	FINAL APPROVAL	DATE
CHECKED	DATE		
ELECT. DES.	DATE		
MECH. DES.	DATE		

1 EA	GPT-10KLF	
Q'TY./UNIT	MODEL USED ON	ASS'Y. NO.
SCALE	CODE	
!!!	A	

NOTES

THE CONTENTS OF THIS DRAWING ARE THE EXCLUSIVE PROPERTY OF THE TECHNICAL MATERIEL CORP. ITS UNAUTHORIZED USE OR REPRODUCTION IN WHOLE OR IN PART IS STRICTLY FORBIDDEN.

DATE 12/22/65 SHEET REV. LTR.