

REVISIONS							
ZONE	SYM	DESCRIPTION	DATE	E.M.N. NO.	DRAFT	CHKD	APPD
-	X	EXPERIMENTAL RELEASE	11.6.64	-	JNB		
	X1	ON TB101 NO 5 WAS GND	1-5-65	X1	SPG		
	Ø	ORIGINAL RELEASE FOR PRODUCTION	4/22/69		CU		

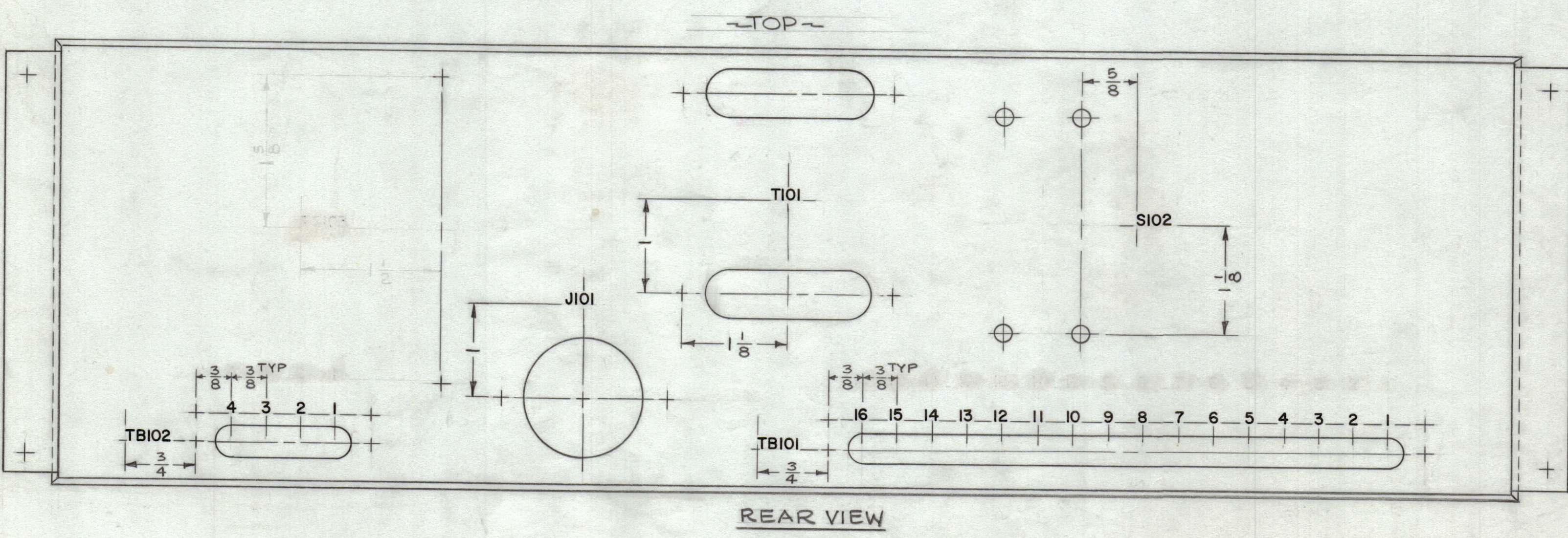
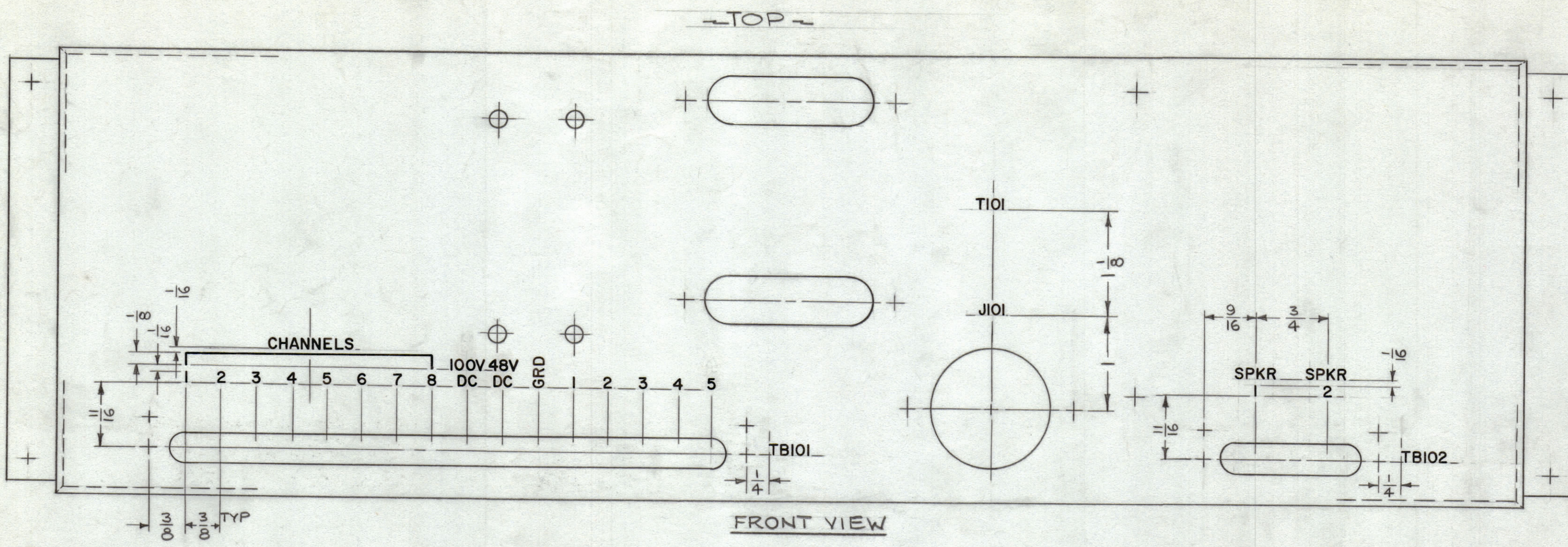

MARKING PROCESS: AS PER TMC SPECIFICATION S-727.  
 LETTERING: 1/8 HIGH BLACK GOTHIC, LOCATED AS SHOWN.

1	LSP-6X	
Q'TY./UNIT	MODEL USED ON	ASS'Y. NO.
SCALE	CODE	
1:1	A	

THE CONTENTS OF THIS DRAWING ARE THE EXCLUSIVE PROPERTY OF THE TECHNICAL MATERIEL CORP. ITS UNAUTHORIZED USE OR REPRODUCTION IN WHOLE OR IN PART IS STRICTLY FORBIDDEN.

REF: M54116

REQ'D.	ITEM	PART NUMBER	DESCRIPTION	SYMBOL
LIST OF MATERIAL				
MATERIAL		THE TECHNICAL MATERIEL CORP. MAMARONECK, NEW YORK		
FINISH		TITLE MARKING, CHASSIS, POWER SUPPLY MARKING PROCESS: TMC S727		
UNLESS OTHERWISE SPECIFIED DIMENSIONS ARE IN INCHES AND INCLUDE CHEMICALLY APPLIED OR PLATED FINISHES		DRAWN	DATE	FINAL APPROVAL
DECIMALS .X ± .05 .XX ± .01 .XXX ± .005		11.6.64	11-12-64	SPM 4/22/69
FRACTIONS ± 1/64 ANGLES ± 0° 30'		CHECKED	DATE	
TOLERANCES		MECH. DES.	DATE	

NOTES

LD1645 Ø