

REVISIONS							
ZONE	SYM	DESCRIPTION	DATE	E.M.N. NO.	DRAFT	CHKD	APPD
	0	ORIGINAL RELEASE FOR PRODUCTION	3/2/64		A.M.		

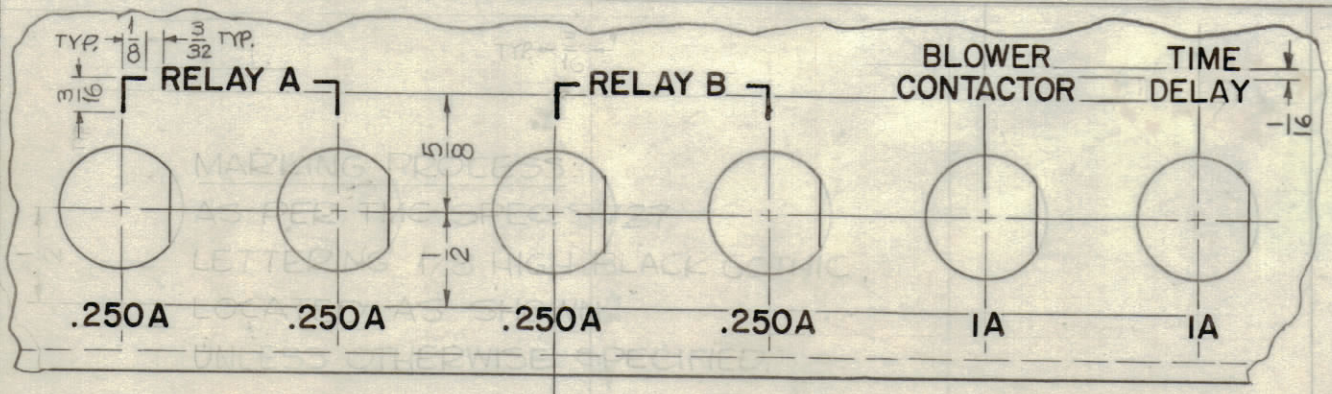
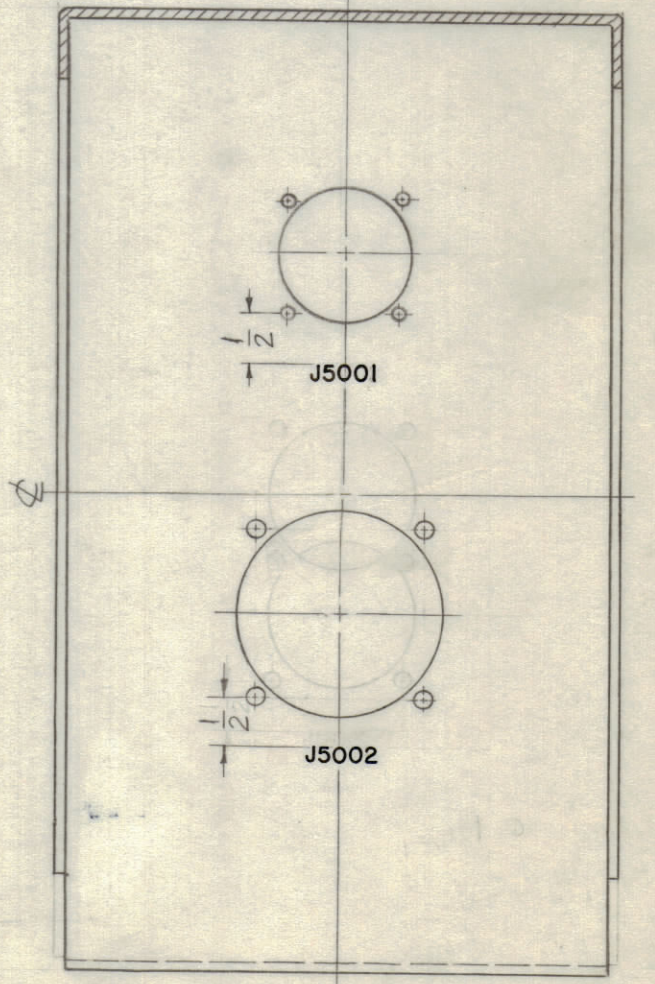
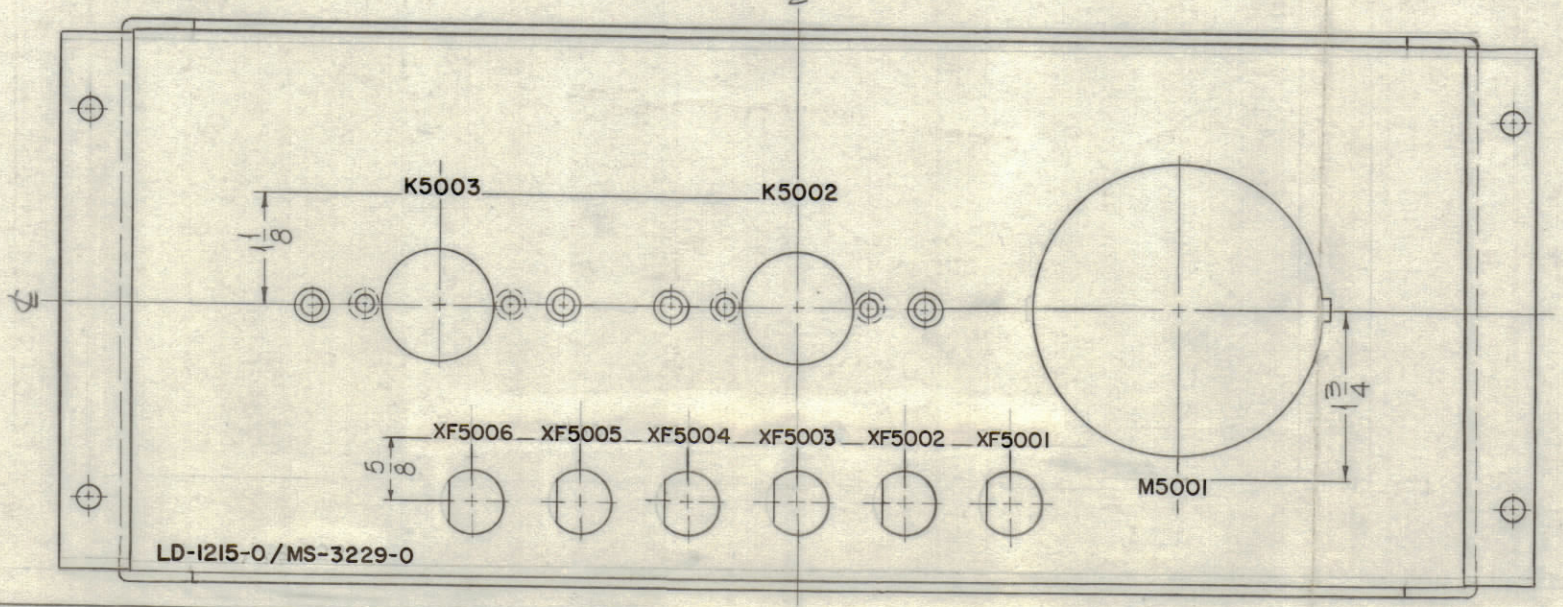
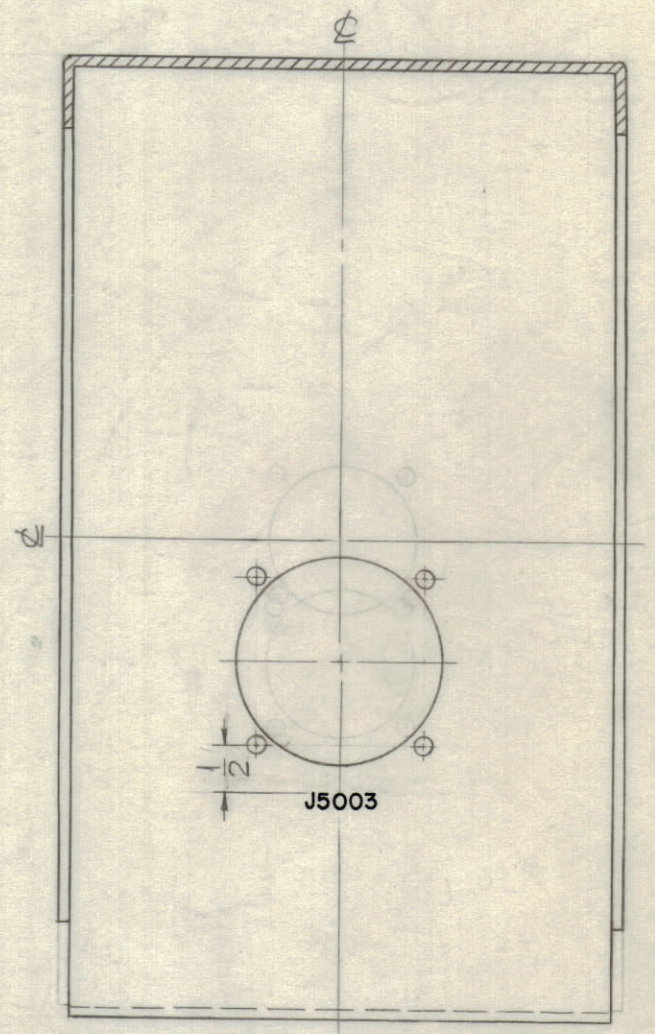
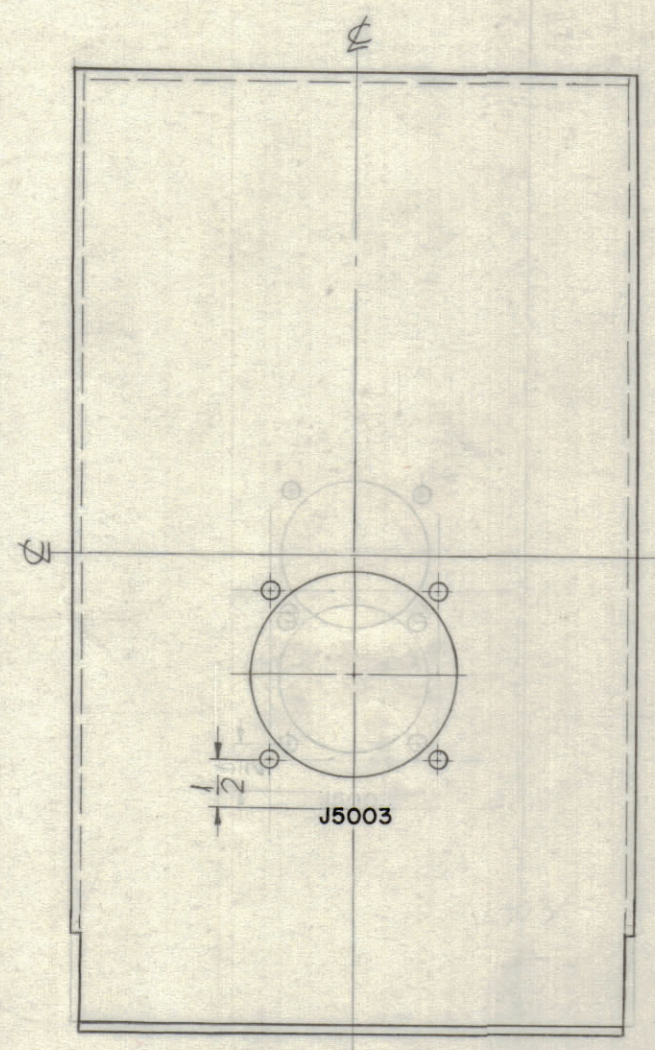
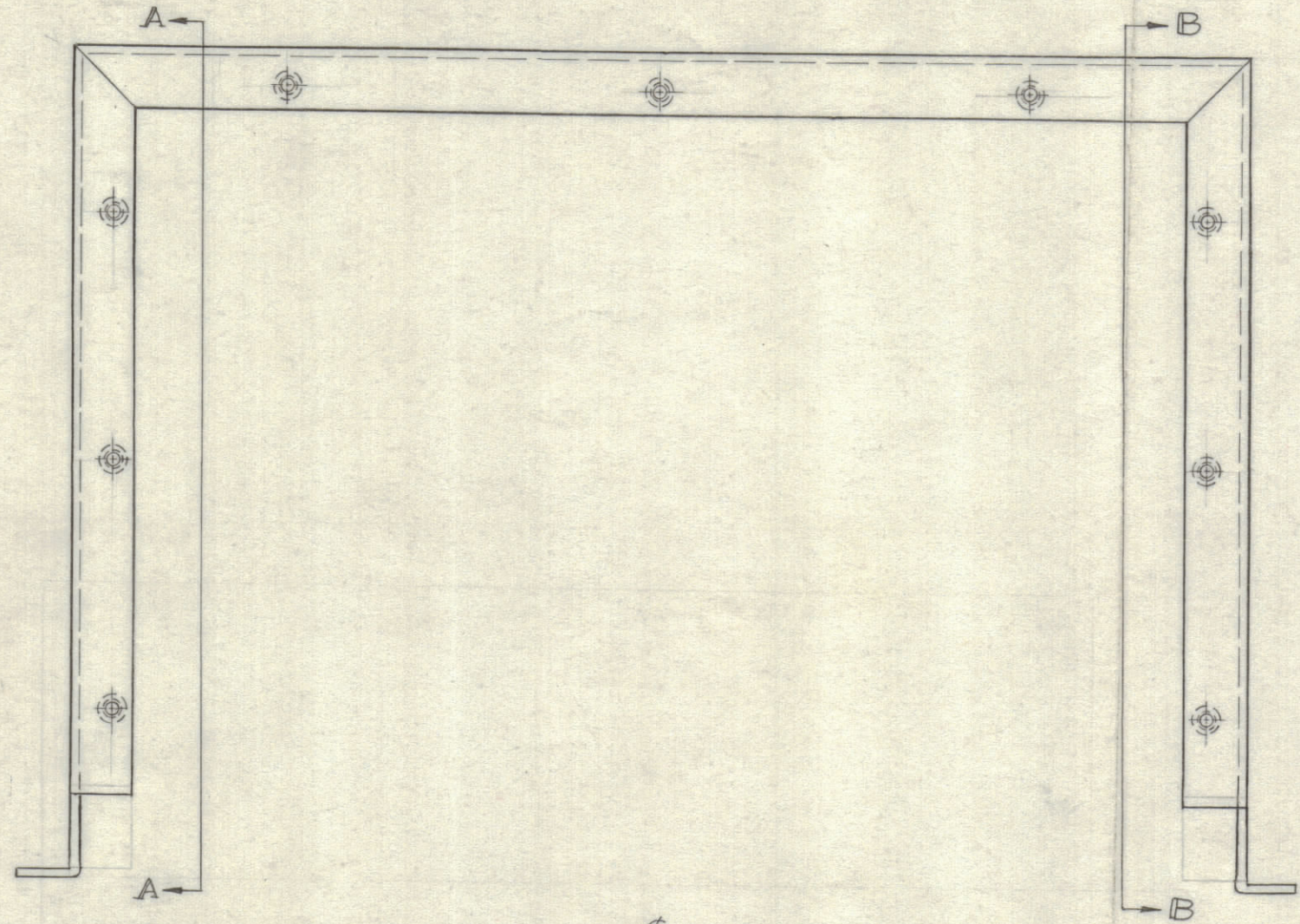
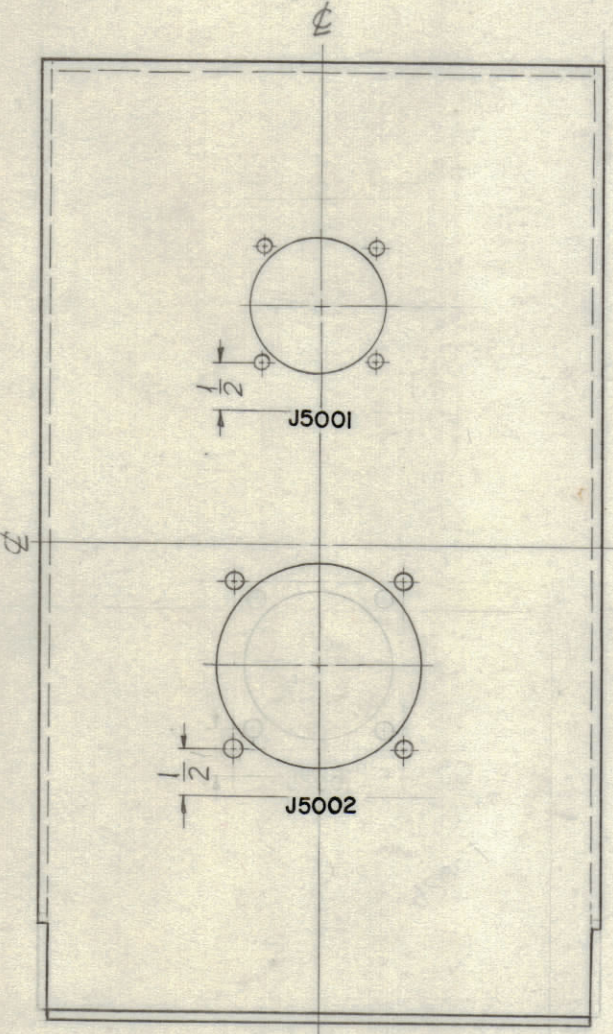
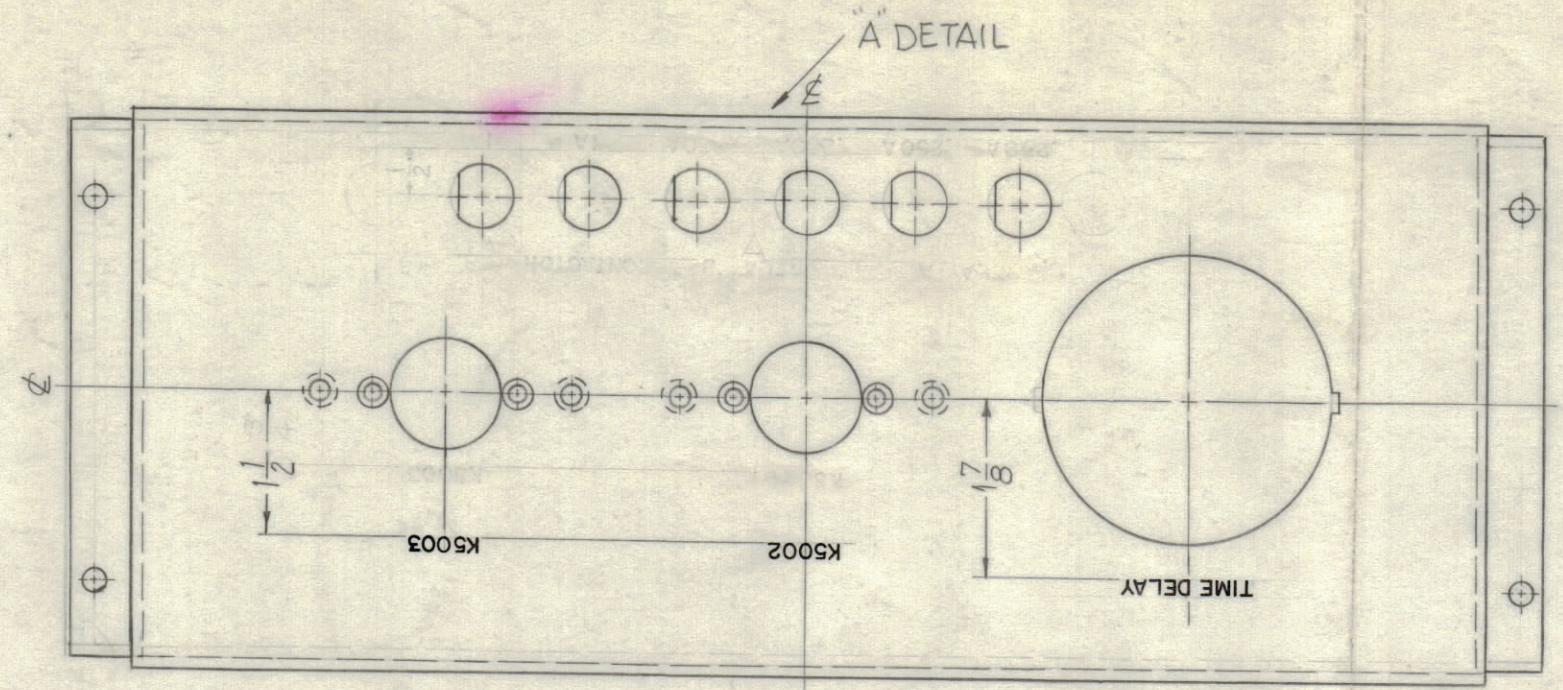

MARKING PROCESS: AS PER TMC SPECIFICATION S-727.  
 LETTERING: 1/8 HIGH BLACK GOTHIC, LOCATED AS SHOWN. (INSIDE)  
 LETTERING: 1/8 HIGH WHITE GOTHIC, LOCATED AS SHOWN. (OUTSIDE)  
 UNLESS OTHERWISE SPECIFIED.

NOTES

1	GPT-200K	AX-393
Q'TY./UNIT	MODEL USED ON	ASS'Y. NO.
SCALE	CODE	
	A	

THE CONTENTS OF THIS DRAWING ARE THE EXCLUSIVE PROPERTY OF THE TECHNICAL MATERIEL CORP. ITS UNAUTHORIZED USE OR REPRODUCTION IN WHOLE OR IN PART IS STRICTLY FORBIDDEN.

REQ'D.	ITEM	PART NUMBER	DESCRIPTION	SYMBOL
F. BUDETTI				
LIST OF MATERIAL				
THE TECHNICAL MATERIEL CORP. MAMARONECK, NEW YORK				
TITLE: MARKING CHASSIS, BLOWER DELAY MARKING METHOD: AS PER TMC SPEC S-727				
UNLESS OTHERWISE SPECIFIED DIMENSIONS ARE IN INCHES AND INCLUDE CHEMICALLY APPLIED OR PLATED FINISHES		DRAWN	DATE	FINAL APPROVAL
DECIMALS .X ± .05 .XX ± .01 .XXX ± .005		SRG	5-14-63	
FRACTIONS ± 1/64 ANGLES ± 0° 30'		CHEKED	DATE	
TOLERANCES		205	4/14/64	
		ELECT. DES.	DATE	
		MECH. DES.	DATE	
		LD	2-14-64	
SHEET				REV. LTR.

LD-1215 0