

LD-1179	REVISIONS						
	SYM	DESCRIPTION	DATE	E.M.N. NO.	DRAFT	CHKD	APPD
0	ORIGINAL RELEASE FOR PRODUCTION		3-2-64		A.M.		

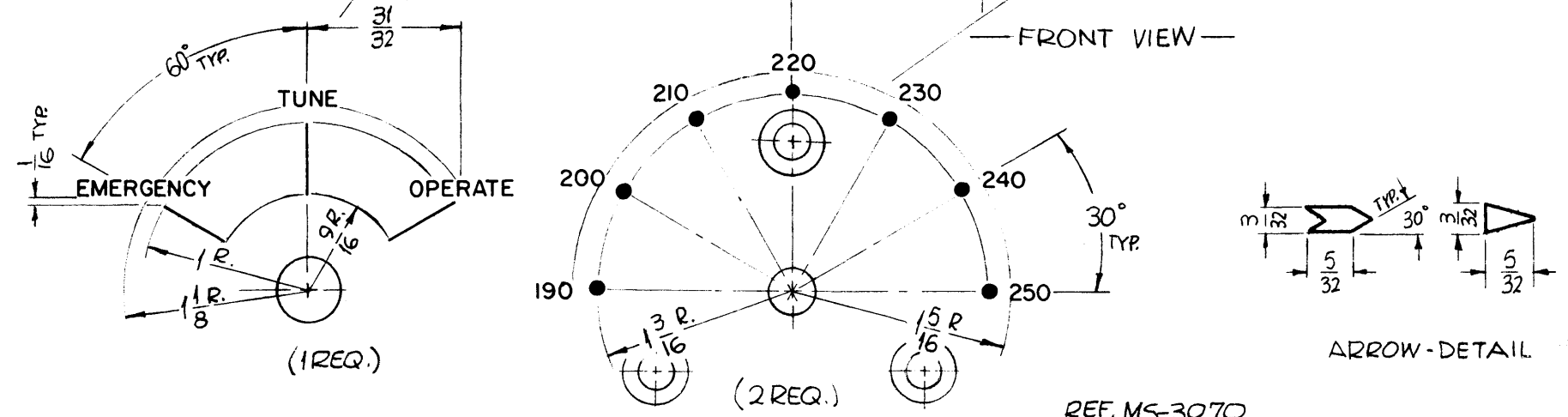
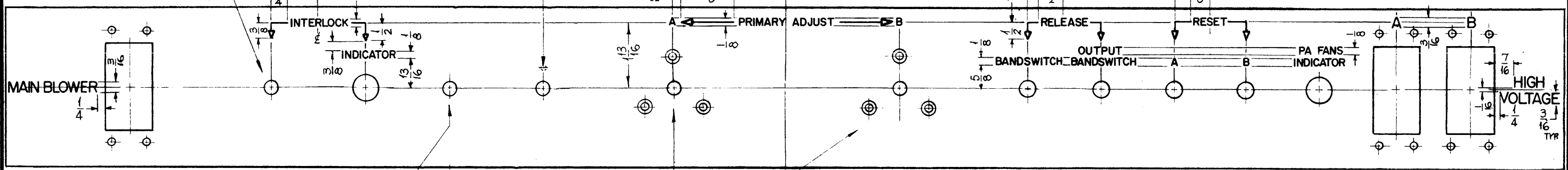
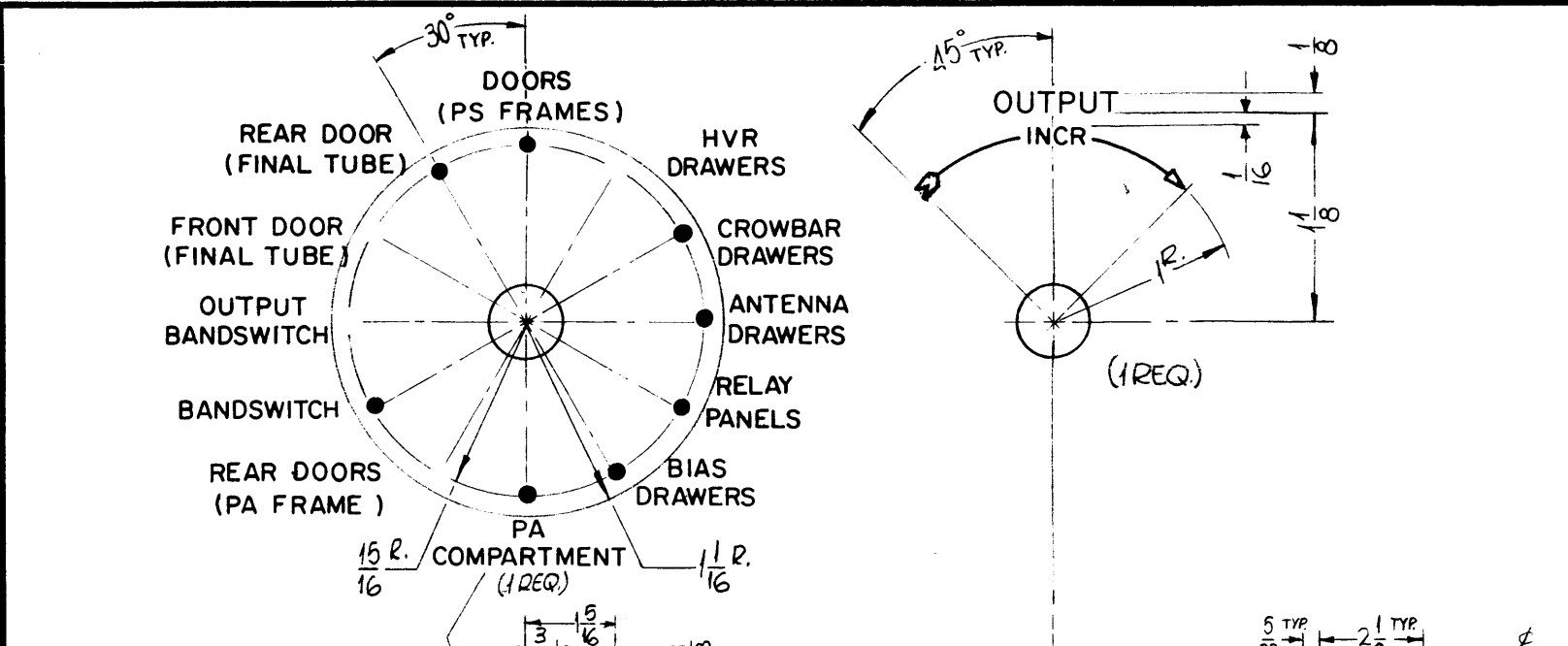

LETTER HEIGHT	DEPTH OF STROKE	WIDTH OF STROKE
3/32	.010	.015
1/8	.010	.020
3/16	.010	.025
DOTS	.010	SEE NOTE 4
ARROWS	.010	.015
SOLID LINES	.010	.015

UNLESS OTHERWISE SPECIFIED

1~ ALL LETTERING 3/32

2~ ALL LETTER GROUPS TO BE CENTERED ON HOLES, CUTOUTS, OR INDICATING LINES AS THE CASE MAY APPLY.

3~ ENGRAVING TO BE GOTHIC, WHITE FILLED, SIZES SHOWN ON CHART.

4~ ALL DOTS TO BE 3/32 DIA. WHITE FILLED

5~ ALL ARROW HEADS 3/32 X 5/32, (DO NOT FILL)

6~ ALL LINES TO BE WHITE FILLED.

NOTES

1	GPT-200K	AX-396
Q'TY./UNIT	MODEL USED ON	ASS'Y. NO.
SCALE	CODE	
DO NOT SCALE (3/8=1")	A	
THE CONTENTS OF THIS DRAWING ARE THE EXCLUSIVE PROPERTY OF THE TECHNICAL MATERIEL CORP. ITS UNAUTHORIZED USE OR REPRODUCTION IN WHOLE OR IN PART IS STRICTLY FORBIDDEN.		

REQ'D.	ITEM	PART NUMBER	DESCRIPTION	SYMBOL
F. BUDETTI				
LIST OF MATERIAL				
MATERIAL			THE TECHNICAL MATERIEL CORP. MAMARONECK, NEW YORK	
FINISH			TITLE MARKING, FRONT PANEL MARKING PROCESS: ENGRAVING	
UNLESS OTHERWISE SPECIFIED DIMENSIONS ARE IN INCHES AND INCLUDE CHEMICALLY APPLIED OR PLATED FINISHES		DRAWN SRG	DATE 1-3-64	FINAL APPROVAL RAC
DECIMALS .X ± .05 .XX ± .01 .XXX ± .005		CHECKED OCB	DATE 2/11/64	DATE
FRACTIONS ± 1/64 ANGLES ± 0° 30'		ELECT. DES. S.B. JB	DATE 2/11/64	DATE
TOLERANCES		MECH. DES. S.D.	DATE 2/11/64	DATE
			LD-1179	0
			SHEET 1 OF 2	REV. LTR.

LD-1179-0

REVISIONS

SYM	DESCRIPTION	DATE	E.M.N. NO.	DRAFT	CHKD	APPD
0	ORIGINAL RELEASE FOR PRODUCTION	3-2-64		A.M.		

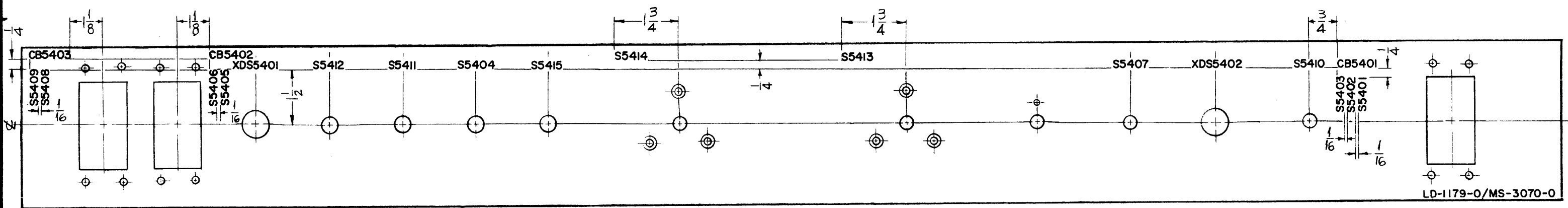

LD-1179-0/MS-3070-0

— REAR VIEW —

MARKING PROCESS: AS PER TMC SPECIFICATION S-727.

LETTERING: 1/8 HIGH BLACK GOTHIC, LOCATED AS SHOWN.

REF: MS-3070

REQ'D.	ITEM	PART NUMBER	DESCRIPTION	SYMBOL
F. BUDETTI LIST OF MATERIAL				
MATERIAL			THE TECHNICAL MATERIEL CORP. MAMARONECK, NEW YORK	
FINISH			TITLE MARKING FRONT PANEL MARKING PROCESS AS PER TMC SPECS. S-727	
UNLESS OTHERWISE SPECIFIED DIMENSIONS ARE IN INCHES AND INCLUDE CHEMICALLY APPLIED OR PLATED FINISHES			DRAWN SRG DATE 1-2-64	FINAL APPROVAL DATE
DECIMALS .X ± .05 .XX ± .01 .XXX ± .005			CHECKED GJB DATE 2/12/64	LD-1179
FRACTIONS ± 1/64 ANGLES ± 0° 30'			ELECT. DES. S.D. DATE 2-12-64	0
TOLERANCES			MECH. DES. S.D. DATE 2-12-64	REV. LTR.
THE CONTENTS OF THIS DRAWING ARE THE EXCLUSIVE PROPERTY OF THE TECHNICAL MATERIEL CORP. ITS UNAUTHORIZED USE OR REPRODUCTION IN WHOLE OR IN PART IS STRICTLY FORBIDDEN.			SHEET 2 OF 2	

1	GPT-200K	AX-396
Q'TY./UNIT	MODEL USED ON	ASS'Y. NO.
SCALE 3/8 = 1"	CODE A	

NOTES