

REVISIONS						
ZONE	LTR	DESCRIPTION	DATE	E.M.N.NO	DRAFT	CHKD APPD
	Ø	ORIGINAL RELEASE FOR PRODUCTION	2-23-73		CL	

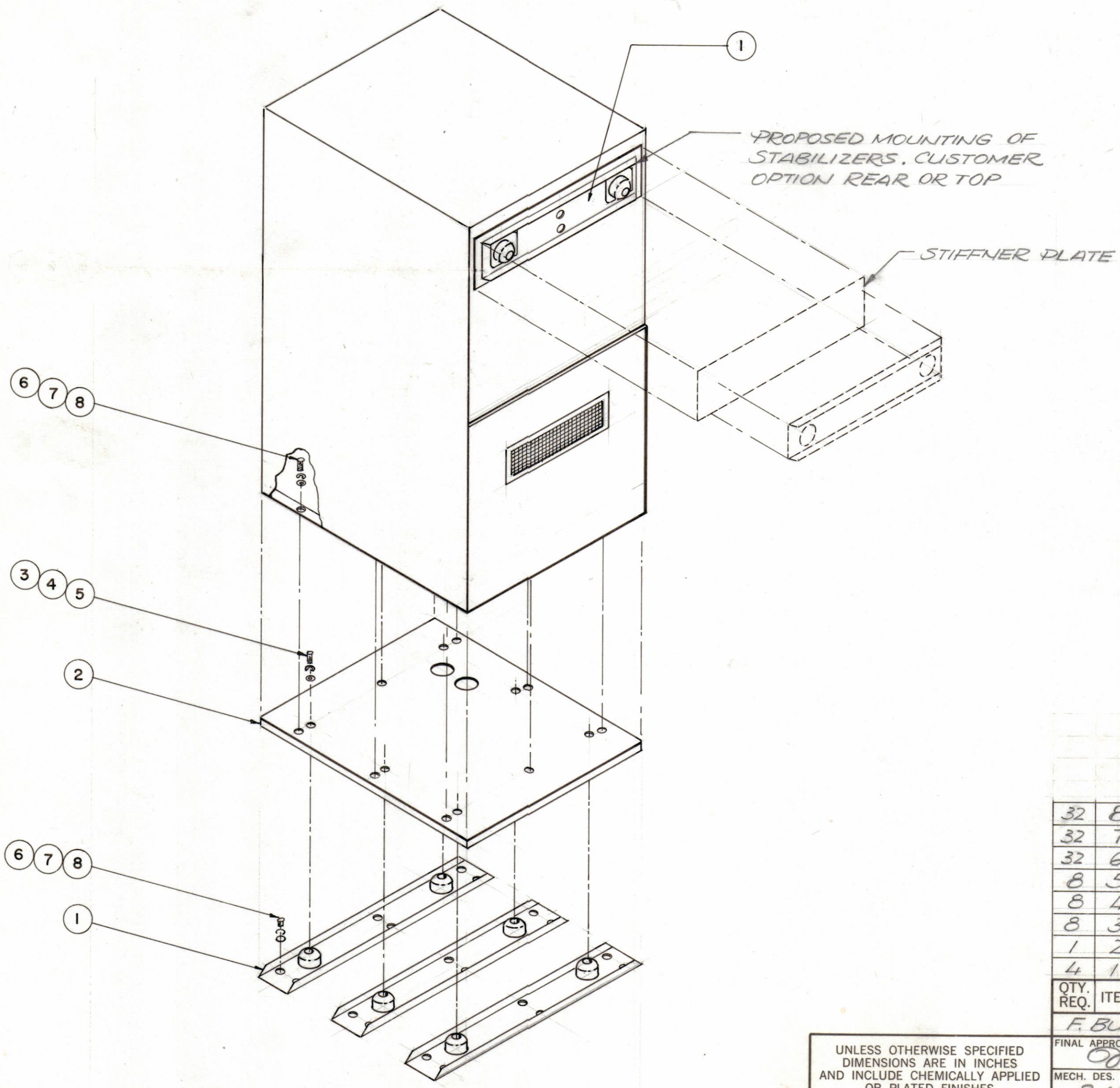

QTY. REQ.	ITEM	PART NO.	DESCRIPTION	SYMBOL
32	8	FW 25 HBN	WASHER, FLAT	
32	7	LWS 25 MRN	WASHER, LOCK	
32	6	SCHH 25205516	SCREW HEX HEAD	
8	5	LWS 37 MRN	WASHER, LOCK SP.	
8	4	FW 37 HBN	WASHER FLAT	
8	3	SCHH 37165516	SCREW HEX HEAD	
1	2	MS 6437	PAD XMTR MTG.	
4	1	MS 5985-3	PAD SHOCK MT. (WITH SHOCKS)	

F. BUDETTI LIST OF MATERIAL				
FINAL APPROVAL	DATE	THE TECHNICAL MATERIEL CORP.		
<i>FB</i>	2-21-73	MAMARONECK, NEW YORK		
MECH. DES. <i>B.N.</i>	DATE 2-21-73	INSTALLATION DIAGRAM		
ELECT. DES.	DATE	HFTA 5KJ SHOCK MTG.		
CHECKED	DATE	SIZE	CODE IDENT. NO.	DWG NO.
DRAWN <i>GE</i>	DATE 2-20-73	C	82679	1D406
MATERIAL		SCALE	SHEET	OF
FINISH				

KIT 391		
QTY / UNIT	MODEL USED ON	ASS'Y NO.
APPLICATION		
CODE		
<p>NOTICE TO PERSONS RECEIVING THIS DRAWING</p> <p>THE TECHNICAL MATERIEL CORPORATION claims proprietary right in the material disclosed herein. This drawing is issued in confidence for engineering information only and may not be reproduced or used to manufacture anything shown hereon without permission from THE TECHNICAL MATERIEL CORPORATION to the user. This drawing is loaned for mutual assistance and is subject to recall at any time.</p>		

UNLESS OTHERWISE SPECIFIED DIMENSIONS ARE IN INCHES AND INCLUDE CHEMICALLY APPLIED OR PLATED FINISHES

TOLERANCES ON

DECIMALS	FRACTIONS
.X ± .05	± 1/64
.XX ± .01	ANGLES
.XXX ± .005	± 0° -30'