

NOTE:
DIMENSIONS INDICATED ARE OF
COIL MOUNTED IN ITS PROPER
LOCATION ON APPROPRIATE
ASS'Y (AS126)

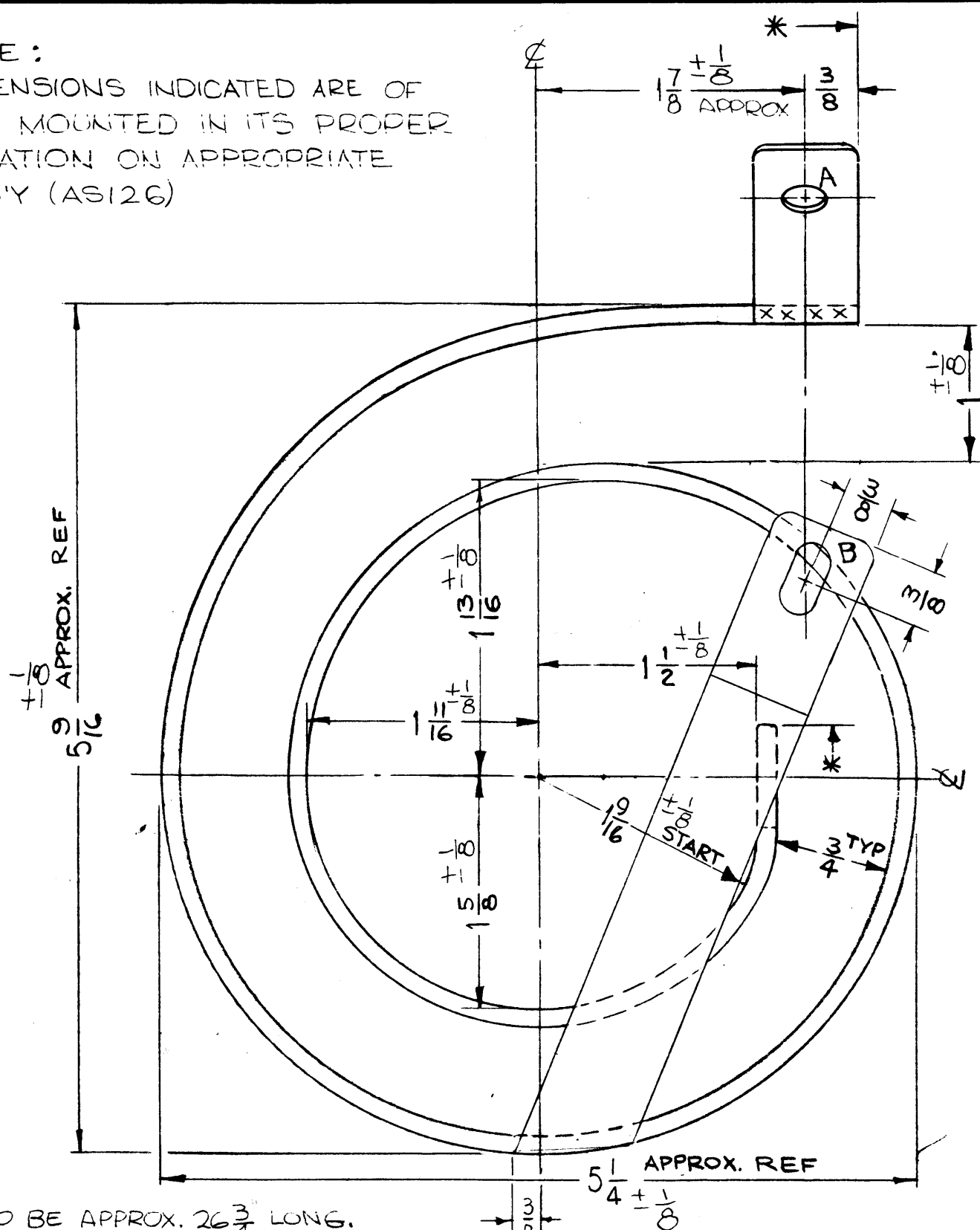

1- * TO BE APPROX. 26 $\frac{3}{4}$ LONG.
2-X SILVER SOLDER TOGETHER AS SHOWN,

CL 354

REVISIONS						
SYM	DESCRIPTION	DATE	E.M.N. NO.	DRAFT	CHKD	APPD
A	TOL ADDED TO DIM, P/N ADDED	6.6.66	16341	utw	OCB	OCB

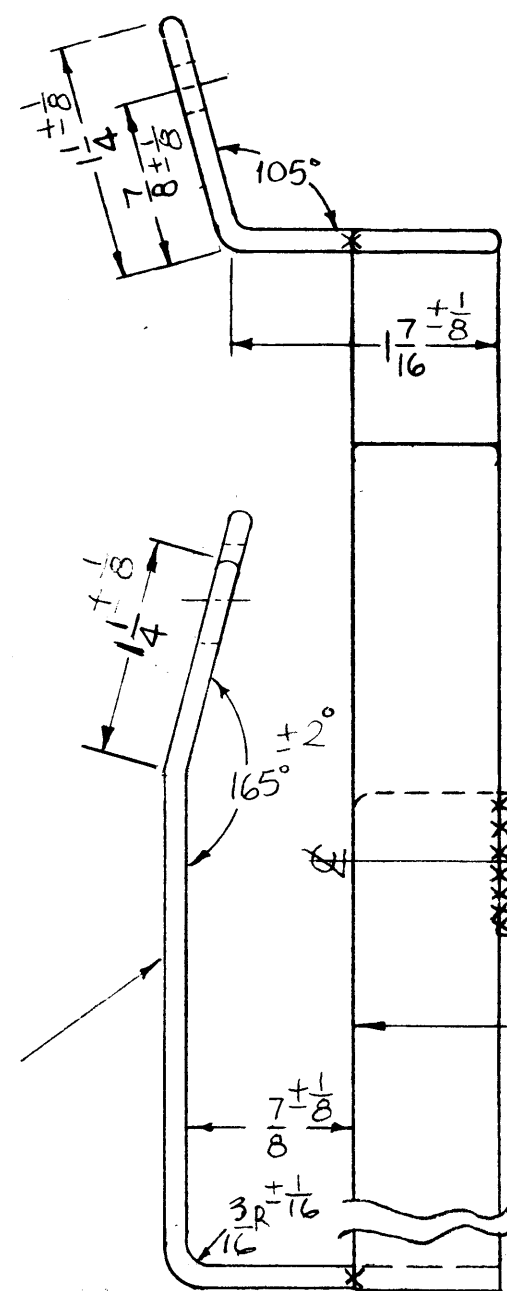

HOLES:
A ~ 9/32 DIA. (4 REQ.)
B ~ 1/4 x 1/2 SLOT (1 REQ.)

MARK TMC PART NO. 1/8
HIGH BLACK GOTHIC W/
LATEST REVISION LETTER
APPROX. AS SHOWN.

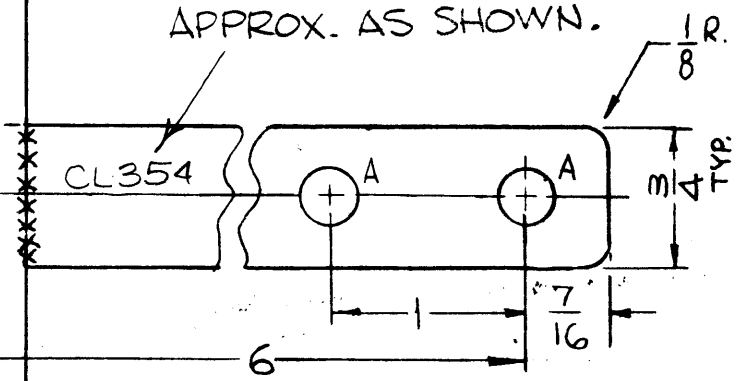

REQ'D.	ITEM	PART NUMBER	DESCRIPTION	SYMBOL
X	1	BS101	BRAZING ALLOY, SILVER	
F. BUDETTI LIST OF MATERIAL				
MATERIAL			THE TECHNICAL MATERIEL CORP.	
1/8 THICK COPPER			MAMARONECK, NEW YORK	
COLD ROLLED			TITLE	
S 245 SILVER PLATE			COIL, RF	
S 423 SILVER-KOTE			DRAWN SRG DATE 3-15-65	
FINISH			CHECKED OCB DATE	
UNLESS OTHERWISE SPECIFIED			ELECT. DES. DATE	
DIMENSIONS ARE IN INCHES AND INCLUDE			MECH. DES. DATE 5/18/66	
CHEMICALLY APPLIED OR PLATED FINISHES			FINAL APPROVAL OCB DATE 5/19/66	
DECIMALS			SHEET	
.X ± .05			REV. LTR. A	
.XX ± .01				
.XXX ± .005				
TOLERANCES				
FRACTIONS				
± 1/64				
ANGLES				
± 0° 30'				

1	TST (110K	ASS'Y. NO.
Q'TY./UNIT	MODEL USED ON	ASS'Y. NO.
SCALE	CODE	
DO NOT SCALE	A	
THE CONTENTS OF THIS DRAWING ARE THE EXCLUSIVE PROPERTY OF THE TECHNICAL MATERIEL CORP. ITS UNAUTHORIZED USE OR REPRODUCTION IN WHOLE OR IN PART IS STRICTLY FORBIDDEN.		

NOTES