

CL-223 B

OPER. FREQ.	REQ. PER UNIT	M DEL	ASSY. NO.	DATE
19-24 Mc	1	GPT-40K	AX-209	4-6-60
19-24 Mc	1	GPT-40K () 3 AS-120	AX-294	12-23-63
24-28 Mc	1	GPT-40K () 4 AS-125	AX-459	12-23-63

INDUCTANCE - .15 μhy
 OPER FREQ - SEE CHART

MATERIAL - 3/8 OD COPPER
 FINISH - SILVER PLATE

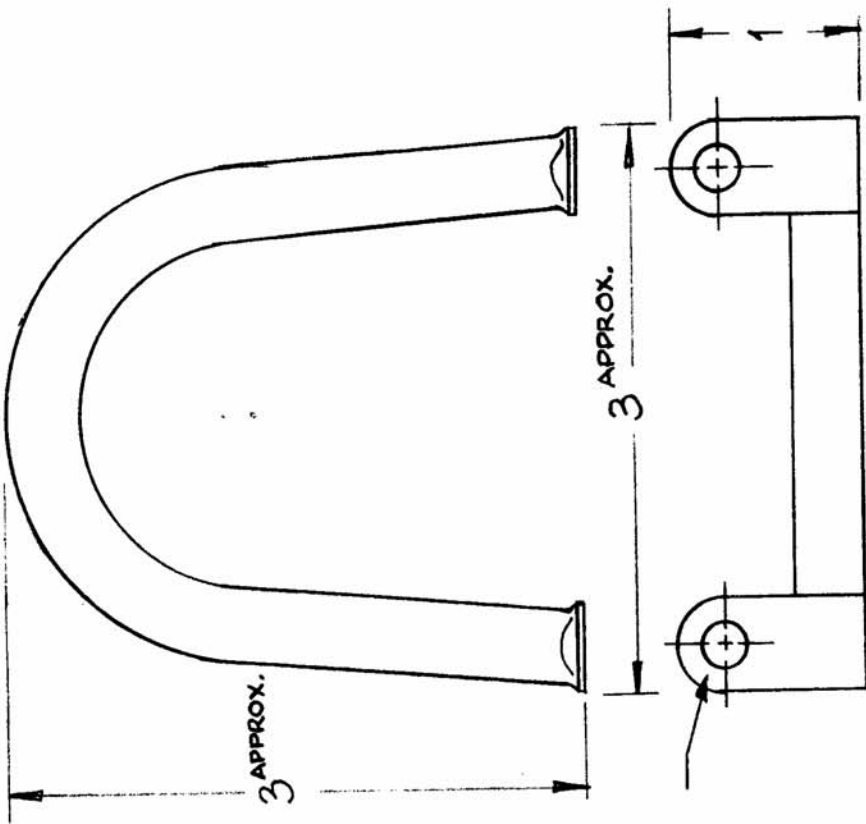

15/64 D. ~ 2 Req'd

REQ. ITEM	PART NO.	DESCRIPTION	SYMB L
		THE TECHNICAL MATERIEL CORP. MAMARONECK, NEW YORK	
		COIL, RF.	
		"L" SECTION	
		CHECKED	
		DRAWN	
		HEAT TREAT. SPEC.	
		TYPE & TEMPER	
		FINISH & SPEC. NO.	
		ELEC. DES. APP	
		MECH. DES. APP	
		CL-223	B

15/63 10642
 1-23-63 8064
 DATE CH. NO. DRAFTS CHECKER ENG. APP.
 SCALE: 1FP175
 MAXIMUM ALLOWABLE TOLERANCES HAVE BEEN DETERMINED AND ANY DEVIATIONS WILL BE CAUSE FOR REJECTION. REMOVE ALL BURRS AND SHARP EDGES

DEC. DIM. ±
 FRAC. DIM. ±
 ANGULAR DIM. ±