

REVISIONS						
ZONE	LTR	DESCRIPTION	DATE	E.M.N.NO	DRAFT	CHKD
X		REDRAW #OF12D7231			GAOB	
X		ADDED CHANGES SUPP BY G.FLETCHER	6-10-68		CAROB	
Ø		CHANGES SUPPLIED BY M&P ELECTRONICS	6-21-68		C. GARDNER	JFP
A		ADDED DESIGNATION TO TB1, J1, J2, J3, J4	1-23-69		NT	

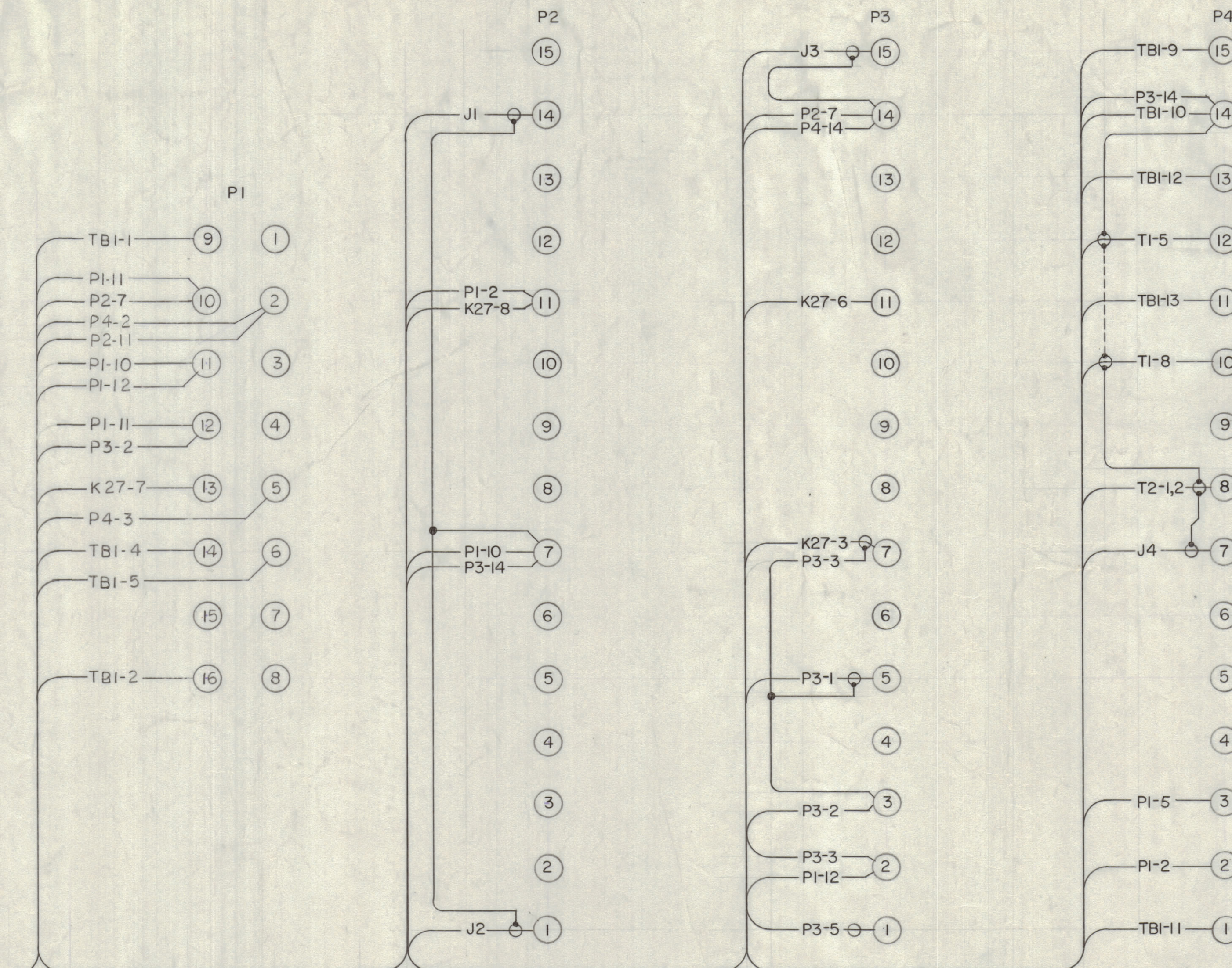

NOTE:
THIS DIAGRAM REPRESENTS HALF, OR ONE CHANNEL, OF
THE COMPLETE WIRING
TWO CHANNELS PER AX 8029 ASSY

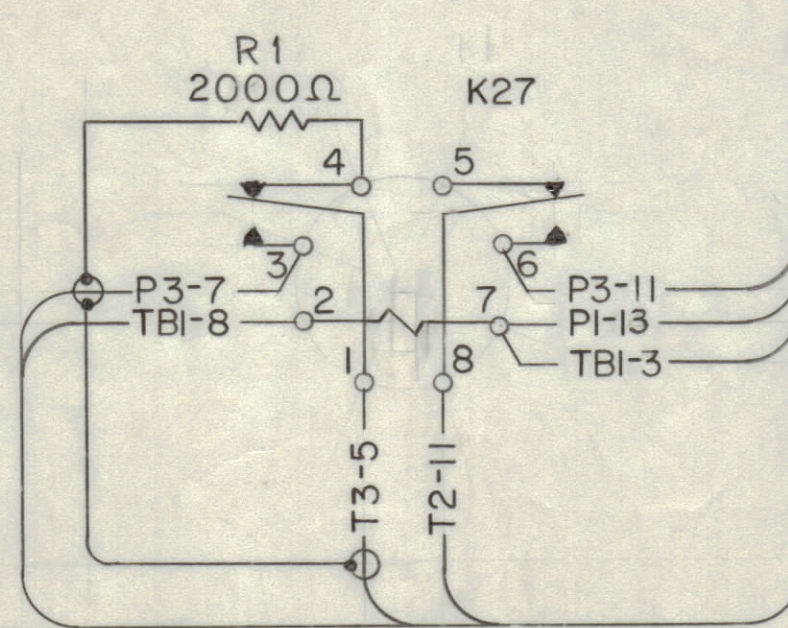
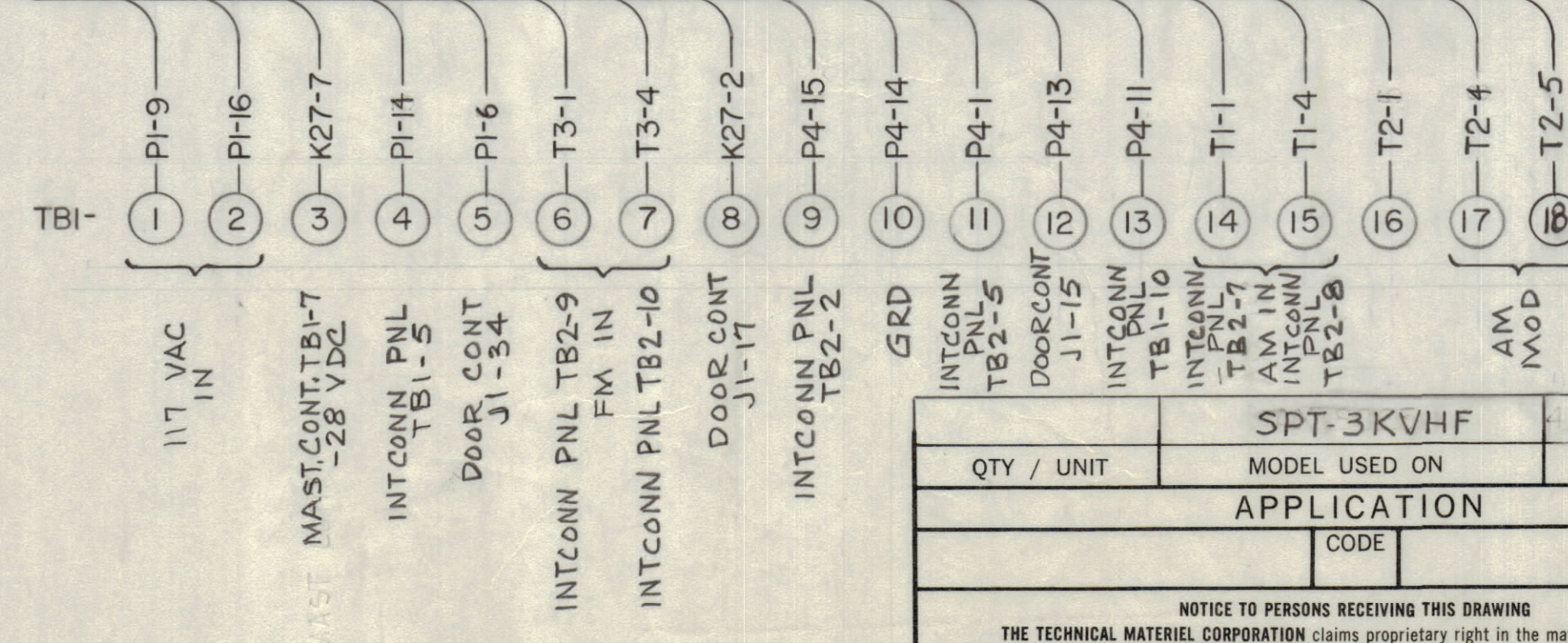
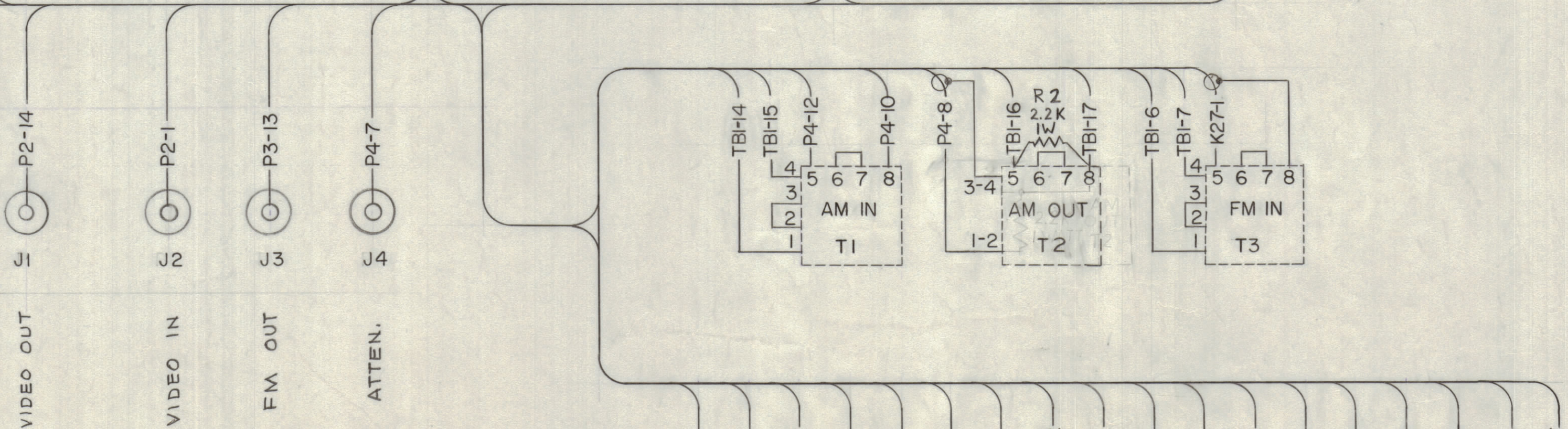

WIRING ONLY
CK 8147

QTY. REQ.	ITEM	PART NO.	DESCRIPTION	SYMBOL
LIST OF MATERIAL				
FINAL APPROVAL		DATE	THE TECHNICAL MATERIEL CORP. MAMARONECK, NEW YORK WIRING DIAGRAM SIGNAL PROCESSOR ACCESSORY CABINET AX 8029	
MECH. DES.		DATE		
ELECT. DES.		DATE		
CHECKED		DATE		
DRAWN		DATE	SIZE CODE IDENT. NO. DWG. NO. ISSUE D 82679 CK8102 A	
MATERIAL			SCALE	
FINISH			SHEET 1 OF 1	

QTY / UNIT	MODEL USED ON	ASS'Y NO.
	SPT-3KVHF	AX 8029
APPLICATION		
CODE		

NOTICE TO PERSONS RECEIVING THIS DRAWING
THE TECHNICAL MATERIEL CORPORATION claims proprietary right in the material disclosed herein. This drawing is issued in confidence for engineering information only and may not be reproduced or used to manufacture anything shown herein without permission from THE TECHNICAL MATERIEL CORPORATION to the user. This drawing is loaned for mutual assistance and is subject to recall at any time.

CK8102