

4

3

2

1

	LENGTH	FROM	TO
CA13-1	AG500-1 P	AG500-1 P	TB133-1
CA13-2		AG500-2	TB133-2
CA13-3		AG500-3	TB133-3
CA13-4		AG500-4	TB133-4

REVISIONS						
ZONE	LTR	DESCRIPTION	DATE	E.M.N.NO	DRAFT	CHKD APPD
	Ø	ORIGINAL RELEASE FOR PRODUCTION	8/20/70		RG	

AG500-1

TAPE RECORDER
REMOTE CONTROL

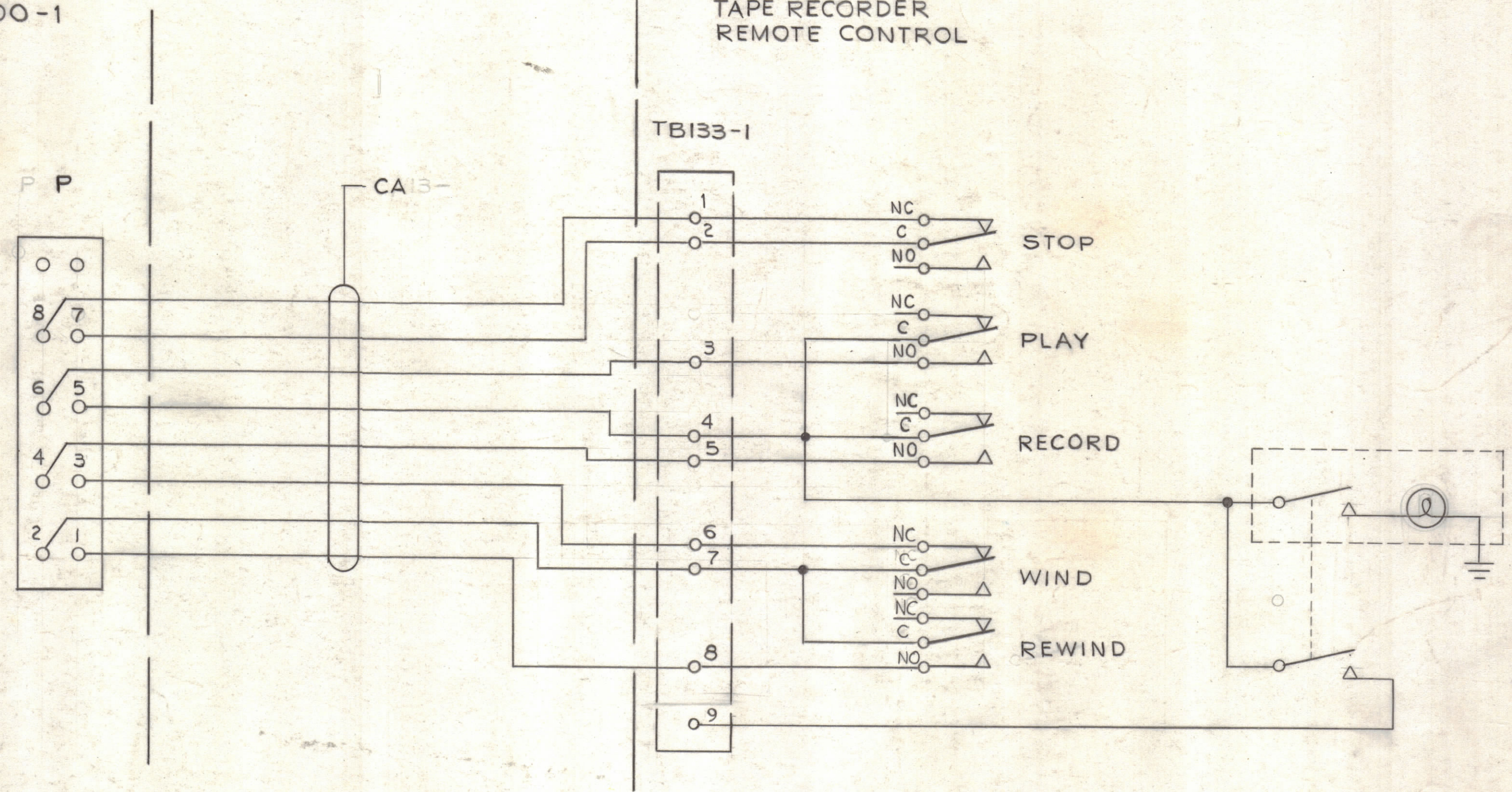

- NOTES:
1. SPADE LUGS ON TB RECORDER END PLUG SUPPLIED.
 2. WIRE, NO. 22 PER T.M.C. SPEC

QTY / UNIT	MODEL USED ON	ASS'Y NO.
APPLICATION		
CODE		

NOTICE TO PERSONS RECEIVING THIS DRAWING
 THE TECHNICAL MATERIEL CORPORATION claims proprietary right in the material disclosed hereon. This drawing is issued in confidence for engineering information only and may not be reproduced or used to manufacture anything shown hereon without permission from THE TECHNICAL MATERIEL CORPORATION to the user. This drawing is loaned for mutual assistance and is subject to recall at any time.

UNLESS OTHERWISE SPECIFIED DIMENSIONS ARE IN INCHES AND INCLUDE CHEMICALLY APPLIED OR PLATED FINISHES

TOLERANCES ON

DECIMALS	FRACTIONS
.X ± .05	± 1/64
.XX ± .01	ANGLES
.XXX ± .005	± 0° -30'

MATERIAL — / —
 FINISH — / —

QTY. REQ.	ITEM	PART NO.	DESCRIPTION	SYMBOL
LIST OF MATERIAL				
THE TECHNICAL MATERIEL CORP. MAMARONECK, NEW YORK				
WIRING DIAGRAM FOR AG500-1 & 2 REMOTES				
FINAL APPROVAL <i>E. J. Landi</i>		DATE 8/19/70		SCALE — / —
MECH. DES.		DATE		
ELECT. DES.		DATE		
CHECKED		DATE		
DRAWN <i>Amiska</i>		DATE 10-6-67		SHEET 1 OF 1
SIZE	CODE IDENT. NO.	DWG NO.	ISSUE	
C	82679	CK8006	Ø	

4

3

2

1