

REVISIONS							
E.M.N.O.	DRAFT	CHKD	ZONE	LTR	DESCRIPTION	DATE	APPROVED
	①				ORIGINAL RELEASE FOR PRODUCTION	1/15/71	PEB
20441	R#	②		A	CHG. BREAKOUT 5, IT. 8#11 & M/L, IT. 8#11	8-16-71	PEB

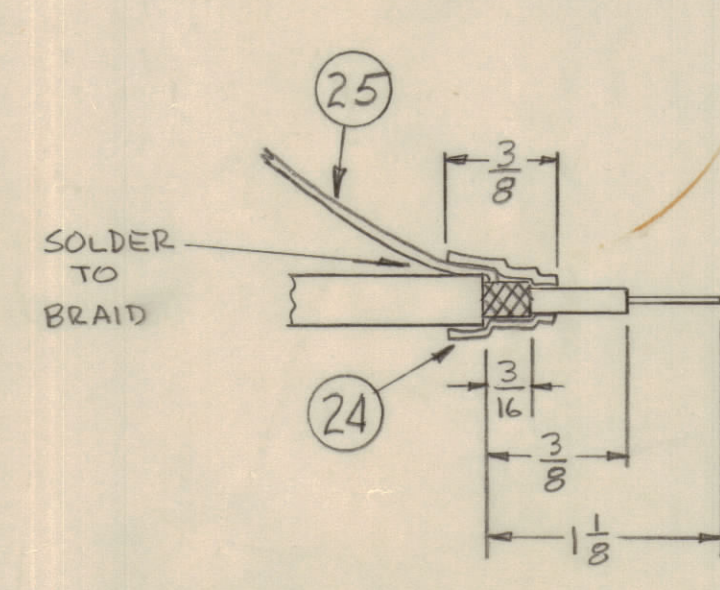
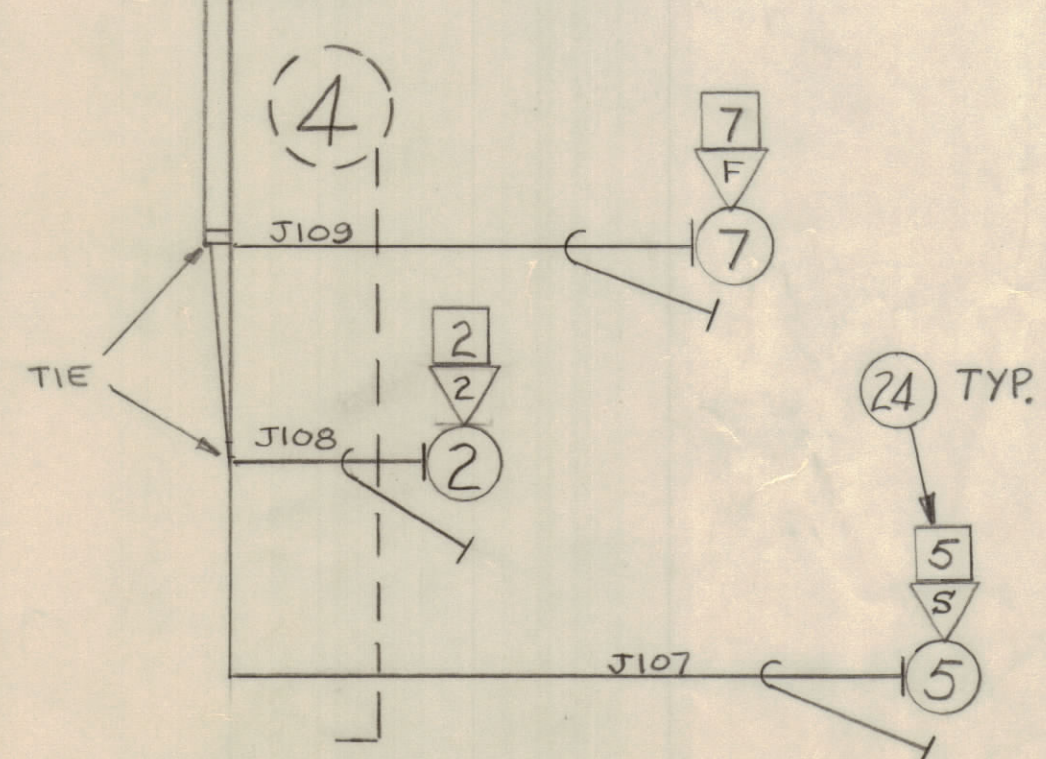
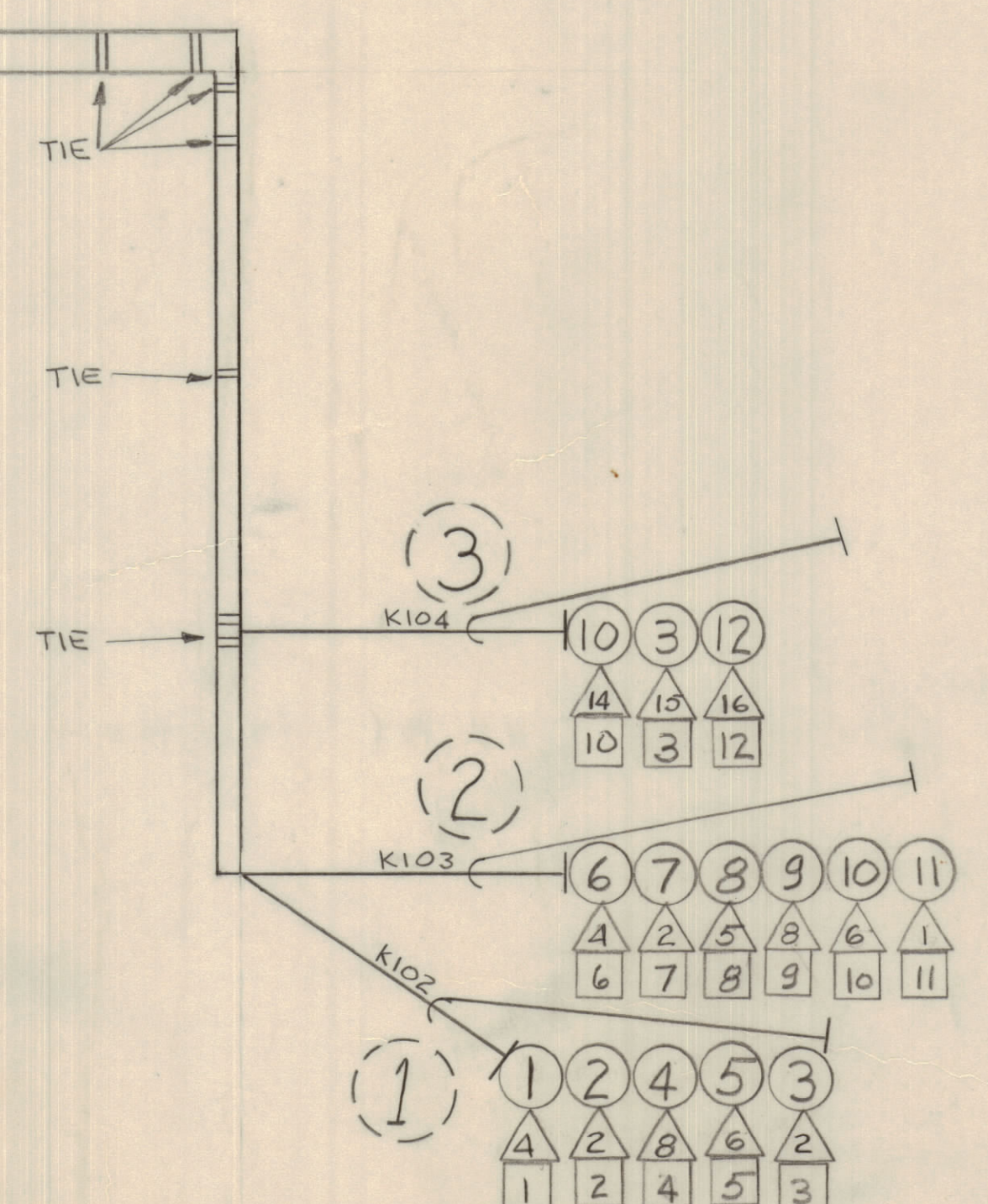
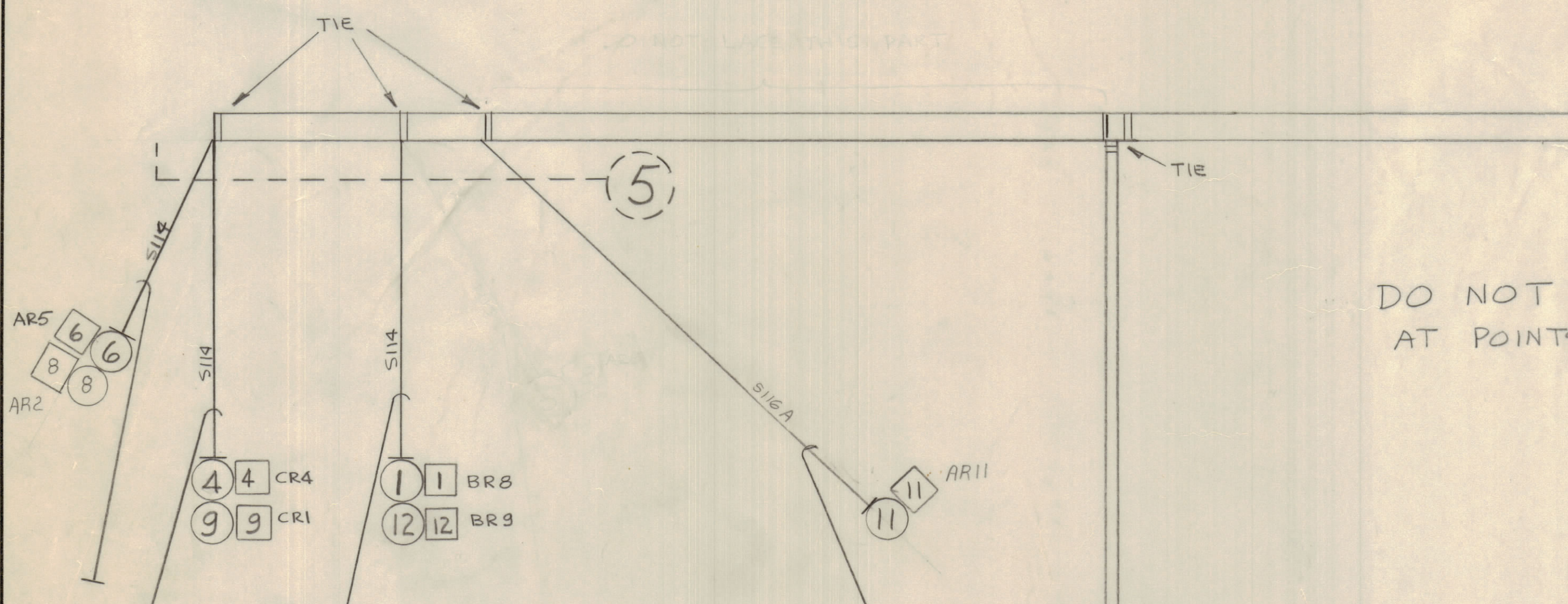

THIS SYMBOL DENOTES END OF INSULATION & NAIL DRIVING POINT
WIRE MUST BE STRIPPED 3/4" BEYOND THIS POINT & TINNED 1/2".
EXTEND PIGTAIL TO THIS POINT. PIGTAIL TO BE STRIPPED 3/4" BEYOND
THIS POINT & TINNED 1/2".

FROM	TO	QTY	ITEM	PART NUMBER	DESCRIPTION	SYM	FROM	TO	QTY. REQ.	ITEM	PART NO.	DESCRIPTION	SYMBOL
									20				
									19				
									18				
									17				
									16				
									15				
									14				
									13				
									12	R6174/U	K104 PIN 16	S114 B REAR-9	
									11		K103 PIN 1	S116 A REAR-11	
									10		K103 PIN 6	K104 PIN 4	
									9		K103 PIN 8	S114 C REAR-1	
									8		K103 PIN 5	S114 A REAR-2	
									7		K103 PIN 2	J109 PIN F	
									6		K103 PIN 4	S114 A REAR-5	
									5		K102 PIN 6	J107 PIN 5	
									4		K102 PIN 8	S114 C REAR-4	
									3		K102 PIN 2	K104 PIN 15	
									2		K102 PIN 2	J108 PIN 2	
									1	R6174/U	K102 PIN 4	S114 B REAR-8	

1	MMXA-2A	KIT 368
QTY / UNIT	MODEL USED ON	ASSY NO.
APPLICATION		
CODE		
MATERIAL		
FINISH		

UNLESS OTHERWISE SPECIFIED DIMENSIONS ARE IN INCHES AND INCLUDE CHEMICALLY APPLIED OR PLATED FINISHES	FINAL APPROVAL	DATE
TOLERANCES ON	MECH. DES.	DATE
DECIMALS	ELECT. DES.	DATE
FRACTIONS	CHECKED	DATE
ANGLES	DRAWN	DATE
PLATED FINISHES		

LIST OF MATERIAL			
THE TECHNICAL MATERIEL CORP. MAMARONECK, NEW YORK			
WIRING HARNESS RF			
SIZE	CODE IDENT NO.	DWG NO.	ISSUE
D	82679	CA1633	A
SCALE			SHEET OF

NOTICE TO PERSONS RECEIVING THIS DRAWING
THE TECHNICAL MATERIEL CORPORATION claims proprietary right in the material disclosed hereon. This drawing is issued in confidence for engineering information only and may not be reproduced or used to manufacture anything shown hereon without permission from THE TECHNICAL MATERIEL CORPORATION to the user. This drawing is loaned for mutual assistance and is subject to recall at any time.