

REQ. PER. UNIT 2	MODEL CU-2	USED ON ASSY. NO. A-1795	DATE 11-2-59	BX-187	A
---------------------	---------------	-----------------------------	-----------------	--------	---

HOLES
 A ~ 3/32 (.093) Dia. REQ'D. 1
 B ~ 1/8 (.125) " 3
 C ~ 17/64 (.266) " 2

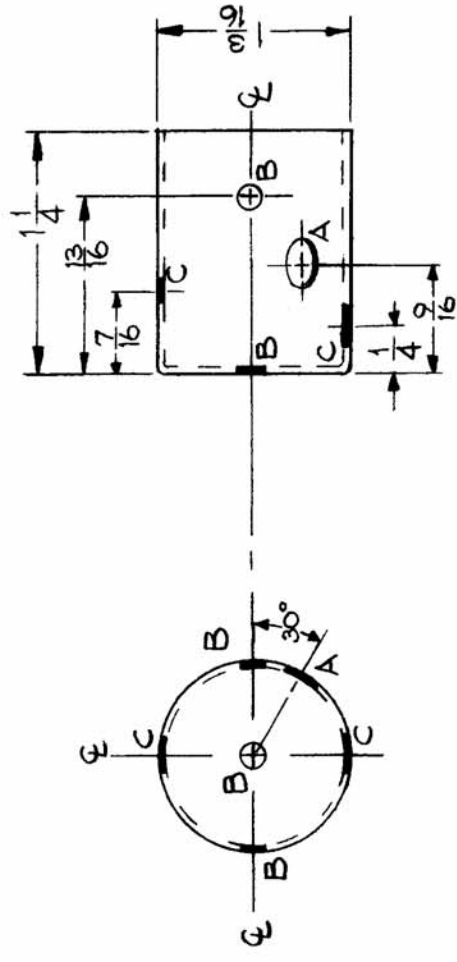

REF- HUDSON TOOL & DIE CO.

REQ. ITEM	PART NO.	DESCRIPTION	SYMBOL
		.019 THICK STOCK SIZE	
		BRASS	
MATERIAL			
NONE			
TYPE & TEMPER		HEAT TREAT. SPEC.	
NONE		NONE	
FINISH & SPEC. NO.		P.L.S.G. DES. APP. MECH. DES. APP.	
TOLERANCES		SCALE: PD NOT SCALE	
DEC. DIM. ±	CHANGED FROM	MAXIMUM ALLOWABLE TOLERANCES HAVE BEEN DETERMINED AND ANY DEVIATIONS WILL BE CAUSE FOR REJECTION. REMOVE ALL BURRS AND SHARP EDGES	
FRAC. DIM. ± 1/64	DATE 5/29/61	CH. NO. 4958	DRAFTS 100%
ANGULAR DIM. ±	CHECKER	ENG. APP.	100%
	DRAWN	CHECKED	FINAL APPROVAL
	D. MANCUSO	A. S. G.	DRP
			BX-187
			A