

BX 162

NOTE - PAINT ONLY TOP OF COVER  
DO NOT PAINT SIDES

A - .089 HOLES - 7 REQ.  
B - 11/64 (17) D - 2 REQ.

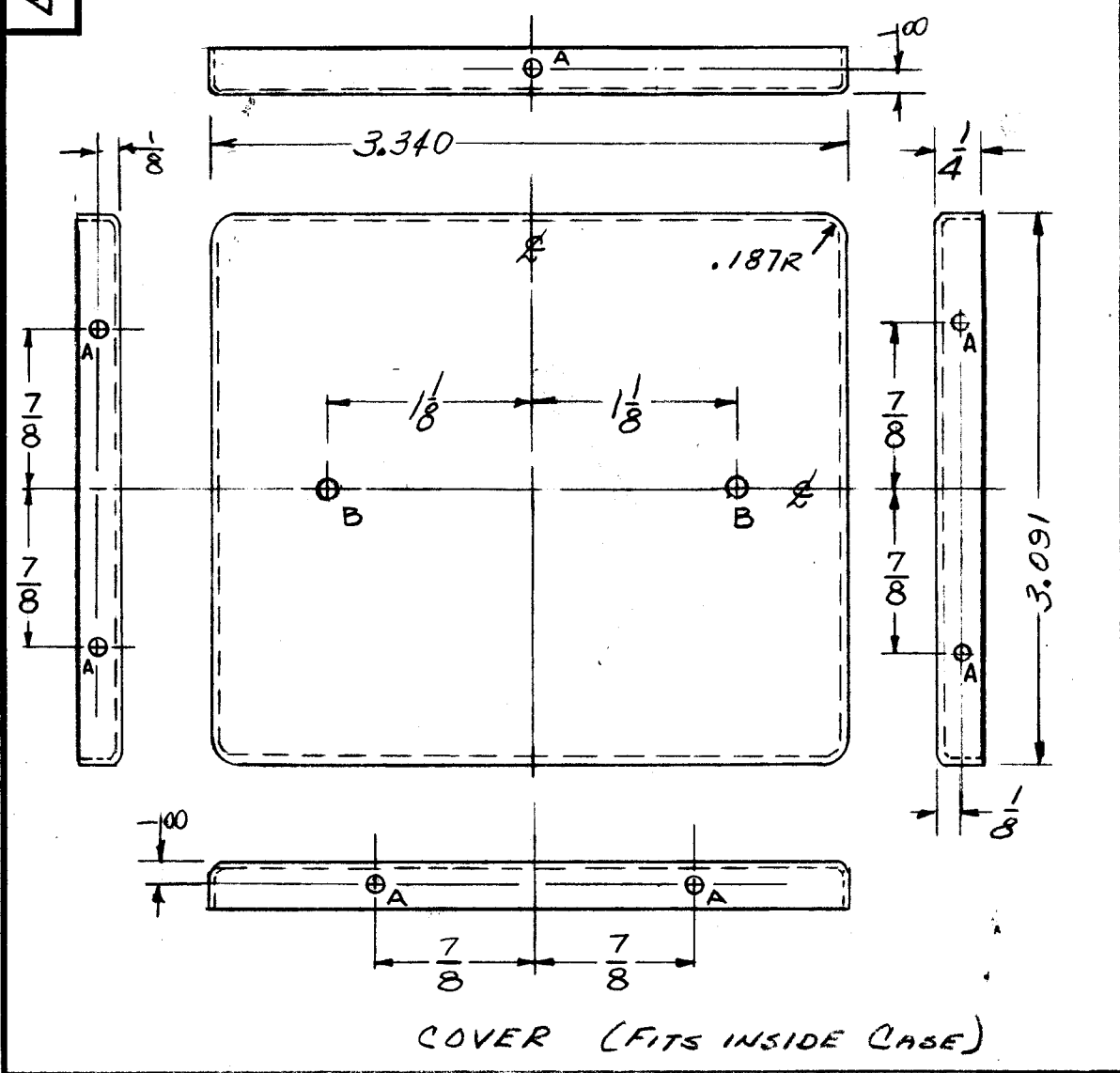

COVER (FITS INSIDE CASE)

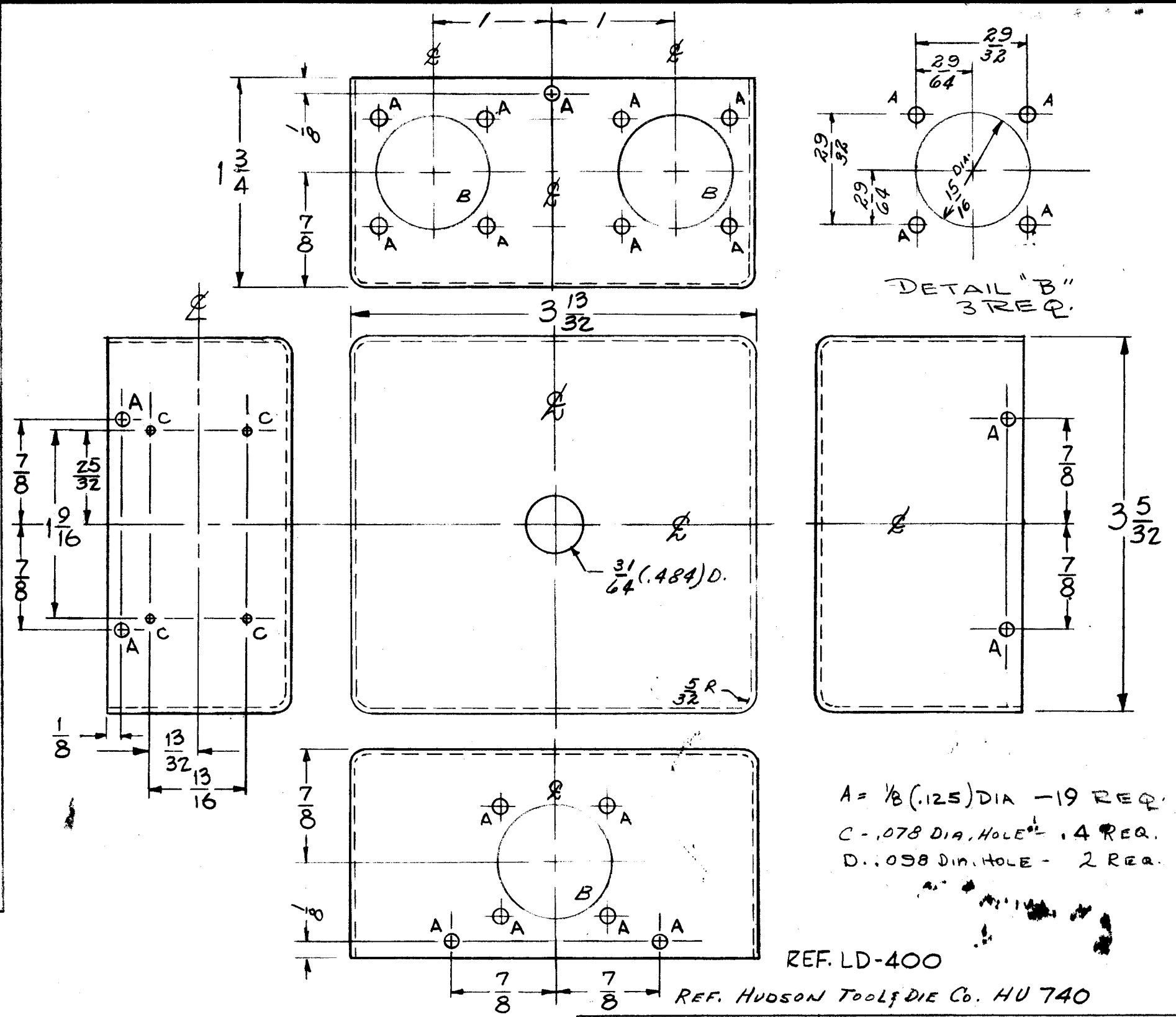

DETAIL "B"  
3 REQ.

A = 1/8 (.125) DIA - 19 REQ.  
C = .078 DIA, HOLE - 4 REQ.  
D = .098 DIA, HOLE - 2 REQ.

REF. LD-400

REF. HUDSON TOOL & DIE Co. HU 740

ISSUE	ITEM	CHANGED FROM	DATE	CH. NO.	DRAFTS	CHECKER	ENG. APP.
D	1	ON COVER - MAT'L NOTE DELE.	7.13.64	11699	WJB	[Signature]	[Signature]
C	1	completely Revised	5/12/59	968	JCB	[Signature]	[Signature]
B	1	TO COVER DELETED N.A. HOLES ADDED 1/8 HOLES FOR 8 HOLES BOX ADDED FOR 2 HOLES	10/20/58	430	WJB	[Signature]	[Signature]
A	2	Cover Ref. was HU-712C; Box Ref. was HU 1014. DIMS CHGD TO AGREE.	5/10/58		WJB	[Signature]	[Signature]

TOLERANCES		SCALE:
DEC. DIM. ±	.005	MAXIMUM ALLOWABLE TOLERANCES HAVE BEEN DETERMINED AND ANY DEVIATIONS WILL BE CAUSE FOR REJECTION. REMOVE ALL BURRS AND SHARP EDGES
FRAC. DIM. ±	1/64	
ANGULAR DIM. ±		

REQ. PER UNIT	MODEL	PROJECT NO.	ASSY. NO.	DATE
1	JB-1	SWR-3000	A-1550	6-10-58

REQ. ITEM	PART NO.	DESCRIPTION	SYMBOL
	.025 THICK STOCK SIZE	THE TECHNICAL MATERIEL CORP. MAMARONECK, NEW YORK	
	BRASS	CASE & COVER	
		SWR-3000-JB1	
		5/22/58 arc	[Signature]
		DRAWN	[Signature]
		CHECKED	[Signature]
		FINAL APPROVAL	[Signature]
		ELEC. DES. APP.	
		MECH. DES. APP.	

BX-162 D