

IF IT IS FOUND DESIRABLE TO CHANGE ANY TOLERANCE OR OTHER DETAIL SPECIFIED ON THIS DRAWING NOTIFY THE PURCHASER PROMPTLY.

MAXIMUM ALLOWABLE TOLERANCES HAVE BEEN DETERMINED AND DEVIATIONS WILL BE CAUSE FOR REJECTION. REMOVE ALL BURRS AND SHARP EDGES

BX-129 C

A - 11/64 (.171) D 2 HOLES REQ.
 B - 41/64 (.640) D 3 HOLES REQ.

NOTICE TO PERSONS RECEIVING THIS DRAWING
 THE TECHNICAL MATERIEL CORPORATION claims proprietary right in the material disclosed hereon. This drawing is issued in confidence for engineering information only and may not be reproduced or used to manufacture anything shown hereon without permission from THE TECHNICAL MATERIEL CORPORATION to the user. This drawing is loaned for mutual assistance and is subject to recall at any time.

Property of:
 THE TECHNICAL MATERIEL CORPORATION
 MAMARONECK, NEW YORK

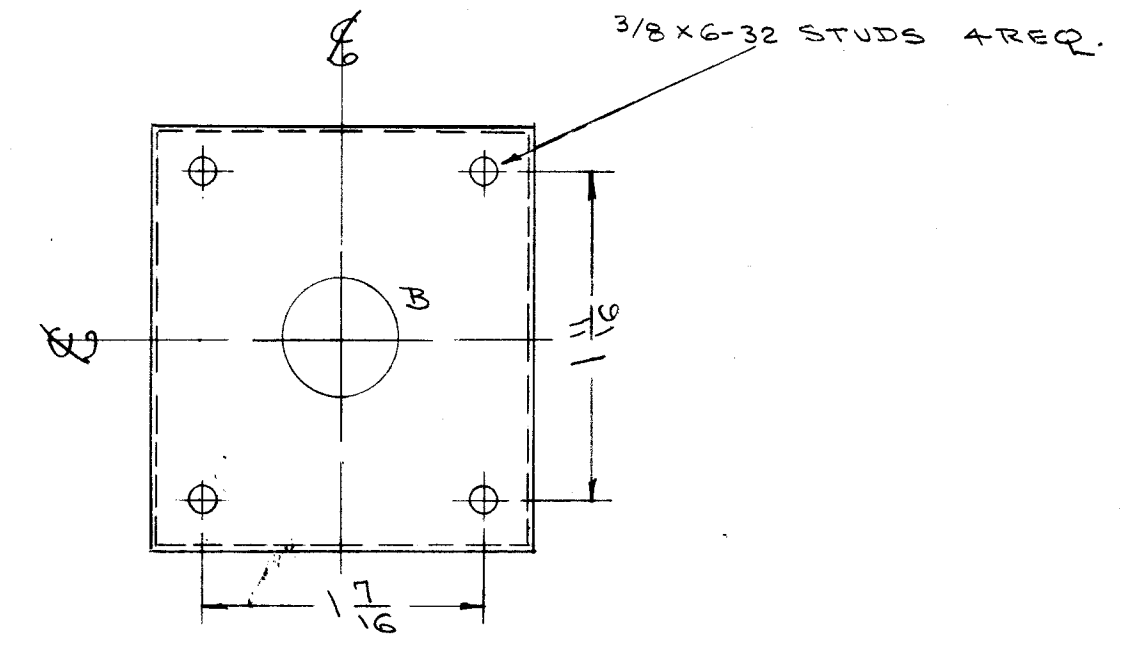
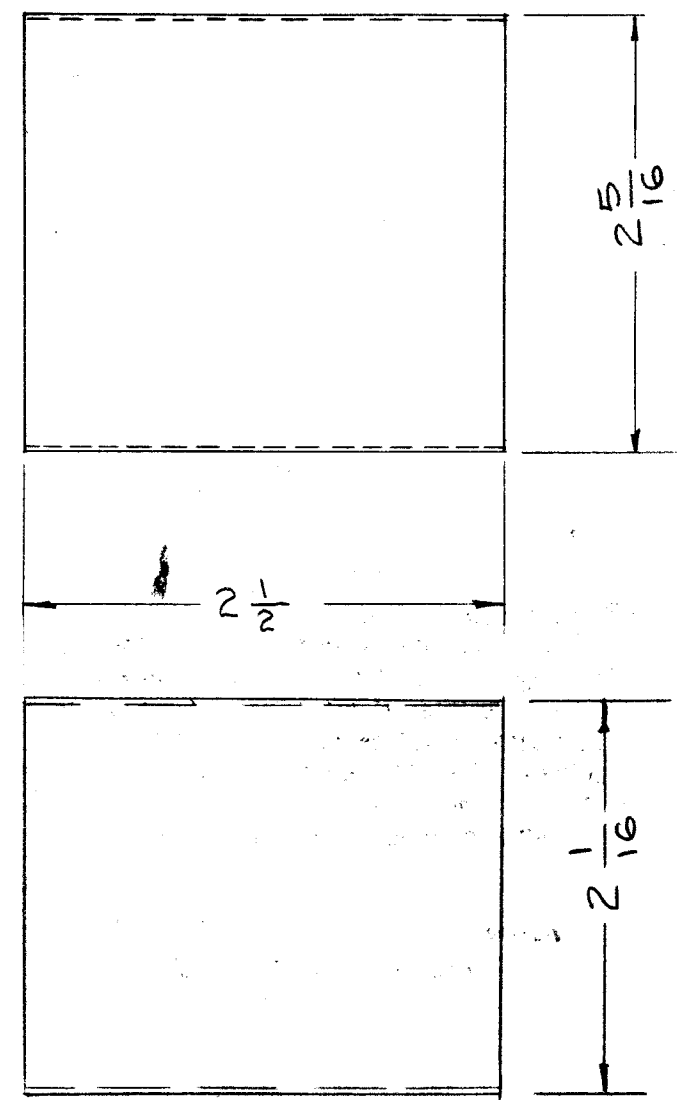
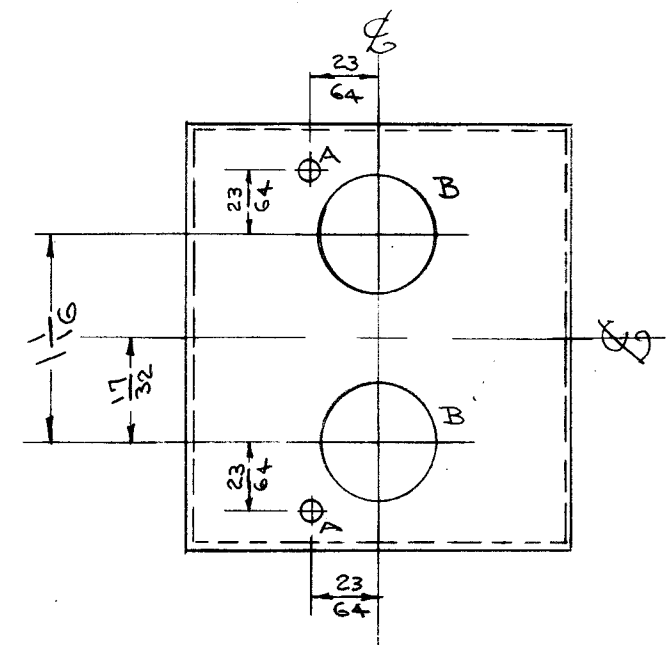

REF: TMC-BX-100-83 (HELDOR-108FB)

C	1	O/A DIM. CHGD FROM 2 1/4 TO 2-5/16 X 2-1/16 ACC TO MIL-T-27A	1/4/58	3	16	JAR	WJ
B	1	FINISH WAS ELECTRO TIN	8/3/55	2	ESD	JAR	WJ
A	1	B - WAS 43/64 (ERROR)	3/15/54	1	P.B.	ESD	WJ
ISSUE	ITEM	CHANGED FROM	DATE	CN. NO.	DRAFTS	CHECKER	ENG. APP.

TOLERANCES		SCALE:	
ALL OTHERS	DEC. DIM. ± FRAC. DIM. ± 1/64 ANGULAR DIM. ±	DRILL, PUNCH, COMMERCIAL STOCK SIZES AND MANUFACTURERS TOLERANCES ARE NOT INCLUDED.	1

REQ. PER UNIT	TR-107	PROJECT NO.	A-937	DATE	2-18-55
USED ON					

REQ. ITEM	PART NO.	DESCRIPTION	SYMBOL
	BX-100-83	THE TECHNICAL MATERIEL CORP., MAMARONECK, NEW YORK	
	STOCK SIZE		
	STEEL	CASE, TRANSFORMER	
	MATERIAL	TR-107	
	WEIGHT PER PC.		
	TYPE & TEMPER	JAR 2-17-55 DRAWN	WJ MECH. DES. APP.
	HEAT TREAT. SPEC.	P.B. ELEC. DES. APP.	WJ MECH. DES. APP.
	FINISH & SPEC. NO.	CHECKED	FINAL APPROVAL
			BX-129 C