

IF IT IS FOUND DESIRABLE TO CHANGE ANY TOLERANCE OR OTHER DETAIL SPECIFIED ON THIS DRAWING NOTIFY THE PURCHASER PROMPTLY.

MAXIMUM ALLOWABLE TOLERANCES HAVE BEEN DETERMINED AND DEVIATIONS WILL BE CAUSE FOR REJECTION. REMOVE ALL BURRS AND SHARP EDGES

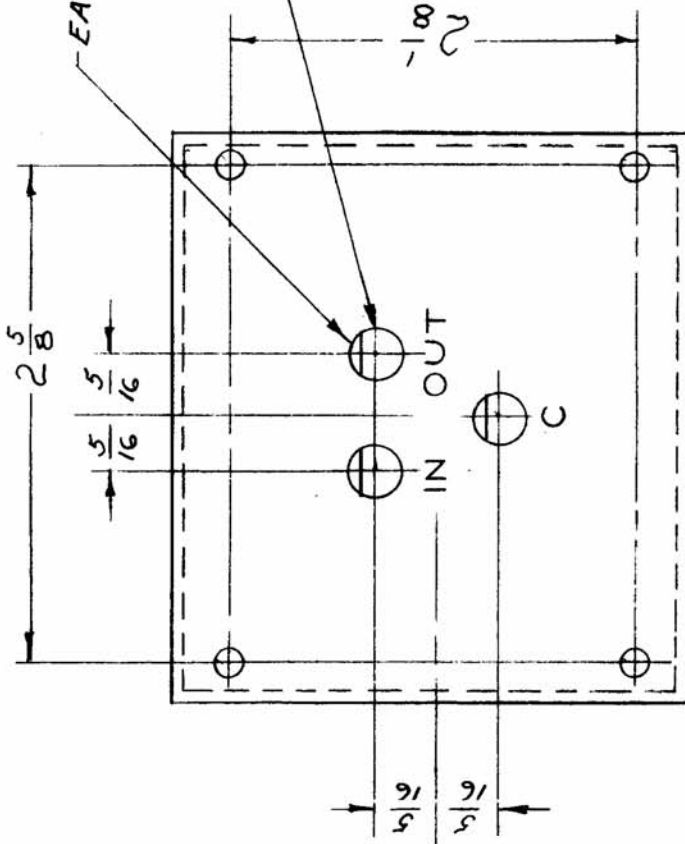

METAL STAMP IN, OUT & C AS SHOWN. 1/8 HIGH

BX-121

USED ON

PROJECT NO.

MODEL

FX-147

REQ. PER UNIT

1

ASSY. NO.

A-888

DATE

11/8/54

3	2	TE-134	LUG TERMINAL	
1	1	BX-100-14 D	CASE TRANSFORMER	
REQ. ITEM	PART NO.		DESCRIPTION	SYMBOL
			THE TECHNICAL MATERIEL CORP.	
	STOCK SIZE		MAMARONECK, NEW YORK	
	MATERIAL		TERMINAL ASSEMBLY	
	WEIGHT PER PC.		(DRILLING PLAN)	
	TYPE & TEMPER			M.H.S.
	HEAT TREAT. SPEC.			
	FINISH & SPEC. NO.			
DRAWN		ELEC. DES. APP.		MECH. DES. APP.
P.B. 11-154		A.T.J.		W.C.
CHECKED		FINAL APPROVAL		
Supercedes		A-471		BX-121

ISSUE ITEM	CHANGED FROM	DATE	CN. NO.	DRAFTS	CHECKER	ENG. APP.
TOLERANCES						
SCALE						
DRILL, PUNCH, COMMERCIAL STOCK SIZES AND MANUFACTURERS TOLERANCES ARE NOT INCLUDED.						
ALL DEC. DIM. ±						
OTHERS FRAC. DIM. ±						
ANGULAR DIM. ±						