

IF IT IS FOUND DESIRABLE TO CHANGE ANY TOLERANCE OR OTHER DETAIL SPECIFIED ON THIS DRAWING NOTIFY THE PURCHASER PROMPTLY.

MAXIMUM ALLOWABLE TOLERANCES HAVE BEEN DETERMINED AND DEVIATIONS WILL BE CAUSE FOR REJECTION. REMOVE ALL BURRS AND SHARP EDGES

BX-114 F

TE-101-1 COMPLETE WITH SOLDER LUG & NUT. 6 REQ.

6-32 STUDS - DOUBLE END - 4 REQ.

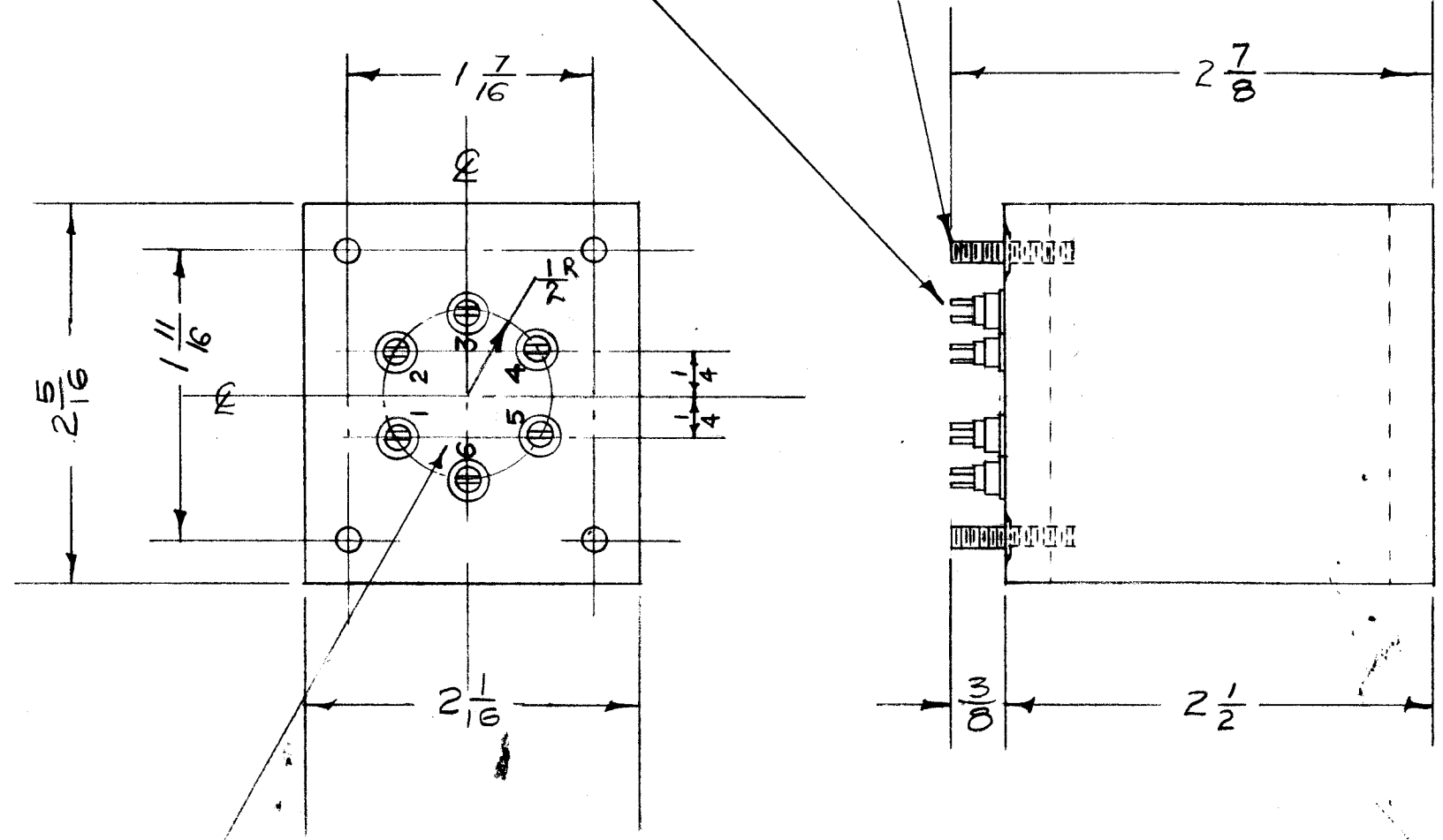

NOTICE TO PERSONS RECEIVING THIS DRAWING

THE TECHNICAL MATERIEL CORPORATION claims proprietary right in the material disclosed hereon. This drawing is issued in confidence for engineering information only and may not be reproduced or used to manufacture anything shown hereon without permission from THE TECHNICAL MATERIEL CORPORATION to the user. This drawing is loaned for mutual assistance and is subject to recall at any time.

Property of:

THE TECHNICAL MATERIEL CORPORATION
MAMARONECK, NEW YORK

STAMP AS SHOWN WITH 1/8 METAL STAMP (GOTHIC)

DIM. FOR REF. ONLY

REF. HELDOR MFG CO. CAT. NO. 100-FB MOD. (MC-BX-100-BD)

ISSUE	ITEM	CHANGED FROM	DATE	CN. NO.	DRAFTS	CHECKER	ENG. APP.
F	1	DIM. CHG'D FROM 1/4 STUD TO 3/8, 2.012 X 2.240 TO 2 1/16 X 2 5/16 ACC. TO MIL-T-27A	11/3/58	6	16	JAC	WJC
E	1	FINISH WAS ELECTRO TIN	8/31/58	5	16	JAC	WJC
D	1	- NOS. DELETED	5/13/57	4	16	JAC	WJC
C	1	BX-114-1 WAS TF-134	11/4/54	3	16	JAC	WJC
B	1	STAMPING ADDED TO COVER	10/28/53	2	16	JAC	WJC
A	1	NF-101 WAS TF-135	10/9/53	1	16	JAC	WJC

TOLERANCES		SCALE: FULL	
ALL OTHERS	DEC. DIM. ± FRAC. DIM. ± ANGULAR DIM. ±	DRILL, PUNCH, COMMERCIAL STOCK SIZES AND MANUFACTURERS TOLERANCES ARE NOT INCLUDED.	

MODEL	PROJECT NO.	ASS'Y. NO.	DATE

REQ.	ITEM	PART NO.	DESCRIPTION	SYMBOL
		.019-.025	THE TECHNICAL MATERIEL CORP.	
		STOCK SIZE	MAMARONECK, NEW YORK	
		STEEL	CASE, TRANSFORMER	
		MATERIAL	WEIGHT PER PC.	
		TYPE & TEMPER	16 10-6-53	G.T.O. WJC
			DRAWN	ELEC. DES. APP. MECH. DES. APP.
		HEAT TREAT. SPEC.	JAC RB	G.T.O. WJC
			CHECKED	FINAL APPROVAL
		HOT-TINNED		
		FINISH & SPEC. NO.	BX-114	F