

REVISIONS							
E.M.N. NO.	DRAFT	CHKD	ZONE	LTR	DESCRIPTION	DATE	APPROVED
	GDL			X	EXP RELEASE		
	J.P.			Ø		5/20/75	

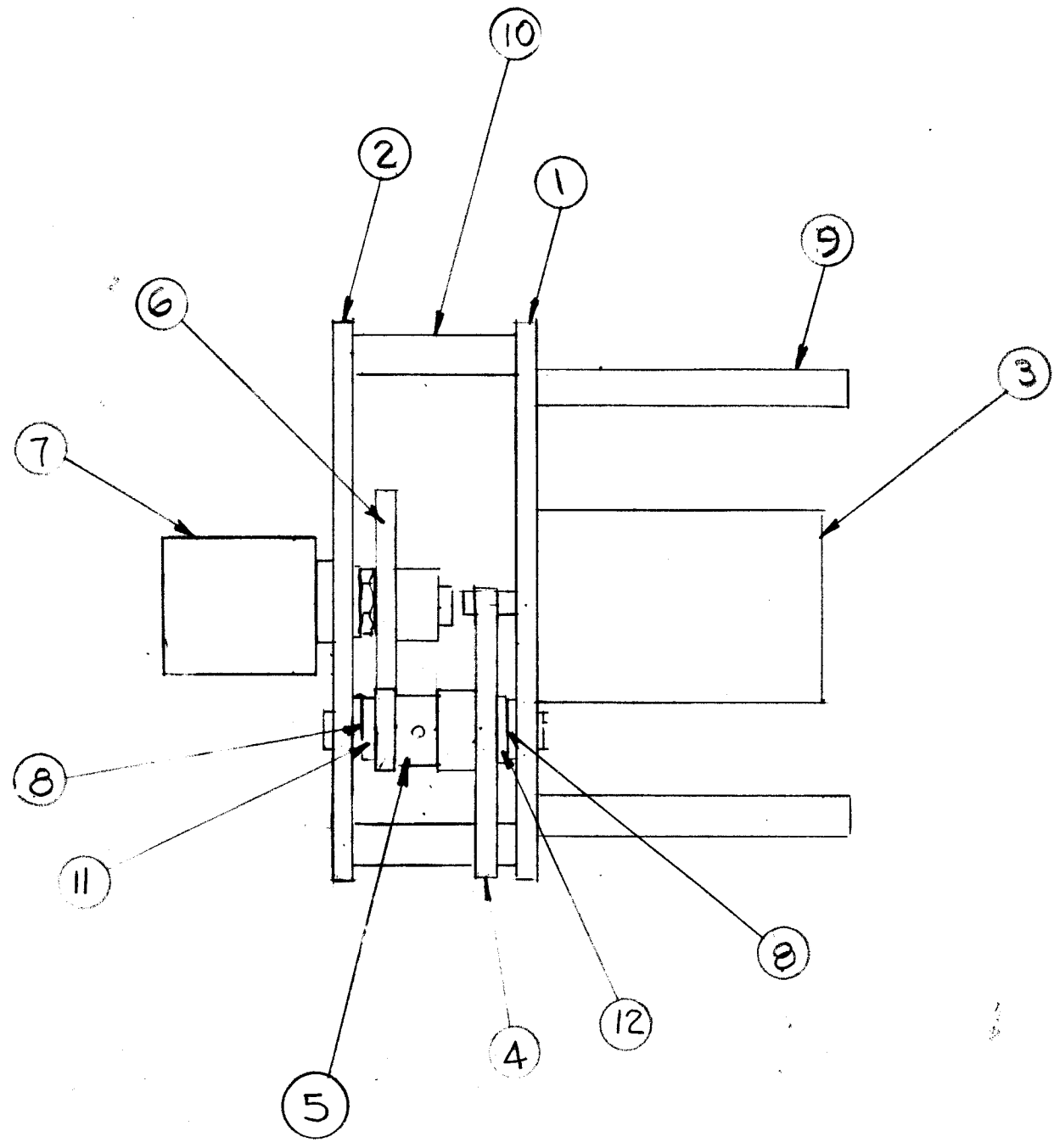

2	12	FW25LSS16	FLAT WASHER	
2	11	FW25LSS16	FLAT WASHER	
3	10	TE 0440BN87H	SPACER	
2	9	TE 0632AP200	SPACER	
2	8	BB 117-6	NYLON PANEL BEARING	
1	7	RV 117-2-102	RESISTANCE VARIABLE	
1	6	GR 205-40	GEAR, SPUR HUB	
1	5	A 5603	GEAR ASSY	
1	4	GR 242	PIN-TYE GEAR	
1	3	MO 130-2	MOTOR	
1	2	MS 6563	PLATE MTG MOTOR	
1	1	MS 6562	PLATE MTG GEAR	
REQ'D	ITEM	PART NUMBER	DESCRIPTION	SYM.

LIST OF MATERIAL

1	GP2 110	(KIT 404)
QTY / UNIT	MODEL USED ON	ASS'Y NO.
APPLICATION		
CODE		

**NOTICE TO PERSONS RECEIVING THIS DRAWING**  
 THE TECHNICAL MATERIEL CORPORATION claims proprietary right in the material disclosed hereon. This drawing is issued in confidence for engineering information only and may not be reproduced or used to manufacture anything shown hereon without permission from THE TECHNICAL MATERIEL CORPORATION to the user. This drawing is loaned for mutual assistance and is subject to recall at any time.

UNLESS OTHERWISE SPECIFIED DIMENSIONS ARE IN INCHES AND INCLUDE CHEMICALLY APPLIED OR PLATED FINISHES		FINAL APPROVAL <i>[Signature]</i>	DATE 5/17/75
DECIMALS .X ± .05 .XX ± .01 .XXX ± .005	FRACTIONS 1/64 ANGLES 0° - 30'	MECH. DES.	DATE
MATERIAL		ELECT. DES.	DATE
FINISH		CHECKED <i>[Signature]</i>	DATE
		DRAWN <i>[Signature]</i>	DATE

THE TECHNICAL MATERIEL CORP. MAMARONECK, NEW YORK			
ASSEMBLY, TUNING GEAR			
SIZE B	CODE IDENT. NO. 82679	DWG NO. A5623	ISSUE Ø
SCALE 1:1	SHEET		OF