

TMC P/N	AMT OF TURNS	ASSY NO
A4985-1	5 1/2	A4983-1
A4985-2	6 1/2	A4983-2

REVISIONS							
E.M.N. NO.	DRAFT	CHKD	ZONE	LTR	DESCRIPTION	DATE	APPROVED
				X1	A4985-3 NO LONG REQ.	1-7-74	
	G.E.			Ø	ORIGINAL RELEASE FOR PRODUCTION	1-25-77	*

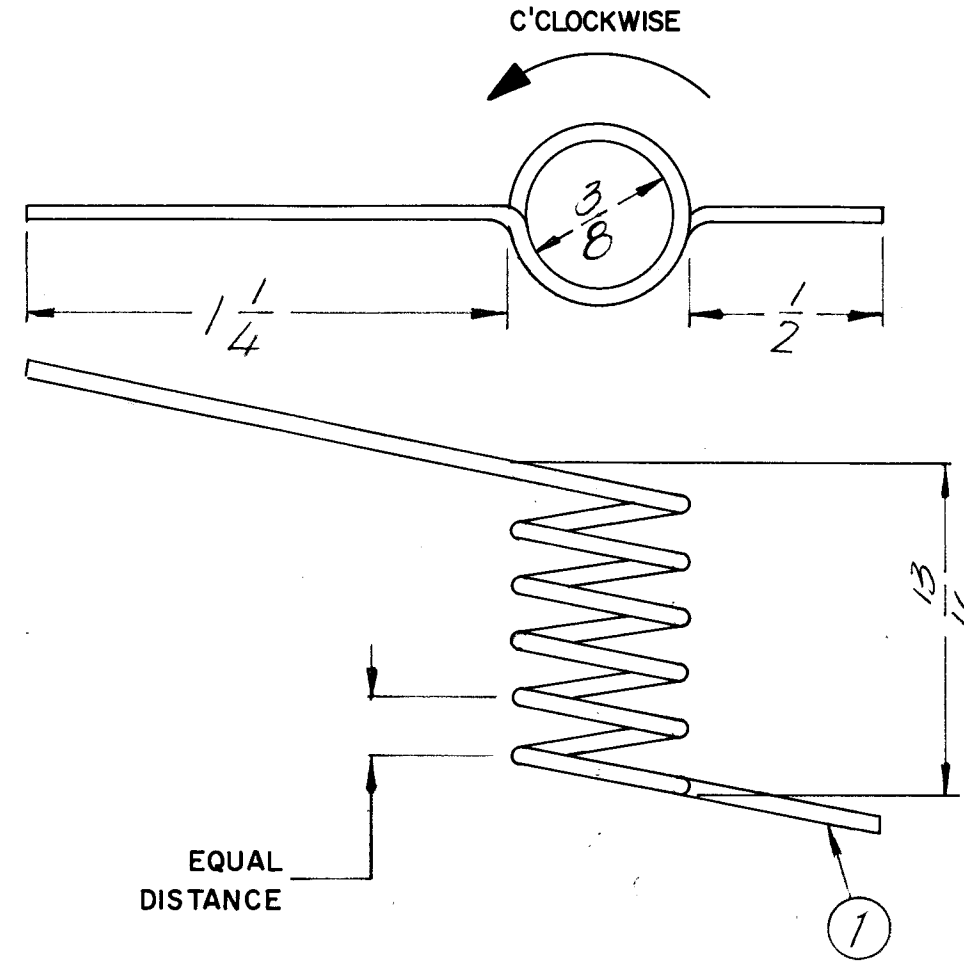

NOTE: COIL TO BE WOUND IN COUNTER CLOCKWISE DIRECTION TO DESIRED AMOUNT OF TURNS, KEEPING DISTANCE BETWEEN COILS EQUAL.

REF. CF143

QTY / UNIT	MODEL USED ON	ASS'Y NO.
	GPR110	CL484
APPLICATION		
	CODE	

NOTICE TO PERSONS RECEIVING THIS DRAWING
 THE TECHNICAL MATERIEL CORPORATION claims proprietary right in the material disclosed hereon. This drawing is issued in confidence for engineering information only and may not be reproduced or used to manufacture anything shown hereon without permission from THE TECHNICAL MATERIEL CORPORATION to the user. This drawing is loaned for mutual assistance and is subject to recall at any time.

UNLESS OTHERWISE SPECIFIED DIMENSIONS ARE IN INCHES AND INCLUDE CHEMICALLY APPLIED OR PLATED FINISHES		FINAL APPROVAL	DATE
DECIMALS	FRACTIONS	MECH. DES.	DATE
.X ± .05	TOLS. 1/64	ELECT. DES.	DATE
.XX ± .01	ANGLES	CHECKED	DATE
.XXX ± .005	0° - 30'	DRAWN	DATE
MATERIAL			
FINISH			

REQ'D	ITEM	PART NUMBER	DESCRIPTION	SYM.
X	1	WL100-5	WIRE ELEC.	

F.B. LIST OF MATERIAL

THE TECHNICAL MATERIEL CORP.
 MAMARONECK, NEW YORK

HFO COIL

SIZE	CODE IDENT. NO.	DWG NO.	ISSUE
B	82679	A4985	Ø
SCALE 2:1		SHEET	OF