

REVISIONS						
ZONE	LTR	DESCRIPTION	DATE	E.M.N.NO	DRAFT	CHKD APPD
	Ø	ORIGINAL RELEASE FOR PRODUCTION	11-13-72		ES	
	A	ADD Z1 SYMBOL, -+ TO C20	12-2-73	21017	GE	aka aka

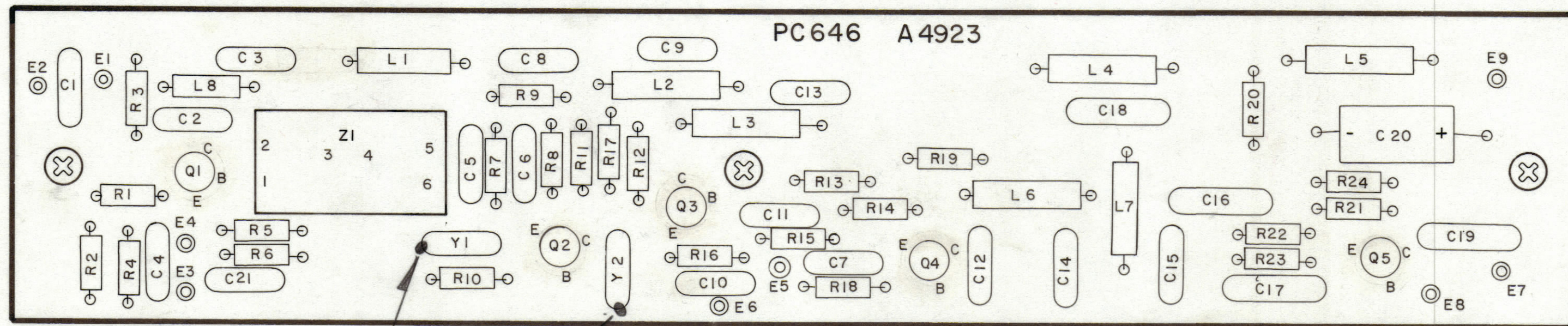

ASSEMBLY NOTES

1. TO MOUNT COMPONENTS, INSERT LEADS THROUGH PLATED THRU HOLES.
2. CAUTION WHEN APPLYING HEAT AND SOLDER TO LEAD AND FOIL.
3. CLEAN AND INSPECT AS PER SPEC. S676.
4. FOR ELECTRICAL COMPONENT PART NUMBERS REFER TO NPL A4923.
5. USE SYMBOL NUMBERS FOR ASSY. REF.

QTY. REQ.	ITEM	PART NO.	DESCRIPTION	SYMBOL
X	2	BS100	SOLDER TIN ALLOY	
1	1	PC646	PRINTED CIRCUIT BD.	

LIST OF MATERIAL

FINAL APPROVAL: *[Signature]* DATE: 11/9/72
 MECH. DES: *[Signature]* DATE: 11-9-72
 ELECT. DES. DATE: _____
 CHECKED DATE: _____
 DRAWN: *EVANGELIST* DATE: 11/10/72

THE TECHNICAL MATERIEL CORP.
 MAMARONECK, NEW YORK

ASSY. PRINTED CIRCUIT BD.
 THIRD MIXER

SIZE	CODE	IDENT. NO.	DWG. NO.	ISSUE
C	82679	A4923		A

SCALE 2:1 SHEET OF

QTY / UNIT	MODEL USED ON	ASSY NO.
1	RSU-1	
APPLICATION		
	CODE	

NOTICE TO PERSONS RECEIVING THIS DRAWING
 THE TECHNICAL MATERIEL CORPORATION claims proprietary right in the material disclosed hereon. This drawing is issued in confidence for engineering information only and may not be reproduced or used to manufacture anything shown hereon without permission from THE TECHNICAL MATERIEL CORPORATION to the user. This drawing is loaned for mutual assistance and is subject to recall at any time.

A 4923