

A-3238 0

THE CONTENTS OF THIS DRAWING ARE THE EXCLUSIVE PROPERTY OF THE TECHNICAL MATERIEL CORP. ITS UNAUTHORIZED USE OR REPRODUCTION IN WHOLE OR IN PART IS STRICTLY FORBIDDEN.

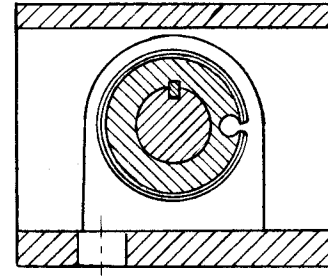
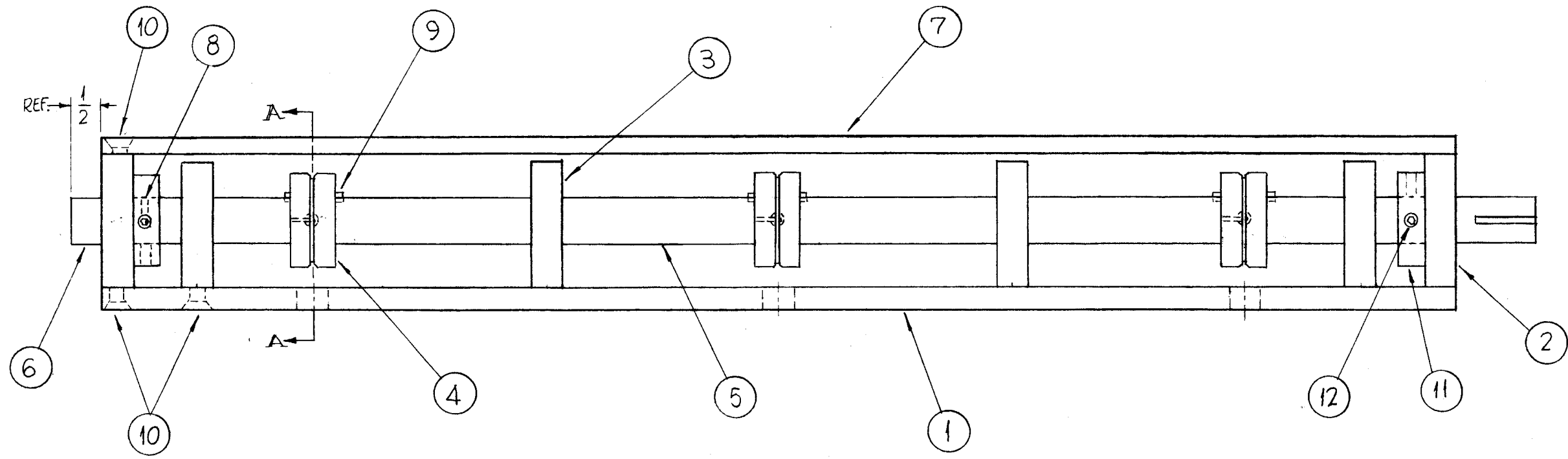

SECTION-A-A

4	12	SLHC2520SS6	SETSCREW
2	11	MC-126-B2	COUPLING, SHAFT, RIGID
16	10	SC-156-2520SS9	SCREW, SOCKET HEAD
3	9	KY-102-2-1.000SS	KEY, SQUARE
1	8	PN-59-094-12	PIN, SPRING
1	7	PM-940	PLATE, SUPPORT, TOP
1	6	PM-943	COUPLING, GEAR ASS'Y
1	5	PM-949	SHAFT PULLEY MTG.
3	4	PM-956	PULLEY, CAP. DRIVE
4	3	PM-936	SUPPORT, SHAFT GUIDE
2	2	PM-935	PLATE, SIDE
1	1	PM-939	PLATE, SUPPORT, BOTTOM

REQ.	ITEM	PART NO.	F. BUDETTI	DESCRIPTION	SYMBOL
STOCK SIZE			THE TECHNICAL MATERIEL CORP. MAMARONECK, NEW YORK		
MATERIAL			PULLEY BOX ASS'Y		
TYPE & TEMPER		HEAT TREAT. SPEC.	DRAWN	CHECKED	FINAL APPROVAL
FINISH & SPEC. NO.		ELEC. DES. APP.	MECH. DES. APP.	A-3238 0	

0	ORIGINAL RELEASE FOR PRODUCTION	3-3-64				
SYM	DESCRIPTION	DATE	CH. NO.	DRAFTS	CHECKER	ENG. APP.
UNLESS OTHERWISE SPECIFIED:		SCALE: 1/2"=1"				
DIMENSIONS ARE IN INCHES		MAXIMUM ALLOWABLE TOLERANCES HAVE BEEN DETERMINED AND ANY DEVIATIONS WILL BE CAUSE FOR REJECTION.				
TOLERANCES ON FRACTIONS ± 1/64		REMOVE ALL BURRS AND SHARP EDGES				
DECIMALS ± .005						
ANGLES ± 1/2°						

REQ. PER UNIT	MODEL	SECTION	ASS'Y. NO.	DATE
1	GPT-200K	AX-395	A-3186	2-10-64
1	GPT-200K	AX-395	A-3185	10-17-63