

THE CONTENTS OF THIS DRAWING ARE THE EXCLUSIVE PROPERTY OF THE TECHNICAL MATERIEL CORP. ITS UNAUTHORIZED USE OR REPRODUCTION IN WHOLE OR IN PART IS STRICTLY FORBIDDEN.

A-2354

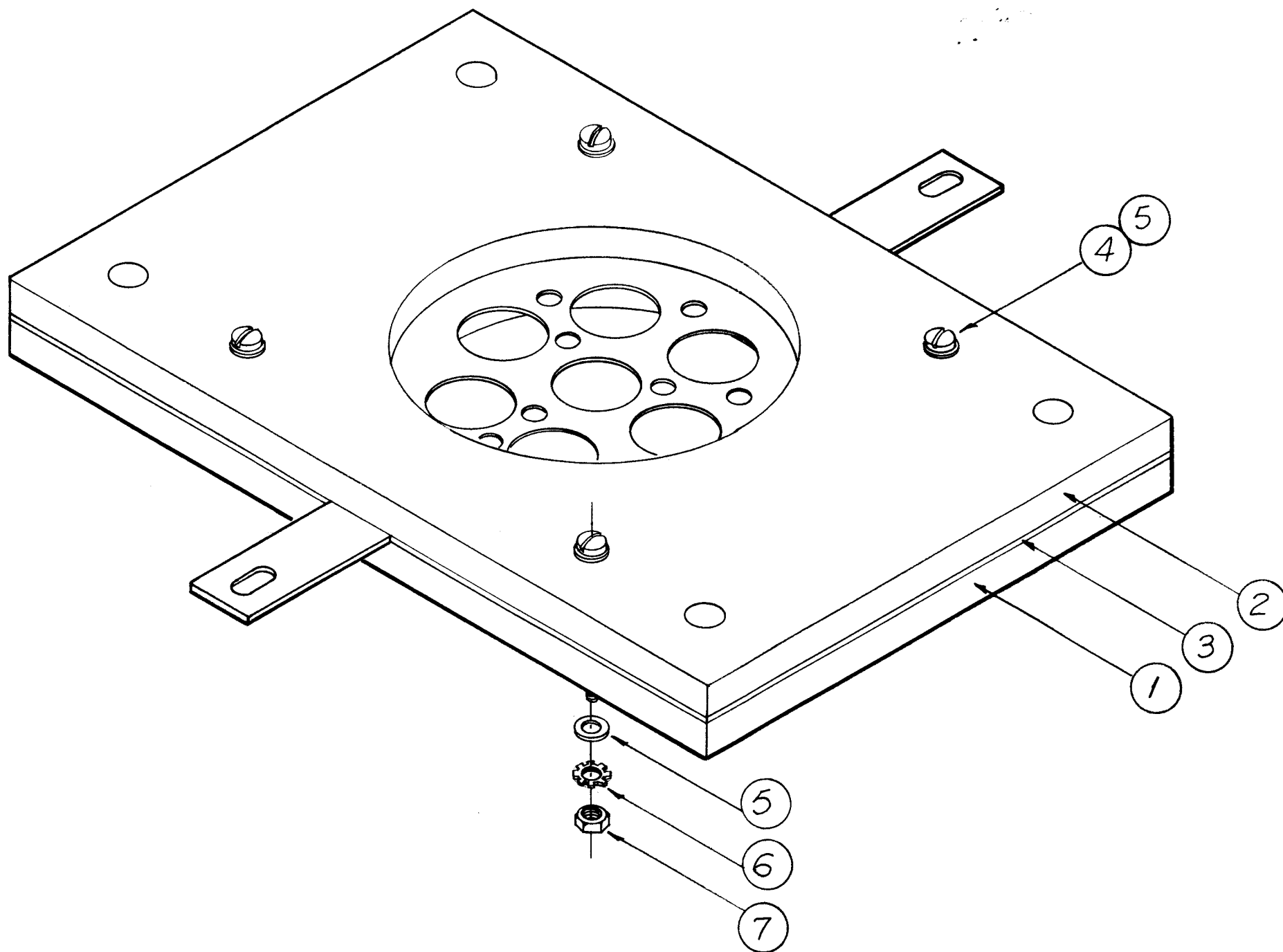

4	7	NTL1032BN12	NUT, HEX.
4	6	LWE10MRN	LOCKWASHER, EXT.
8	5	FW10HBN	WASHER, FLAT
4	4	SCBS1032BN24	SCREW, MACHINE
1	3	MS-2854	PLATE, CONTACT, TOP, RIGHT
1	2	PX-364-2	PLATE, PRESSURE, INSIDE, TOP
1	1	PX-363-1	PLATE, PRESSURE, OUTSIDE, TOP

REQ.	ITEM	PART NO.	DESCRIPTION	SYMBOL
			THE TECHNICAL MATERIEL CORP.	
			MAMARONECK, NEW YORK	
			PRESSURE PLATE ASS'Y., TOP, RIGHT	
			MATERIAL	
			D. J. Man	RUZZO
			OKS	MC
			FINAL APPROVAL	
			A-2354	

SYM	DESCRIPTION	DATE	CH. NO.	DRAFTS	CHECKER	ENG. APP.
	UNLESS OTHERWISE SPECIFIED:					
	DIMENSIONS ARE IN INCHES					
	TOLERANCES ON FRACTIONS ± 1/64					
	DECIMALS ± .005					
	ANGLES ± 1/2°					
	SCALE: $\frac{1}{2}'' = 1''$					
	MAXIMUM ALLOWABLE TOLERANCES HAVE BEEN DETERMINED AND ANY DEVIATIONS WILL BE CAUSE FOR REJECTION.					
	REMOVE ALL BURRS AND SHARP EDGES					

1	TER-5K-50			1-29-62
REQ. PER UNIT	MODEL	SECTION	ASS'Y. NO.	DATE
USED ON				