

THE CONTENTS OF THIS DRAWING ARE THE EXCLUSIVE PROPERTY OF THE TECHNICAL MATERIEL CORP. ITS UNAUTHORIZED USE OR REPRODUCTION IN WHOLE OR IN PART IS STRICTLY FORBIDDEN.

REQ. PER UNIT

1

MODEL

CAB-1

USED ON

DATE

1-15-62

A-2282

A

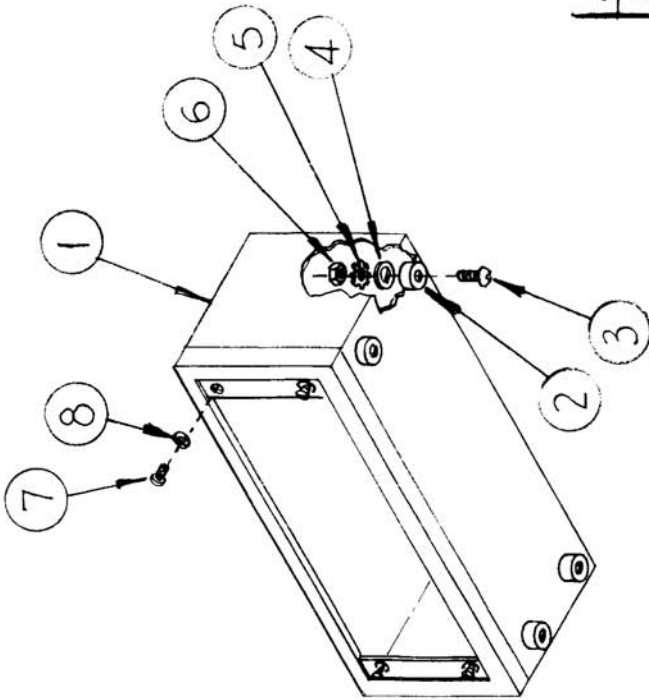

NOTE ~ Items 7 & 8 Supplied as Loose Items.

4	8	WA-101-5	WASHER, FIBRE
4	7	SCBP1032BN8	SCREW, MACHINE
4	6	NTH1032BN10	NUT, HEX.
4	5	LWE10MRN	LOCKWASHER, EXT.
4	4	FW10LHBN	WASHER, FLAT
4	3	SCBP1032BN20	SCREW, MACHINE
4	2	PX-277	CASE MOUNTS
1	1	MS-1167	CABINET, ELECTRICAL, EQUIP.

REQ. ITEM	PART NO.	DESCRIPTION	SYMBOL
STOCK SIZE			
MATERIAL			
THE TECHNICAL MATERIEL CORP. MAMARONECK, NEW YORK			
FINAL ASSEMBLY, CAB-1			
TYPE & TEMPER	HEAT TREAT. SPEC.	DRAWN	CHECKED
		D.P. [Signature]	R. [Signature]
FINISH & SPEC. NO.		ELEC. DES. APP.	MECH. DES. APP.
			A-2282
			A

SYM	DESCRIPTION	DATE	CH. NO.	DRAFTS	CHECKER	ENG. APP.
A	ITEM 7 WAS SCBP0832BN8 ITEM 8 WAS WA-101-11	5-25-62	6698	V.R.R.	[Signature]	[Signature]

SCALE:

UNLESS OTHERWISE SPECIFIED:
DIMENSIONS ARE IN INCHES
TOLERANCES ON
FRAC. ± 1/64 DEC. ± .005 ANGLES ± 1/2°

MAXIMUM ALLOWABLE TOLERANCES HAVE BEEN DETERMINED AND ANY DEVIATIONS WILL BE CAUSE FOR REJECTION.
REMOVE ALL BURRS AND SHARP EDGES