

A-2118 B

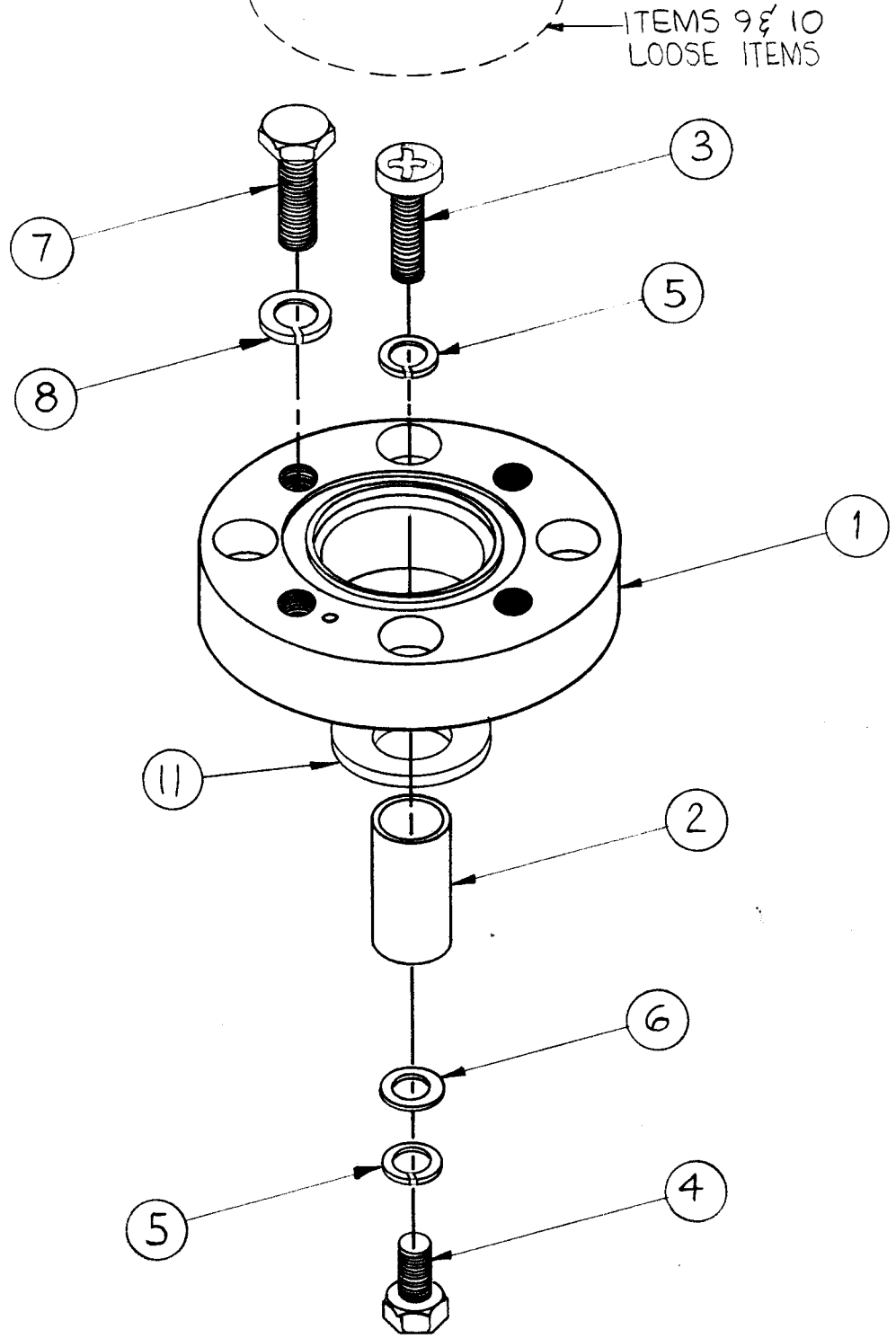

TMC PART NO.	ITEM 9 LOOSE ITEM CONNECTION	ITEM 10 LOOSE ITEM CONNECTION
AX-272-1	NONE	NONE
AX-272-2	PO-171-50	NONE
AX-272-3	PO-326	NONE

1	11	GA-102	GASKET
1	10	SEE CHART	
1	9	SEE CHART	
4	8	LWS31MSS	LOCKWASHER, SPLIT
4	7	SCHH3118SS16	SCREW, MACHINE
1	6	FW25HSS	WASHER, FLAT
5	5	LWS25MSS	LOCKWASHER, SPLIT
1	4	SCHH2520SS10	SCREW, MACHINE
4	3	SCR2520SS16	SCREW, MACHINE
1	2	PM-710-1	ADAPTOR, CONTACT, 50Ω
1	1	PM-708	PLATE, ADAPTOR, 15/8 E.I.A.

SYM	DESCRIPTION	DATE	CH. NO.	DRAFTS	CHECKER	ENG. APP.
C	ADDE AX272-3; PO-326; NONE	4-15-71	20312	RF	W	W.P.S.
B	ITEM 8 WAS LWS31MRN, 7 WAS SCHH3118BN16 ITEM 6 WAS FW25HBN, 5 WAS LWS25MRN	8-17-62	7076	GS	Jde	LB
A	ITEM 2 WAS PM-710; ITEMS 9(10)(11) ADDED ITEM 3 WAS SCHH2520BN16	5-24-62	5753	JF	Jde	DDP

UNLESS OTHERWISE SPECIFIED:
 DIMENSIONS ARE IN INCHES
 TOLERANCES ON FRACTIONS ± 1/64 DECIMALS ± .005 ANGLES ± 1/2°

SCALE: DO NOT SCALE
 MAXIMUM ALLOWABLE TOLERANCES HAVE BEEN DETERMINED AND ANY DEVIATIONS WILL BE CAUSE FOR REJECTION.
 REMOVE ALL BURRS AND SHARP EDGES

REQ. PER UNIT	MODEL	SECTION	ASS'Y. NO.	DATE
				8-29-61

REQ.	ITEM	PART NO.	DESCRIPTION	SYMBOL
THE TECHNICAL MATERIEL CORP. MAMARONECK, NEW YORK AX-272 ASS'Y. (FLANGE CONTACT ASS'Y.) 50Ω				
TYPE & TEMPER		HEAT TREAT. SPEC.	DRAWN	CHECKER
			W.A.F.	Jde
			AL	LB
FINISH & SPEC. NO.		ELEC. DES. APP.	MECH. DES. APP.	
				A-2118