

A-2113 B

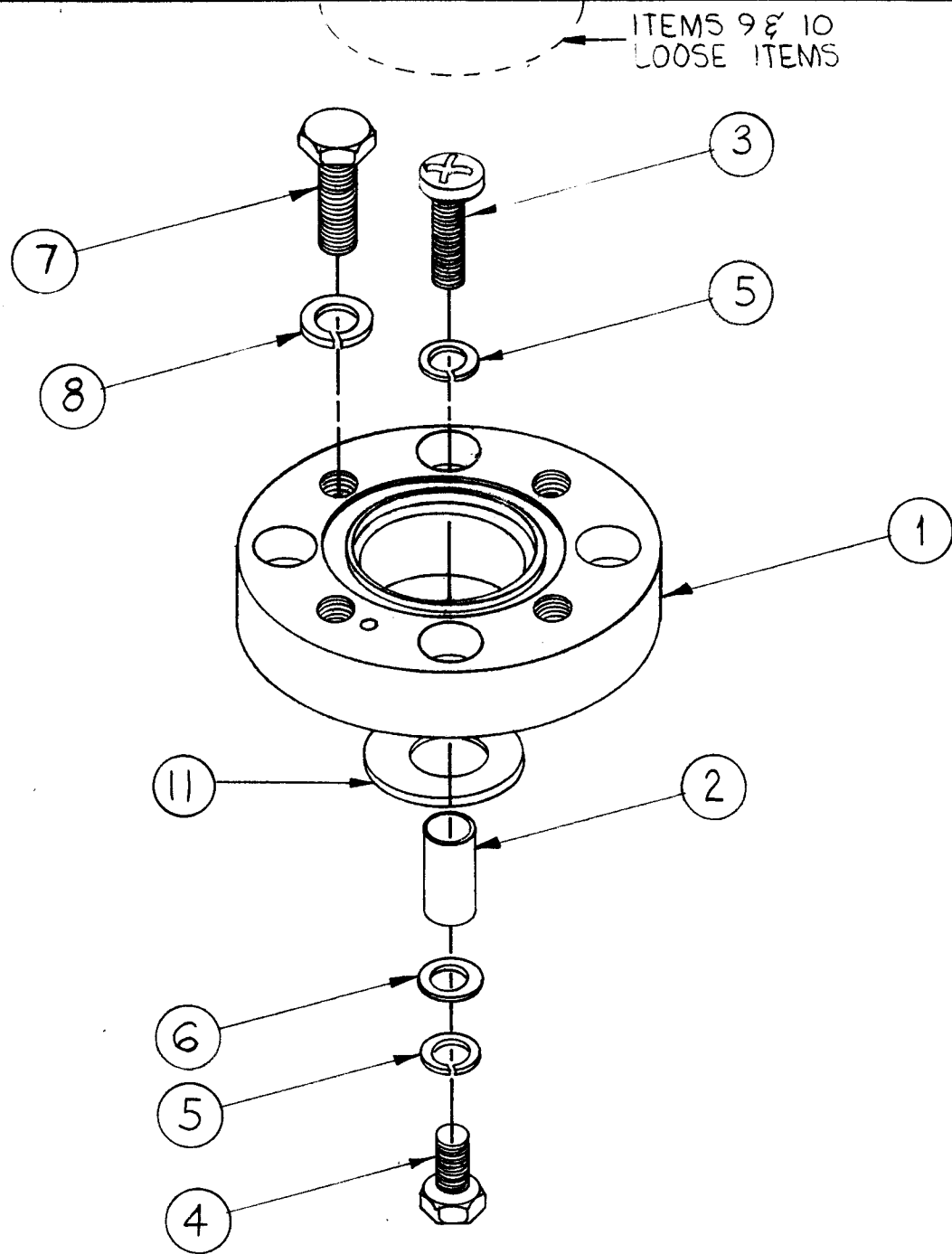

TMC PART NO.	ITEM 9 LOOSE ITEM CONNECTION	ITEM 10 LOOSE ITEM CONNECTION
AX-271-1	NONE	NONE
AX-271-2	PO-171-70	NONE

1	11	GA-102	GASKET
1	10	SEE CHART	
1	9	SEE CHART	
4	8	LWS31MSS	LOCKWASHER, SPLIT
4	7	SCHH3118SS16	SCREW, MACHINE
1	6	FW25HSS	WASHER, FLAT
5	5	LWS25MSS	LOCKWASHER, SPLIT
1	4	SCHH2520SS10	SCREW, MACHINE
4	3	SCRD2520SS16	SCREW, MACHINE
1	2	PM-707-1	ADAPTOR, CONTACT 70Ω
1	1	PM-708	PLATE, ADAPTOR 1 5/8 E.I.A.

B	ITEM 4 WAS SCHH2520BN16, 3 WAS SCR2520BN16	8-17-62	7076	G.S.	<i>[Signature]</i>	
A	ITEM 2 WAS PM-707-1; ITEMS 9, 10, 11 ADDED ITEM 3 WAS SCHH2520BN16	5-24-62	5753	EE	<i>[Signature]</i>	
SYM	DESCRIPTION	DATE	CH. NO.	DRAFTS	CHECKER	ENG. APP.

UNLESS OTHERWISE SPECIFIED:
 DIMENSIONS ARE IN INCHES
 TOLERANCES ON FRACTIONS ± 1/64 DECIMALS ± .005 ANGLES ± 1/2°

SCALE: DO NOT SCALE
 MAXIMUM ALLOWABLE TOLERANCES HAVE BEEN DETERMINED AND ANY DEVIATIONS WILL BE CAUSE FOR REJECTION.
 REMOVE ALL BURRS AND SHARP EDGES

REQ. PER UNIT	MODEL	SECTION	ASS'Y. NO.	DATE
	AX-271			8-21-61
USED ON				

REQ.	ITEM	PART NO.	DESCRIPTION	SYMBOL
THE TECHNICAL MATERIEL CORP. MAMARONECK, NEW YORK AX-271 ASS'Y. (FLANGE CONTACT ASS'Y.) 70Ω				
TYPE & TEMPER		HEAT TREAT. SPEC.	DRAWN	CHECKER
			<i>[Signature]</i>	<i>[Signature]</i>
FINISH & SPEC. NO.			ELEC. DES. APP.	MECH. DES. APP.
			A-2113	B