

IF IT IS FOUND DESIRABLE TO CHANGE ANY TOLERANCE OR OTHER DETAIL SPECIFIED ON THIS DRAWING NOTIFY THE PURCHASER PROMPTLY.

RELEASED

MAXIMUM ALLOWABLE TOLERANCES HAVE BEEN DETERMINED AND DEVIATIONS WILL BE CAUSE FOR REJECTION. REMOVE ALL BURRS AND SHARP EDGES

A-287 A

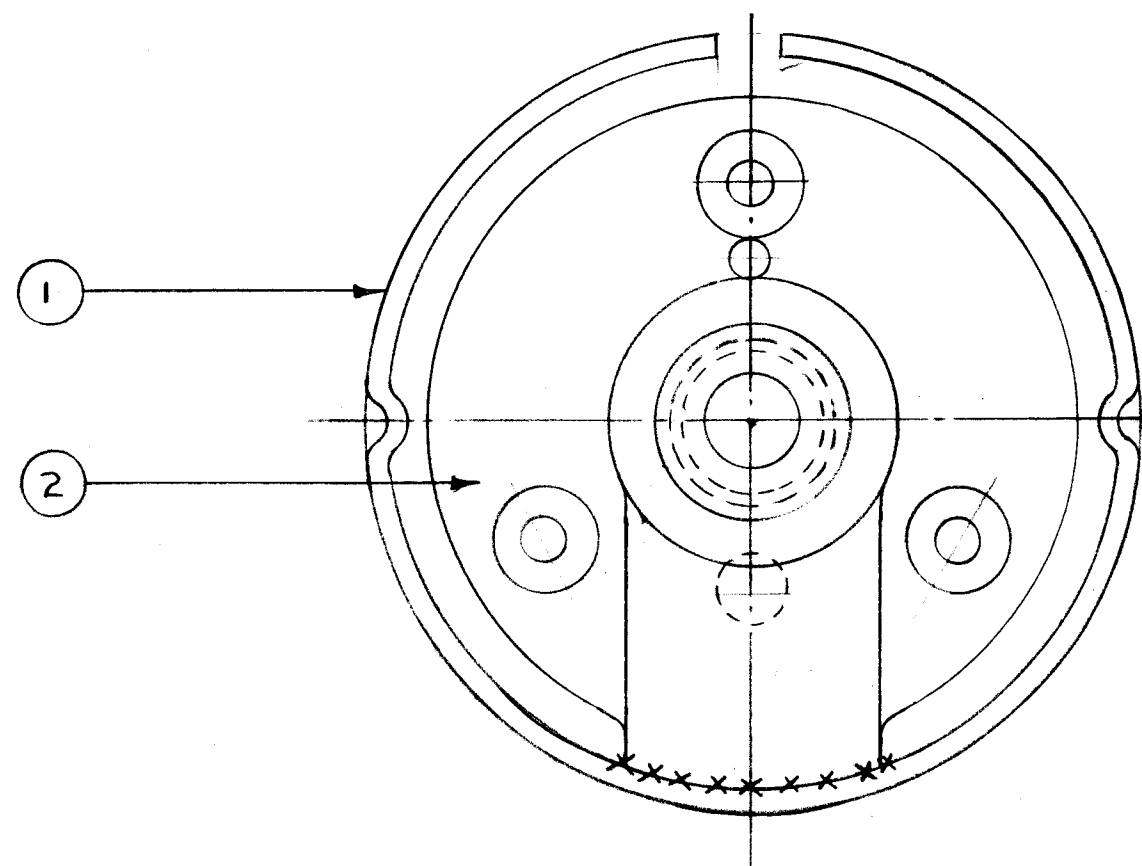
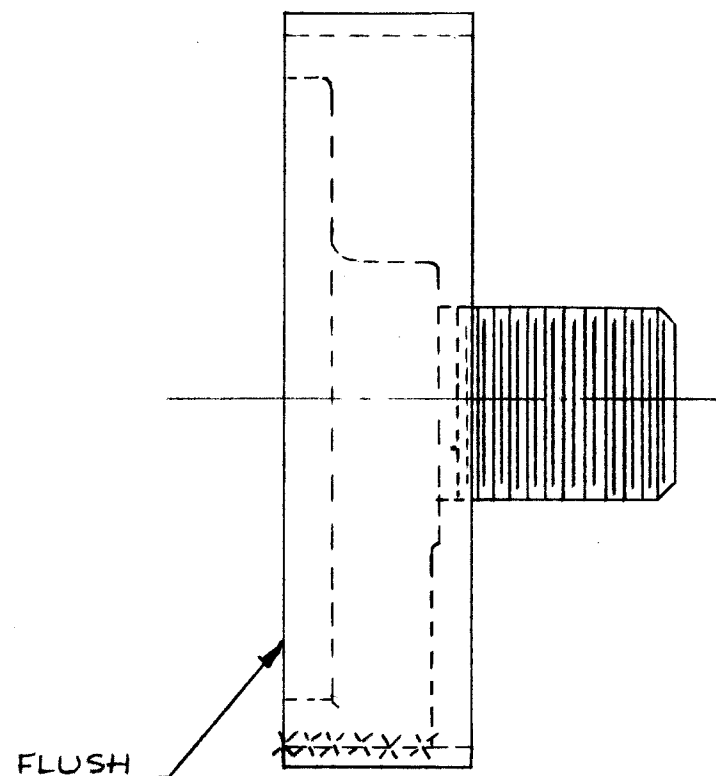

"X" DENOTES BRAZE

NOTE:
1. S-404 YELLOW IRIDITE
2. S-135+ (BRIGHT NICKEL PLATE)

1	2	CS-111	CLUTCH SUPPORT	
1	1	PM-177	CLUTCH RING	
REQ.	ITEM	PART NO.	DESCRIPTION	SYMBOL
ff			THE TECHNICAL MATERIEL CORP.	
STOCK SIZE			MAMARONECK. NEW YORK	
ff		ff	CLUTCH ASS'Y.	
MATERIAL		WEIGHT PER PC.		
ff				
TYPE & TEMPER			16 12-4-52	
ff			DRAWN	ELEC. DES. APP. MECH. DES. APP.
HEAT TREAT. SPEC.			12-15-52	CHECKED
SEE NOTE			FINAL APPROVAL	
FINISH & SPEC. NO.			A-287 A	

A	1	S-404 WAS S-101	12-10-59	1001	AB	EMN	
ISSUE	ITEM	CHANGED FROM	DATE	CN. NO.	DRAFTS	CHECKER	ENG. APP.
TOLERANCES		SCALE: TWICE					
ALL OTHERS	DEC. DIM. ± FRAC. DIM. ± ANGULAR DIM. ±	DRILL, PUNCH, COMMERCIAL STOCK SIZES AND MANUFACTURERS TOLERANCES ARE NOT INCLUDED.					

R-12	168	A-289	12-4-52
R-10	168	A-289	12-4-52
R-8	168	A-289	12-4-52
MODEL	PROJECT NO.	ASS'Y. NO.	DATE

USED ON