

IF IT IS FOUND DESIRABLE TO CHANGE ANY TOLERANCE OR OTHER DETAIL SPECIFIED ON THIS DRAWING NOTIFY THE PURCHASER PROMPTLY.

MAXIMUM ALLOWABLE TOLERANCES HAVE BEEN DETERMINED AND DEVIATIONS WILL BE CAUSE FOR REJECTION. REMOVE ALL BURRS AND SHARP EDGES

A-217 B

FORCE FIT PN-100 AND GRIND SMOOTH.

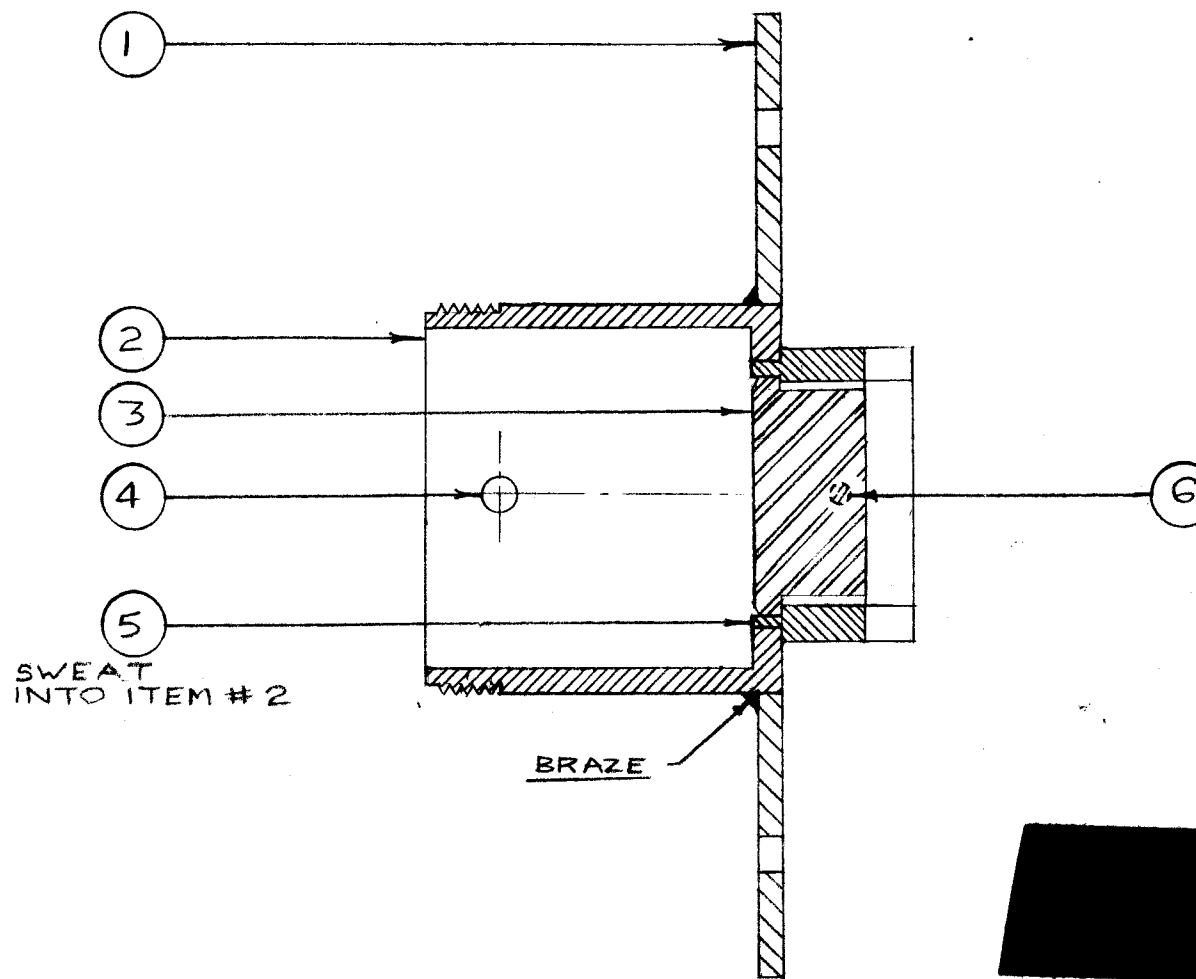
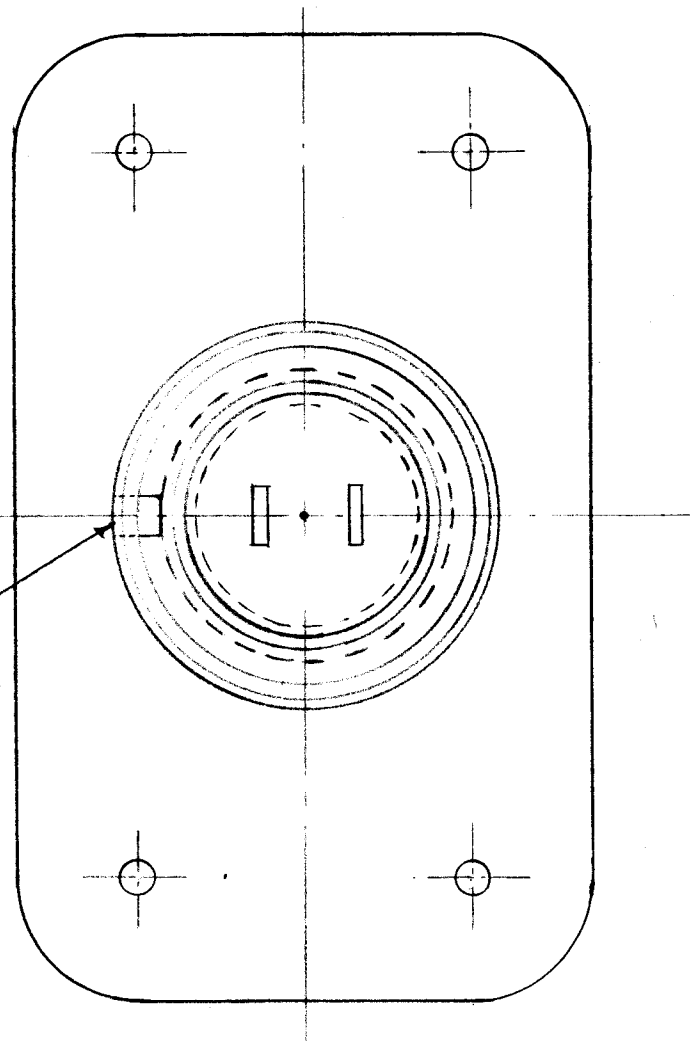

NOTE:

- FINISH SEQUENCE AFTER ASS'Y. EXCLUDE (3) AND (6)
 1. S-105 (CADMIUM PLATE) ALL OVER.
 2. S-106 (BRIGHT IRIDITE) ALL OVER.
 3. S-151 (GREY WRINKLE PAINT) OUTSIDE SURFACES ONLY

2	6	AN565D6-4	SET SCREW	
1	5	PM-143	PLUG RING	
1	4	PN-100	GUIDE PIN	
1	3	JJ-122-1	RECEPTACLE	
1	2	SM-118	BASE RING	
1	1	MS-161	FLANGE	
REQ.	ITEM	PART NO.	DESCRIPTION	SYMBOL
//			THE TECHNICAL MATERIEL CORP. MAMARONECK. NEW YORK	
//			BASE FLANGE, ASSEMBLY	
//			DRAWN	MECH. DES. APP.
//			CHECKED	FINAL APPROVAL
//			A-217 B	
//			SEE NOTE	
//			FINISH & SPEC. NO.	

B	1	ITEM (3) WAS JJ-122	3-26-63	8656			
A	1	ITEM 3, POS. CHANGED	3/30/59	1			
ISSUE	ITEM	CHANGED FROM	DATE	CN. NO.	DRAFTS	CHECKER	ENG. APP.

TOLERANCES		SCALE:	
ALL OTHERS	DEC. DIM. ± FRAC. DIM. ± ANGULAR DIM. ±	DRILL, PUNCH, COMMERCIAL STOCK SIZES AND MANUFACTURERS TOLERANCES ARE NOT INCLUDED.	

TWR-115	151	A-237	9-25-52
MODEL	PROJECT NO.	ASS'Y. NO.	DATE
USED ON			